

CONSTRUCTION SPECIFICATIONS

SOUTH SAN JOAQUIN IRRIGATION DISTRICT
MAIN OFFICE PAVEMENT IMPROVEMENT PROJECT
PHASE 2

SAN JOAQUIN COUNTY, CALIFORNIA



SOUTH SAN JOAQUIN IRRIGATION DISTRICT
11011 E. HIGHWAY 120
MANTECA, CALIFORNIA 95336-9750
PHONE: (209) 249-4619

MAY 12, 2026

TABLE OF CONTENTS

**South San Joaquin Irrigation District
Main Office Pavement Improvement Project Phase 2**

BIDDING REQUIREMENTS

00101 Invitation to Bid and Notice to Contractors 4
00102 Instructions to Bidders 6

BID FORMS

00201 Bid Forms 10
00202 Bid Bond 17

CONTRACT DOCUMENTS

00301 Contract 19
00302 Faithful Performance Bond 31
00303 Payment Bond 33
00304 Worker's Compensation Insurance Certificate 35
00305 Contractor Safety Agreement 36

CONDITIONS OF THE CONTRACT

00401 General Conditions
 Section 1 – General 37
 Section 2 - Award and Execution of Contract 39
 Section 3 – Scope of Work 41
 Section 4 – Control of Work 42
 Section 5 – Control of Materials 45
 Section 6 - Legal Relations and Responsibilities to the Public 47
 Section 7 - Prosecution and Progress 53
 Section 8 - Measurement and Payment 55
00402 Special Provisions 62

GENERAL & SPECIFIC REQUIREMENTS

00501 General Construction Notes 67
00502 Summary of Work and Special Considerations 68

APPENDICES

Appendix A – Contract Plan Set

ENGINEER'S SIGNATURE PAGE

These construction plans and specifications for the

Main Office Pavement Improvement Project Phase 2
Project No. SSJID-26003

Have been prepared by, or under the direct supervision of, the following Registered Engineer:



Edgar Torres, P.E.
RCE: 94930
South San Joaquin Irrigation District
11011 E. Highway 120
Manteca, California 95336-9750
Phone: (209) 249-4600

**DOCUMENT 00101
INVITATION TO BID AND
NOTICE TO CONTRACTORS**

Sealed bid proposals will be received by the South San Joaquin Irrigation District for:

**Main Office Pavement Improvement Project Phase 2
San Joaquin County, California
Project No. SSJID-26003**

Bids are to be received at the **South San Joaquin Irrigation District Office, 11011 E. Highway 120, Manteca, California** until **2:00 p.m. on Wednesday, June 17th, 2026**, at which time the bids will be publicly opened and read to perform the work as follows:

Full-depth removal and replacement of approximately 19,315 square feet of asphalt concrete pavement, including subgrade preparation, compaction, placement of aggregate base, and placement of 3/4-inch Type A Hot Mix Asphalt (HMA). Removed materials shall be stockpiled at a designated on-site location. Additional work includes removal and replacement of striping and wheel stops; removal and replacement of approximately 335 square feet of 8-inch-thick reinforced concrete; removal and replacement of approximately 395 square feet of concrete valley gutter; application of asphalt pavement coating to approximately 2,975 square yards of existing pavement; Installation of joint trench conduit including pull boxes; and removal and replacement of approximately 128 linear feet of 6-inch storm drain pipe and 142 linear feet of 12-inch storm drain pipe. Work also includes temporary access, traffic control, coordination to maintain District operations, and implementation of water pollution control measures. The Contractor shall coordinate all work with District staff to maintain access and minimize disruption to District operations. The Engineer's Estimate for the contract work ("Work") is **\$309,000**.

The Work identified here is not meant to be an exhaustive or inclusive list but is intended to illustrate broadly the work required for completion of this Project.

It is expected that all Work, with the exception of asphalt pavement coating, will be completed within **30** calendar days from issuance of the Notice to Proceed. Asphalt pavement coating shall be completed within **75** calendar days from issuance of the Notice to Proceed. A Notice to Proceed is anticipated to be issued on **July 15, 2026**.

A MANDATORY pre-bid meeting is scheduled for Wednesday, June 3rd, 2026 at 10:00 a.m., at the District Office at 11011 E. Highway 120, Manteca. Prospective bidders are hereby notified that the Project site is located on private property and access thereto is limited to the meeting time scheduled and as accompanied by a representative of the District. Those wishing to attend this meeting should contact the District at **(209) 249-4619** to confirm attendance, and meeting date and time.

NO CONTRACTOR OR SUBCONTRACTOR MAY BE LISTED ON A BID PROPOSAL FOR A PUBLIC WORKS PROJECT (SUBMITTED ON OR AFTER MARCH 1, 2015) UNLESS REGISTERED WITH THE DEPARTMENT OF INDUSTRIAL RELATIONS ("DIR") PURSUANT TO LABOR CODE SECTION 1725.5. To register log on to the DIR website.
<https://efiling.dir.ca.gov/PWCR/ActionServlet?action=displayPWCRRegistrationForm>

THIS PROJECT IS SUBJECT TO COMPLIANCE MONITORING AND ENFORCEMENT BY THE DEPARTMENT OF INDUSTRIAL RELATIONS.

Bids must be accompanied by bidder's security in the amount to at least ten percent (10%) of the bid amount. Companies supplying sureties or bonds shall be admitted to supply such instruments within the State of California, shall be listed by the Office of the Insurance Commissioner, shall have a minimum **A.M. Best rating of "A" or better**, and have a demonstrated ability to meet their ongoing obligations to policyholders.

All Bids are to be compared on the basis of the Engineer's estimate of the quantities of work to be done. South San Joaquin Irrigation District reserves the right to reject any and all Bids. Bid award will be made on the basis of a single schedule of the base bid. The award, if made, will be to the lowest single responsive and responsible Bidder.

Bids submitted to the District by Contractors who are not licensed in accordance with the provisions of Chapter 9, Division III of the Business and Professions Code, State of California, shall be considered non-responsive and shall be rejected by the District. Prospective Bidders shall be skilled, regularly engaged and licensed in the general class or type of work specified and **possesses a valid California Class "A" Contractor's License.**

Electronic copies of the Plans, Specifications and Bid Forms may be obtained by contacting Dawn Driesen, at (209) 249-4619. Requesters will be placed on the "Plan Holder's List."

Technical, construction, and project-specific inquiries and questions should be directed to:
Edgar Torres, P.E., Associate Civil Engineer, Office: (209) 249-4647, Cell: (209)397-4579,
Email:edgar.torres@ssjid.gov.

The envelope enclosing the Bid shall be sealed and addressed to the **South San Joaquin Irrigation District** and mailed or hand delivered/delivered by courier to **11011 East Highway 120, Manteca, California 95336**. The envelope shall be plainly marked in the upper left-hand corner with the name and address of the bidder and shall bear the words "**Bid for**", followed by "**PROJECT NO. SSJID-26003 MAIN OFFICE PAVEMENT IMPROVEMENT PROJECT PHASE 2** " and the date and hour for opening of bids. The certified or cashier's check, money order, or bidder's bond, where applicable, shall be made payable to **South San Joaquin Irrigation District**. The bid security shall be enclosed in the same envelope with the Bid.

END OF DOCUMENT 00101

**DOCUMENT 00102
INSTRUCTIONS TO BIDDERS**

1.01 CONTENTS OF BID FORMS

Prospective Bidders will be furnished with Bid Forms, which will include a schedule of items for which prices are asked, showing the approximate estimate of the various quantities and kinds of work to be performed or materials to be furnished.

1.02 APPROXIMATE ESTIMATE OF QUANTITIES

The quantities given in the bid and contract are on a lump sum basis, being given as a basis for the comparison of bids. The District does not, expressly or by implication, agree that the actual amount of work will correspond therewith, and reserves the right to increase or decrease the amount of any class or portion of work, or to omit portions of the work, as may be deemed necessary or advisable by the Engineer.

1.03 EXAMINATION OF PLANS AND SITE OF WORK

- A. The Bidder shall examine carefully the site of the work contemplated, the Plans and Specifications, the Bid and Contract Forms therefor. The submission of a bid shall be conclusive evidence that the Bidder has investigated and is satisfied as to the conditions to be encountered, as to the character, quality, and scope of work to be performed and the quantities of materials to be furnished, and as to the requirements of the Bid, Plans, Addenda, and the Contract.
- B. Should the Bidder find discrepancies in, or omissions from the drawings or other Contract Documents, or should he be in doubt as to their meaning, he/she shall at once notify the Engineer who shall answer such questions.

1.04 ADDENDA

- A. All questions about the meaning or intent of the Bidding Documents are to be directed to the Engineer at (209) 249-4619. Interpretations or clarifications considered necessary by the Engineer in response to such questions will be issued by Addenda mailed or delivered to all parties recorded by the Engineer as having received the Bidding Documents. Only questions answered by formal written Addenda will be binding. Oral and other interpretations or clarifications will be without legal effect.
- B. The District or Engineer may also issue addenda to modify the Bidding Documents as deemed advisable.

1.05 BID FORMS

- A. The Engineer will furnish to each Bidder a standard Bid Form, which, when filled out and executed, may be submitted as his/her/their/its Bid. Bids not presented on forms so furnished, and copies or facsimiles of the Bidder's completed and executed Bid Forms as a bid will be rejected. Additional copies of Bid Forms may be obtained from the Engineer.
- B. The Bid shall set forth the item prices, in clearly legible figures, in the respective spaces provided, and shall be signed by the Bidder, who shall fill out all blanks in the Bid Forms as therein required.
- C. All Bidders submitting bids must sign the Bid Forms, fill out all blanks in the Bid Forms, and submit them along with all of the information and statements required herein. Any bids not containing all the information

and the "Non-collusion Declaration" requested may be considered non-responsive and may be rejected.

- D. If an individual makes the Bid, his/her/their name and mailing address must be shown. If made by a firm or partnership, the name and mailing address of the firm or partnership must be shown. If made by a corporation, the bid must show the name and mailing address of the corporation.
- E. The Bid shall be submitted as directed in the "Notice to Contractors" under sealed cover plainly marked as a bid, and identifying the project job number to which the bid relates and the date and time of the bid opening therefor. Bids which are not properly marked may be rejected.
- F. **NO CONTRACTOR OR SUBCONTRACTOR MAY BE LISTED ON A BID PROPOSAL FOR A PUBLIC WORKS PROJECT (SUBMITTED ON OR AFTER MARCH 1, 2015) UNLESS REGISTERED WITH THE DEPARTMENT OF INDUSTRIAL RELATIONS (DIR) PURSUANT TO LABOR CODE SECTION 1725.5. To register log on to the DIR website. <https://efiling.dir.ca.gov/PWCR/ActionServlet?action=displayPWCRegistrationForm>. Failure to provide DIR registration number(s) as requested in the Bid Forms will result in rejection of the Bid as non-responsive.**
- G. **ALL CONTRACTORS AND SUBCONTRACTORS MUST FURNISH ELECTRONIC CERTIFIED PAYROLL RECORDS DIRECTLY TO THE LABOR COMMISSIONER (aka DIVISION OF LABOR STANDARDS ENFORCEMENT).**
- H. **NO CONTRACTOR OR SUBCONTRACTOR MAY BE AWARDED A CONTRACT FOR PUBLIC WORK ON A PUBLIC WORKS PROJECT (awarded on or after April 1, 2015) UNLESS REGISTERED WITH THE DEPARTMENT OF INDUSTRIAL RELATIONS PURSUANT TO LABOR CODE SECTION 1725.5**
- I. **THIS PROJECT IS SUBJECT TO COMPLIANCE MONITORING AND ENFORCEMENT BY THE DEPARTMENT OF INDUSTRIAL RELATIONS.**

1.06 CONTRACTOR'S LICENSING LAWS

- A. All Contractors and Bidders submitting bids shall be properly licensed in accordance with the laws of this state and the provisions of Chapter 9 of Division 3 of the Business and Professions Code § 7028.15. Any Bidder or Contractor not so properly licensed shall be subject to the penalties imposed by such laws, and shall result in bid rejection.
- B. All Subcontractors listed in the Bidders bid form shall be licensed in accordance with the provisions of Chapter 9 of Division 3 of the Business and Professions Code and any the submission of any bid with Subcontractors not so licensed will be rejected.
- C. All businesses or individuals who construct or alter to construct or alter any building, highway, road parking facility, railroad, excavation, or other structure in California must be licensed by the California Contractors State License Board (CSLB) if the total cost (labor and materials) of one or more contracts on the project is \$500 or more. Contractors, including Subcontractors, Specialty Contractors, and persons engaged in the business of home improvement (with the exception of joint ventures and project involving federal funding) must be licensed before submitting bids. Licenses may be issued to individuals, partnerships, corporations, or joint ventures. The CSLB does not issue licenses to Limited Liability Companies (LLCs).

1.07 REQUIRED LISTING OF PROPOSED SUBCONTRACTORS

- A. Each bid shall have listed therein the name and the location of the place of business of each Subcontractor who will perform work or labor or render service to the Prime Contractor in or about the construction of the work or improvement, or a Subcontractor licensed by the State of California who, under subcontract to the Prime Contractor, specially fabricates and installs a portion of the Work or improvement according to detailed

drawings contained in the plans and specifications, in an amount in excess of one-half of 1 percent (1/2 of 1%) of the Prime Contractor's total bid. The Bid shall identify which portion of the contract work each listed Subcontractor will perform.

- B. Violations of the foregoing shall subject the Bidder to penalties accordance with the "Subletting and Subcontracting Fair Practices Act," commencing with Section 4100 of the Public Contract Code. The Bidders attention is called to other provisions of said Act relating to the imposition of penalties for failure to observe its provisions by using unauthorized Subcontractors or by making unauthorized substitutions.
- C. Listing of Subcontractors and suppliers shall be on sheets contained in the Bid Forms.
- D. Under California Public Contract Code, Section 6109, "Ineligible and Debarred Subcontractors", the Contractor is prohibited from performing work on a public works project with a Subcontractor who is ineligible to perform work on the public works project pursuant to Section 1777.1 or 1777.7 of the California Labor Code.

1.08 REJECTION OF BIDS

- A. Bids may be rejected if they have been transferred to another Bidder, or if they show any alterations of form, additions not called for, conditional or alternative bids, incomplete bids, erasures, or irregularities of any kind.
- B. Bids in which the unit prices, lump sum prices, or the total prices of the item are grossly "front- end" loaded or unbalanced with respect to costs, may be rejected.
- C. Bids submitted electronically or by facsimile will not be accepted.

1.09 BIDDER'S SECURITY

All bids shall be presented under sealed cover and shall be accompanied by one of the following forms of Bidder's security:

- A. Bidder's Bond executed by a licensed surety insurer to operate in the State of California, with an AM Best rating of "A" made payable to the District; or by a cashier's check, a certified check, or cash.
- B. The bid security shall be in an amount equal to at least ten percent (10%) of the amount bid. A Bid will not be considered unless one of the forms of Bidder's security is enclosed therewith. Bids submitted without one of the forms of Bidder's security as listed above will be rejected.

1.10 WITHDRAWAL OF BIDS

Any Bid may be withdrawn at any time prior to the time fixed in the public notice for the opening of the bids by filing a written request for the withdrawal of the Bid with the Engineer. The Bidder or his/her/their/its duly authorized representative shall execute the request. The withdrawal of a Bid does not preclude the right of the Bidder to file a new Bid prior to the time fixed for receipt of bids.

1.11 BID OPENING

- A. Whether or not bids are opened exactly at the time fixed in the "Notice to Contractors" for opening bids, a bid will not be received after that time, nor may any bid be withdrawn after the time fixed in the "Notice to Contractors" for the opening of bids.
- B. Bids will be opened and read publicly at the time and place indicated in the "Notice to Contractors." Bidders or their authorized agents are invited to be present.

1.12 RELIEF OF BIDDER

If the Bidder claims a mistake was made in his/her/their/its Bid, he/she/they/it shall give the Engineer written notice within five (5) working days, excluding Saturdays, Sundays, and holidays, after the opening of bids of the alleged mistake specifying in the notice in detail how the mistake occurred in accordance with Public Contract Code § 5100 et seq.

1.13 DISQUALIFICATION OF BIDDERS

More than one (1) bid from an individual, firm, or partnership, corporation, or combination thereof under the same or different names will not be considered. Reasonable grounds for believing that any individual, firm partnership, corporation or combination thereof is interested in more than one bid for the work contemplated may cause the rejection of all bids in which that individual, firm partnership, corporation or combination thereof is interested. If there is reason for believing that collusion exists among the Bidders, any or all bids may be rejected. Bids in which the prices are obviously unbalanced may be rejected

1.14 RESPONSIBLE BIDDER

Public Contract Code, Section 1103, defines "Responsible Bidder" as one "who has demonstrated the attribute of trustworthiness, as well as quality, fitness, capacity, and experience to satisfactorily perform the public works contract."

1.15 SCHEDULE OF CONTRACT AWARD

- A. **Award of Contract** — If award is made, Contract will be awarded to the lowest responsive, responsible bidder whose Bid complies with the specified requirements. Notice of award will be sent to the successful bidder at the mailing address indicated in bidder's submittal.
- B. Determination of the lowest monetary bid will be determined by the lowest total of the bid prices on the base contract and those additive or deductive items that were specifically identified in the bid solicitation as being used for the purpose of determining the lowest bid price.
- C. Additional Alternative Bid Items will be considered to be included in the contract at the discretion of the District.
- D. In the event of a tie, the District Board may accept, for award, the bid it chooses by a publicly held coin toss.
- E. The District reserves the express right to waive minor defects in bids that are deemed to be "non-material" by the District.
- F. The District reserves the right to reject all bids.

END OF DOCUMENT 00102

DOCUMENT 00201

BID FORMS

PROJECT NO. SSJID-26003 MAIN OFFICE PAVEMENT IMPROVEMENT PROJECT PHASE 2

CONTRACTOR: _____

BID ITEM	DESCRIPTION	UNITS	ESTIMATED QUANTITY	UNIT PRICE	TOTAL ESTIMATED PRICE
1.	Mobilization & Demobilization, Insurance & Bonding	LS	1		
2.	Water Pollution Control (BMPs)	LS	1		
3.	Temporary Access, Traffic Control, and Gate Coordination	LS	1		
4.	Full-Depth Pavement Removal & Replacement (3" AB + 3" AC)	SF	19,315		
5.	Remove & Replace Striping & Wheel Stops	LS	1		
6.	Remove & Replace 8" Thick Reinforced Concrete	SF	335		
7.	Remove & Replace Concrete Valley Gutter	SF	395		
8.	Asphalt Pavement Coating	SY	2,975		
9.	Remove & Replace 6" Storm Drain Pipe	LF	128		
10.	Remove & Replace 12" Storm Drain Pipe	LF	142		
11.	Asphalt Concrete Dike (Type A)	LF	131		
12.	Joint Trench Conduit (3ea-4" PVC SCH. 40 & 3ea-2" PVC SCH. 40)	LF	92		
13.	B2436 Pull Box with H20 Rated Steel Lid	EA	3		

The undersigned declares he/she has carefully examined the location of the proposed work, that he/she has examined the plans, and read the accompanying instructions to Bidders, and hereby proposes to furnish all labor, materials, tools, equipment, and incidentals, and do all work required to complete the said Work in accordance with the Plans and Specifications for the unit prices set forth in the following schedule:

TOTAL BID AMOUNT (Items #1-#13) \$ _____

TOTAL BID AMOUNT IN WORDS:

IN THE EVENT OF DISCREPANCY BETWEEN FIGURES AND WORDS, WORDS SHALL PREVAIL

DATED: _____

If Bidder is:

An Individual

Name (typed or printed): _____

By: _____
(Individual's Signature)

Doing business as: _____

Business Address: _____

Phone Number: (____) _____ FAX Number: (____) _____

A Partnership

Partnership Name: _____

By: _____
(Signature of general partner – attach evidence of authority to sign)

Name (typed or printed): _____

Business Address: _____

Phone Number: (____) _____ FAX Number: (____) _____

A Corporation

Corporation Name: _____

State of Incorporation: _____

Type (General Business, Professional, Service Limited Liability): _____

By: _____
(Signature – attach evidence of authority to sign)

Name (typed or printed): _____

Title: _____

Attest: _____
(Signature of Corporate Secretary, Acting Secretary or other officer)

Business Address: _____

Phone Number: (____) _____ FAX Number: (____) _____

Date of Qualification to do business is _____

A Joint Venture

Joint Venture Name: _____

By: _____
(Signature of joint venture partner – attach evidence of authority to sign)

Name (typed or printed): _____

Title: _____

Business Address: _____

Phone Number: (____) _____ FAX Number: (____) _____

Joint Venturer Name: _____

By: _____
(Signature of joint venture partner – attach evidence of authority to sign)

Name (typed or printed): _____

Title: _____

Business Address: _____

Phone Number: (____) _____ FAX Number: (____) _____

Phone and FAX Number, and Address for receipt of official communications:

(Each joint venturer must sign. The manner of signing for each individual, partnership, and corporation that is a party to the joint venture should be in the manner indicated above.)

AWARD OF PROPOSED WORK

The District reserves the right to reject any and all bids. The award, if made, will be made to the lowest single responsive and responsible Bidder as submitted.

CONTRACTOR'S LICENSE STATEMENT

CALIFORNIA CONTRACTOR'S LICENSE NUMBER: _____

LICENSE EXPIRATION DATE: _____

CONTRACTOR'S DIR REGISTRATION NUMBER STATEMENT

CALIFORNIA DEPARTMENT OF INDUSTRIAL RELATIONS REGISTRATION NUMBER: _____

ACKNOWLEDGMENT OF ADDENDA

Bidder has examined and carefully studied the Bidding Documents, the other related data identified in the Bidding Documents, and the following Addenda, receipt of which is hereby acknowledged.

ADDENDUM NO.: _____ _____ _____ _____

CONTRACTOR'S INITIAL _____ _____ _____ _____

LIST OF PROPOSED SUBCONTRACTORS

Listed hereinafter are the names and addresses of all Subcontractors who will be employed, and the kind of work which each will perform if the contract is awarded to the undersigned. I understand that under Public Contract Code Section 4100 et seq. (4104), I must clearly set forth:

- (c) The name, the location of the place of business, and the California contractor's license number, and DIR Registration Number of each subcontractor who will perform work or labor or render service to the prime contractor in or about the construction of the work or improvement, or a subcontractor licensed by the State of California who, under subcontract to the prime contractor, specially fabricates and installs a portion of the work or improvement according to detailed drawings contained in the plans and specifications, in an amount in excess of one-half of 1 percent of the Prime Contractor's total bid.
- (b) The portion of the work which will be done by each Subcontractor under this act. The Prime Contractor shall list only one (1) Subcontractor for each portion as is defined by the Prime Contractor in his/her/their/its bid.
- (c) Violations of this Act, the Prime Contractor shall be subject to penalties set forth in Public Contract Code Sections 4110 and 4111.

Portion of Work	Name, Place of Business	Cal. Const. Lic.#	DIR Regist. #

THE BIDDER MUST COMPLETE THE FOLLOWING QUESTIONNAIRE

QUESTIONNAIRE

Has the Bidder, any officer of the Bidder, or any employee of the Bidder who has a proprietary interest in the Bidder, ever been disqualified, removed, or otherwise prevented from bidding on, or completing a Federal, State, or Local government project because of a violation of law or a safety regulation?

YES _____

NO _____

If the answer is "yes", explain the circumstances in the following space:

NOTE: This questionnaire constitutes a part of the Bid Form, and signature on the signature portion of the Bid Form shall constitute execution of this questionnaire.

FAIR EMPLOYMENT PRACTICES CERTIFICATION

The Bidder, in submitting a bid for performing the following work by contract, hereby certifies that he has or will meet the standards of affirmative compliance with the Fair Employment Practices Act relating to the work herein.

This certificate constitutes a part of the Bid Form, and signature on the signature portion of the Bid Form shall constitute execution of this certification

**NONCOLLUSION DECLARATION
TO BE EXECUTED BY BIDDER AND SUBMITTED
WITH BID**

The undersigned declares:

I am the _____(title)
of the party making the foregoing Bid.

The Bid is not made in the interest of, or on behalf of, any undisclosed person, partnership, company, association, organization, or corporation.

The Bid is genuine and not collusive or sham.

The Bidder has not directly or indirectly induced or solicited any other bidder to put in a false or sham bid.

The Bidder has not directly or indirectly colluded, conspired, connived, or agreed with any bidder or anyone else to put in a sham bid, or to refrain from bidding.

The Bidder has not in any manner, directly or indirectly, sought by agreement, communication, or conference with anyone to fix the bid price of the bidder or any other bidder, or to fix any overhead, profit, or cost element of the bid price, or of that of any other bidder.

All statements contained in the Bid are true.

The Bidder has not, directly or indirectly, submitted his/her/their/its bid price or any breakdown thereof, or the contents thereof, or divulged information or data relative thereto to any corporation, partnership, company association, organization, bid depository, or to any member or agent thereof, to effectuate a collusive or sham bid, and has not paid, and will not pay, any person or entity for such purpose.

Any person executing this declaration on behalf of a bidder that is a corporation, partnership, joint venture, limited liability Company, limited liability partnership, or any other entity, hereby represents that he or she has full power to execute, this declaration on behalf of the bidder.

I declare under perjury under the laws of the State of California the foregoing is true and correct and that this declaration is executed on _____
20____, at City of _____, State of _____

(signature)

(print name of person signing)

END OF DOCUMENT 00201

DOCUMENT 00202

BID BOND

KNOW ALL MEN BY THESE PRESENTS,

that we, the undersigned, _____ as principal and
_____ as Surety, are hereby held and firmly
bound unto the _____ in the penal sum of
_____ for the payment of which, well and truly to be made, we hereby jointly
and severally bind ourselves, our heirs, executors, administrators, successors and assigns.

SIGNED, this ____ day of _____, 20 ____.

The Condition of the above obligation is such that whereas the Principal has submitted to the _____
_____ a certain bid, attached hereto and hereby made a part hereof to enter
into a Contract in writing, for the construction of improvements as set forth in the Contract documents for
the _____.

NOW THEREFORE,

- (a) If said Bid shall be rejected, or in the alternate,
- (b) If said Bid shall be accepted and the Principal shall execute and deliver a Contract in the form of Agreement attached hereto (properly completed in accordance with said Bid) and shall in all other respects perform the agreement created by the acceptance of said Bid,

then this obligation shall be void, otherwise the same shall remain in force and effect; it being expressly understood and agreed that the liability of the Surety for any and all claims hereunder shall, in no event, exceed the penal amount of this obligation as herein stated. The Surety, for value received, hereby stipulates and agrees that the obligations of said Surety and its bond shall in no way be impaired or affected by any extension of time within which the _____ may accept such Bid; and Surety does hereby waive notice of any such extension.

In the event the _____ notifies Surety in writing that the Principal's Bid has been accepted, but that the Principal has failed to execute the form of Agreement and provide the requisite bonds and insurance, within seven (7) days after the Principal was notified of the acceptance of his/her/their/its Bid, and a copy of such notice has been sent to the Principal, then the Surety shall pay the amount of this bond to the _____ within ten (10) days after receipt of such notice.

IN WITNESS WHEREOF, the Principal and the Surety have hereunto set their hands and seals, and such of them as are corporations have caused their corporate seals to be hereto affixed and these presents to be signed by their proper officers, the day and year first set forth above.

*****SIGNATURES APPEAR ON THE FOLLOWING PAGE*****

Principal

By_____

By_____

(seal)

Surety

By_____

By_____

(seal)

END OF DOCUMENT 00202

**CONTRACT
FOR
MAIN OFFICE PAVEMENT IMPROVEMENT PROJECT PHASE 2
PROJECT NO. SSJID-26003**

This Contract is made and entered into this _____ day of _____, 20____, in the County of San Joaquin, California, by and between SOUTH SAN JOAQUIN IRRIGATION DISTRICT, an irrigation district organized under the California Water Code ("District"), with its District Office located at 11011 E. Highway 120, Manteca, California 95336-9750, and _____, with its principal place of business at _____ ("Contractor").

AGREEMENT

1. SCOPE OF WORK

The Project consists of furnishing all traffic control, materials, equipment, labor, tools, and incidentals required to complete the following work:

Full-depth removal and replacement of approximately 19,315 square feet of asphalt concrete pavement, including subgrade preparation, compaction, placement of aggregate base, and placement of 3/4-inch Type A Hot Mix Asphalt (HMA). Removed materials shall be stockpiled at a designated on-site location. Additional work includes removal and replacement of striping and wheel stops; removal and replacement of approximately 335 square feet of 8-inch-thick reinforced concrete; removal and replacement of approximately 395 square feet of concrete valley gutter; application of asphalt pavement coating to approximately 2,975 square yards of existing pavement; Installation of joint trench conduit including pull boxes; and removal and replacement of approximately 128 linear feet of 6-inch storm drain pipe and 142 linear feet of 12-inch storm drain pipe. Work also includes temporary access, traffic control, coordination to maintain District operations, and implementation of water pollution control measures. The Contractor shall coordinate all work with District staff to maintain access and minimize disruption to District operations.

Contractor shall begin the work when issued a Notice to Proceed by District. It is expected that all work, with the exception of asphalt pavement coating, will be completed within **30 CALENDAR DAYS**. Asphalt pavement coating shall be completed within **75 CALENDAR DAYS** to allow newly placed asphalt concrete to cure prior to application.

2. TERM OF CONTRACT

This Contract shall be effective immediately and shall remain in effect until the Work described in Section 1 is completed.

3. COMPENSATION AND CLAIMS FOR EXTRA WORK

The compensation to be paid by District to Contractor for satisfactory completion of the work shall be _____ Dollars and ____/100 cents (\$_____).

The Contractor shall be responsible for ascertaining the nature and location of the work, and the general and local conditions which can affect the work or the cost thereof. Any failure by the Contractor to do so will not relieve it from responsibility for successfully performing the work without additional expense to the District. Except as expressly provided to the contrary in the Contract, the Contractor assumes all risk with respect to unforeseen difficulties which may be encountered in performance of the Work.

If the Contractor claims that any instructions issued by District involve extra cost under this Contract, Contractor shall give District written notice thereof within five (5) calendar days after the receipt of such instructions. No such claim shall be binding on District until accepted by District.

4. INVOICING AND PAYMENT

A. Progress Estimates - From time to time, the Contractor will prepare a progress estimate and request for payment for work performed. Within ten (10) days after receipt, the District will review the progress estimate and respond in writing to the Contractor, the amount approved by District as the value of all work under the Contract, including any amounts due the Contractor for extra work or pursuant to approved claims for extra. In arriving at the value of the work done, the District will give consideration to the value of major items which have been delivered to the job site for incorporation in the Work and for which payment in full has been made by the Contractor. Consideration will not be given to preparatory work done or other materials on hand.

B. Progress Payments - The District will pay the Contractor ninety-five percent (95%) of the amount of each progress estimate approved by District within 10 days after District's approval of the progress estimate. Five percent (5%) of the amount of each estimate shall be retained by the District until final completion and acceptance of all Work under the Contract. No partial payment or estimate shall constitute an acceptance of the Work or any portion thereof.

C. Acceptance and Final Payment - Whenever the Contractor shall deem all Work under this Contract to have been completed in accordance therewith, it shall so notify the District in writing, and the District shall promptly ascertain whether such be the fact and, if not, shall advise the Contractor in detail and in writing of any additional work required. When all the provisions of the Contract have been fully complied with to the satisfaction of the District, the District shall proceed with all reasonable diligence to determine accurately the total value of all work performed by the Contractor at the prices set forth in the accepted Proposal or fixed by Change Orders and the total value of all Extra Work, if any, all in accordance with the Contract. Within fifteen (15) days after completion and acceptance by the District's Board of Directors, the difference between said final estimate and all payments theretofore made to the Contractor shall be due and payable to the Contractor and excepting only such sum or sums as may lawfully be withheld in accordance with the provisions of this Contract. All prior certifications upon which partial payments may have been made, being merely estimates, shall be subject to correction in the final certificate. Acceptance by the Contractor of said payment made in accordance with said final estimate shall operate as and shall be a release to the District, its officers, agents, and employees from all claims and liability to the Contractor for anything done or furnished or withheld, and for anything relating to the work or any act or neglect of the District, its officers, agents, and employees, excepting only claims against the District for any amounts withheld by the District at the time of such payment.

D. Right of District to Withhold Payments - In addition to all other rights and remedies of the District hereunder and by virtue of law, the District may withhold or nullify the whole or any part of any partial or final payment to such extent as may reasonably be necessary to protect the District from loss on account of:

- (1) Defective work not remedied, irrespective of when any such work is found to be defective;
- (2) Claims or liens filed or reasonable evidence indicating probable filing of claims or liens;
- (3) Failure of the Contractor to make payments properly for labor, materials, equipment, or other facilities, or to subcontractors;
- (4) A reasonable doubt that the work can be completed for the balance then unearned;
- (5) Damage to work or property.

Whenever the District shall, in accordance herewith, withhold any monies otherwise due the Contractor, written notice of the amount withheld and the reasons therefor will be given the Contractor. After the Contractor has corrected the enumerated deficiencies the District shall promptly pay to the Contractor the amount so withheld. When monies are withheld to protect the District against claims or liens of mechanics, materialmen, subcontractors, etc., the District may at its discretion permit the Contractor to deliver a surety bond in terms and amount satisfactory to the District, indemnifying the District against any loss or expense, and upon acceptance thereof by the District, the District shall release to the Contractor monies so withheld.

5. NOTICES. Any notices or other communications to be given pursuant to this Contract shall be given by delivering same in writing to the parties at the addresses set forth below:

DISTRICT	CONTRACTOR
<i>If by overnight or hand-delivery, to:</i> South San Joaquin Irrigation District 11011 East Highway 120 Manteca, CA 95336-9570 <i>If by U.S. Mail, to:</i> South San Joaquin Irrigation District P.O. Box 747 Ripon, CA 95336-09750	<i>If by overnight or hand-delivery, to:</i> <i>If by U.S. Mail, to:</i>

Such notice shall be deemed given when deposited into the United States mail, postage prepaid, addressed to the parties at the addresses above. Nothing shall preclude the giving of personal notice or notice by e-mail provided, however, that notice by e-mail shall be followed by notice deposited into the United States mail as discussed above.

6. INDEPENDENT CONTRACTOR

A. It is understood and agreed that Contractor (including Contractor's employees) is an independent contractor and that no relationship of employer-employee exists between the parties hereto. Contractor shall not be entitled to any benefits payable to employees of District. District is not required to make any deductions or withholdings from the compensation payable to Contractor under the provisions of this Contract; and as an independent contractor, Contractor hereby indemnifies and holds District harmless from any and all claims that may be made against District based upon any contention by any third party that an employer-employee relationship exists by reason of this

B. It is further understood and agreed by the parties hereto that Contractor in the performance of its obligation hereunder is subject to the control or direction of District as to the designation of tasks to be performed, and the results to be accomplished but not the means, methods or sequence used by Contractor for accomplishing the results.

C. If, in the performance of this Contract, any third persons are employed by Contractor, such persons shall be entirely and exclusively under the direction, supervision, and control of Contractor. All terms of employment, including hours, wages, working conditions, discipline, hiring, and discharging, or any other terms of employment or requirements of law, shall be in accordance with applicable Federal and State Law, including the provisions of Labor Code section 1771 requiring the payment of prevailing wages on public works projects.

D. It is further understood and agreed that as an independent contractor and not an employee or agent of District, neither Contractor nor Contractor's assigned personnel shall have any right to act on behalf of District in any capacity whatsoever as agent, or to bind District to any obligation whatsoever.

E. It is further understood and agreed that Contractor must issue W-2 Forms or other suitable tax forms for income and employment tax purposes, for all of Contractor's assigned personnel under the terms and conditions of this Contract.

7. INDEMNIFICATION

A. Contractor, by execution of this Contract, specifically agrees to hold harmless, defend and indemnify District, its directors, officers, agents, and employees from and against any and all actions, claims, loss, liability, damage and expense including reasonable attorney's fees caused or alleged to be caused by any negligent or willful act or omission of Contractor, Contractor's employees or subcontractors engaged by Contractor in connection with the work of Contractor.

B. The Contractor shall assume the defense of and indemnify and save harmless the District against any and all liens, actions, claims loss, liability, damage and expense including attorney's fees, for labor and material furnished to the Contractor or any of its subcontractors in connection with the performance of this Contract. In the event that the Contractor or any of its subcontractors shall fail to pay for any material or labor used in the performance of this Contract, or any lien is filed against the said property, or any claim is asserted or action filed on any Bond, by any person claiming to have furnished labor or materials to the Contractor or any of subcontractors in connection with the performance of this Contract, the District shall be entitled, at its option, to pay for said material or labor, or discharge any such lien, or to pay

or settle any such claim or action and to deduct the amount so paid, together with any and all costs and attorney's fees incurred by or on behalf of the District in connection with any such payment, discharge, or settlement, from amounts due or to become due the Contractor hereunder.

C. Contractor shall indemnify and save harmless the District, and its directors, officers, employees and agents from any and all actions, claims, loss, liability, damage, and expense, including all costs and expenses of District, including reasonable attorneys' fees, arising out of any failure of Contractor to comply with federal, state, or local laws or regulations or Contractor's failure to comply with any other obligation of Contractor in this Contract.

8. INSURANCE

During the performance of the Work under this Contract, Contractor and each subcontractor retained by Contractor shall maintain the following insurance:

A. General Liability Insurance, with a combined single limit of \$1,000,000 for each occurrence and \$1,000,000 in the aggregate.

B. Automobile Liability Insurance, with a combined single limit of \$1,000,000 for each person and \$1,000,000 for each accident.

C. Worker's compensation insurance in accordance with statutory requirements.

District shall be named as a named insured on the General Liability policies. Contractor shall, furnish District certificates for the liability insurance which shall include a provision that such insurance shall not be canceled without at least thirty (30) days' written notice to District. All subcontractors shall be required to include District and Contractor as additional insureds on their General Liability insurance policies, and shall be required to indemnify District and Contractor to the same extent. Insurance policies required under this contract shall be issued by an insurer with a rating of at least "A" in the latest edition of A.M. Best's Insurance Guide.

9. DOCUMENTATION TO BE FURNISHED BY CONTRACTOR

Prior to the start of construction, Contractor shall furnish District with the following documents:

A. Contractor prior to commencing work shall sign and file with the District a Workers' Compensation Certificate.

B. Written evidence of Contractor's state contractor's license number.

C. Certificate of Liability Insurance naming the District as additional insured meeting the requirements below.

D. For contracts exceeding \$25,000.00 Faithful Performance Bond and Payment Bond, each in the full amount of the Contract Price.

E. For contracts exceeding \$25,000.00 proof of Contractor's and all subcontractors' current registration with the Department of Industrial Relations to perform public work pursuant to Labor Code Section 1725.5.

F. Trench safety plan if required.

G. Contractor Safety Agreement

10. SUBCONTRACTS

The attention of the Contractor is directed to the provisions of Public Contract Code, Section 4100 et seq. as amended, and said provisions are by this reference incorporated herein and made a part hereof.

Each subcontract shall contain a suitable provision for the suspension or termination thereof should the work be suspended or terminated or should the subcontractor neglect or fail to conform to every provision of the Contract Documents insofar as such provisions are relevant. The Contractor shall be as fully responsible for the acts or omissions of its subcontractors and of the persons either directly or indirectly employed by them as it is for the acts or omissions of persons directly employed by him. Nothing contained in the Contract Documents shall create any contractual relation between any subcontractor and the District.

11. COMPLIANCE WITH LAWS - PERMITS - TAXES

The Contractor is an independent contractor and shall, at its sole cost and expense, comply with all laws, rules, ordinances and regulations of all governing bodies having jurisdiction over the work, obtain all necessary permits and licenses therefor, pay all manufacturers' taxes, sales taxes, use taxes, processing taxes, and all Federal and State taxes, insurance and contributions for Social Security and Unemployment which are measured by wages, salaries or any remuneration paid to the Contractor's employees, whether levied under existing or subsequently enacted laws, rules, or regulations. The Contractor shall also pay all property tax assessments on materials or equipment used until acceptance by the District. Without limitation, materials furnished and performance by the Contractor hereunder shall comply with Safety Orders of the Division of Industrial Safety, State of California.

The Contractor, upon request, shall furnish evidence satisfactory to the District that any or all of the foregoing obligations have been or are being fulfilled. The Contractor warrants to the District that it is licensed by all applicable governmental bodies to perform this Contract and will remain so licensed throughout the progress of the work, and that it has, and will have, throughout the progress of the Work, the necessary experience, skill, and financial resources to enabled it to perform this Contract.

12. SAFETY

A. Trench Safety Plan. Before beginning excavation for any trench or trenches required under this Contract, the Contractor shall furnish to the District working drawings of Contractor's trench safety plan. The trench safety plan working drawings shall be a detailed plan showing the design or shoring, bracing, sloping or other provisions to be made for worker protection from the hazard of caving ground. Plans varying from the shoring system standards established by the Construction Safety Orders of the California Division of Industrial Safety or the Federal Safety Standards of the Department of Health, Education and Welfare, the plan must be prepared by a registered civil or structural engineer. In no event shall the Contractor use a shoring, sloping, or protective system less effective than that required by said Construction Safety Orders, or less effective than that required by said Federal Safety Standards.

B. General. The Contractor shall be solely and completely responsible for the conditions of the job site, including safety of all persons and property during performance of the work. This requirement shall apply continuously and not be limited to normal working hours. Safety provisions shall conform to all applicable Federal, State, County and local laws, ordinances, and codes, and to the rules and regulations established by the California Division of Industrial Safety, and to other rules of law applicable to the work.

C. Contractor Safety Agreement. The Contractor shall complete, sign, and submit to the District a Contractor Safety Agreement as provided in the project's documents before project commencement.

13. WORKERS AND WAGES

A. Character of Workers - Only qualified, careful and efficient workers shall be employed. When required in writing by the District, the Contractor or any subcontractor shall remove from the work any person who is, in the opinion of the District, incompetent, unfaithful, disorderly, or otherwise unsatisfactory, and shall not again employ such person on the work except with the consent of the District. Such removal shall not be the basis for any claim for compensation or damages against the District, or any of its officers or agents.

B. Hours of Work - Eight (8) hours of labor shall constitute a legal day's work upon all the work hereunder and the time of service of any worker employed by the Contractor or by any subcontractor under it shall be limited and restricted to eight (8) hours during any one (1) calendar day, except that work performed by employees in excess of eight (8) hours per day and forty (40) hours in any one (1) calendar week will be permitted upon compensation for all hours worked in excess of said limitations at not less than one and one-half times the basic rate of pay or as otherwise may be required by applicable law. The Contractor and all subcontractors under it shall keep record of hours worked as required by Section 1812 of the California Labor Code. As required by Section 1813 of the California Labor Code, the Contractor shall forfeit as a penalty to the District twenty-five dollars (\$25) for each worker employed in the execution of the Contract by it or by any subcontractor under it for each calendar day during which such worker is required or permitted to work more than eight (8) hours in any one (1) calendar day and forty (40) hours in any one (1) calendar week in violation of the provisions of this subsection.

C. Compliance with State Requirements for Employment of Apprentices - The Contractor's attention is directed to Section 1777.5 of the California Labor Code; provisions of said section pertaining to employment of registered apprentices are hereby incorporated by reference into these Specifications. As applicable, the Contractor or any subcontractor employed by it in the performance of Contract work shall take such actions as necessary to comply with provisions of said Section 1777.5.

D. Wage Rates and Certified Payroll - Pursuant to Article 2 (commencing at Section 1770), of the California Labor Code, the Director of the State of California, Department of Industrial Relations has ascertained the generally prevailing rate of per diem wages and the generally prevailing rates for legal holiday and overtime work in the locality in which the work is to be performed, for each craft or type of worker needed to execute the Contract. The Contractor and all subcontractors under it shall pay not less than said specified rates to all workers employed in the execution of the Contract. As required by Section 1775 of the California Labor Code, the Contractor shall, as a penalty to the District, forfeit an amount determined by the Labor Commissioner, not more than two hundred dollars (\$200), for each calendar day, or portion thereof, for each worker paid less than the specified prevailing rates for work done under the Contract by it or by any subcontractor under him. The Contractor and all subcontractors under it shall keep certified payroll records of wages paid as required by Section 1776 of the California Labor Code. Contractor and all subcontractors must furnish electronic certified payroll records directly to the Division of Labor Standards Enforcement, if required. The Contractor and each sub-contractor shall pay travel and subsistence payments to each worker needed to execute the work required by the Contract, as such travel and subsistence payments are defined in the applicable collective bargaining agreements filed in accordance with Section 1773.8 of the California Labor Code. The labor rates determined by the Department of Industrial Relations are set forth in a schedule located at the District office, which is available to any interested party upon request.

E. Job Site Posting – Contractor shall comply with the job site posting requirements in California Labor Code Section 1771.4.

F. Registration With the Department of Industrial Relations – Contractor shall comply with the registration requirements and certified payroll filing requirements of the Department of Industrial Relations (“DIR”), if the Contract Price exceeds: 1) \$25,000.00 for new construction, alteration, installation, demolition, or repair; or \$15,000.00 for maintenance. For Construction projects exceeding \$25,000.00 and maintenance projects exceeding \$15,000.00, no contractor or subcontractor may be listed on a bid proposal for public works unless registered with the DIR, pursuant to California Labor Code Section 1725.5. No contractor or subcontractor may be awarded a public works contract unless registered with the DIR pursuant to California Labor Code Section 1725.5.

G. Compliance and Monitoring – Contractor’s performance of work under this Agreement is subject to compliance monitoring and enforcement by the California Department of Industrial Relations.

H. Labor Management Agreements - The Contractor agrees to comply with the provisions of all Master Labor Agreements and similar agreements between labor and management to which Contractor is a party with respect to labor employed by Contractor in the performance hereof, including the making of all payments to health, welfare and pension funds and trusts, payments for vacations and apprentice contributions, and other fringe benefits, and prohibitions against payment for piece work, bonus system, quota setting, lumping of work, and set cost basis; and agrees to hold the District harmless from liability or expense on account of all the foregoing. In the event of a jurisdictional dispute, or threatened dispute, involving Contractor’s employees, Contractor shall follow the direction of the District in the settlement or elimination thereof and take all steps necessary to continue with the work without interruption. If so directed by the District, Contractor further agrees to immediately submit any such dispute to the National Joint Board for Settlement of Jurisdictional Disputes, Building and Construction Industry, and to be bound by the final decision of said Joint Board. A jurisdictional dispute shall not entitle the Contractor to an extension of time for performance or to extra compensation or damages; and the Contractor assumes all risks with regard to such disputes.

I. Worker’s Compensation Insurance - In accordance with the provisions of Section 3700 of the California Labor Code, Contractor shall secure the payment of compensation to its employees. Contractor prior to commencing work shall sign and file with the District a certification in the form attached as **Exhibit B**.

J. Labor Discrimination - Contractor agrees to comply with provisions of Labor Code section 1735 that reads as follows:

A contractor shall not discriminate in the employment of persons upon public works on any basis listed in subdivision (a) of Section 12940 of the Government Code, as those bases are defined in Sections 12926 and 12926.1 of the Government Code, except as otherwise provided in Section 12940 of the Government Code. Every contractor for public works who violates this section is subject to all the penalties imposed for a violation of this chapter.

Contractor agrees to ensure compliance with the provisions of California Labor Code section 1777.6, which provide as follows:

An employer or a labor union shall not refuse to accept otherwise qualified employees as registered apprentices on any public works on any basis listed in subdivision (a) of Section 12940 of the Government Code, as those bases are defined in Sections 12926 and 12926.1 of the Government Code, except as provided in Section 3077 of this code and Section 12940 of the Government Code.

14. NOTICE OF LATENT OR HAZARDOUS CONDITIONS

In accordance with Section 7104 of the Public Contract Code, where the contract specifications require digging trenches or excavating deeper than four (4) feet below the surface, the Contractor shall promptly, and before the following conditions are disturbed, notify the District, in writing, of any:

(a) Material that the Contractor may believe is hazardous waste as defined in Section 25117 of the Health and Safety Code, that is required to be removed to a Class I, Class II, or Class III disposal site in accordance with provisions of existing law;

(b) Subsurface or latent physical conditions at the site differing from those indicated by information about the site made available to bidders prior to the deadline for submitting bids;

(c) Unknown physical conditions of any unusual nature, materially different from those ordinarily encountered and generally recognized as inherent in work of the character provided for in the contract specifications.

Upon receipt of written notice by the Contractor of such conditions, the District shall promptly investigate. If the District finds such conditions to exist and determine that an increase or decrease in the Contractor's cost of, or time required for, performance of the work will result from the change in conditions, the District will issue a change order.

In the event a dispute arises between the District and the Contractor as to whether the conditions materially differ, or involve hazardous waste, or cause decrease or increase in the cost of or time required for performance of any part of the work, the Contractor shall not be excused from the scheduled completion of the work, and shall retain any and all rights which he may have pertaining to the resolution of disputes between the District and the Contractor.

15. PROTECTION OF DISTRICT FACILITIES; UTILITIES

Contractor shall repair any damage to District's facilities caused by Contractor at its own expense.

The Contractor shall be responsible for the removal, relocation and protection of all public and private utilities, including irrigation facilities, bridges and embankments located on the site of the construction project if and to the extent that the same are identified in the plans, specifications or other contract documents, and the Contractor shall not be entitled to any extension of time or claim for damages or extra compensation in connection therewith. If and to the extent that such utilities or facilities are not identified in such Contract documents, as between the Contractor and the District, the District will be responsible for the cost of their removal, relocation or protection, as the case may be.

16. GOOD AND WORKMANLIKE SERVICES

Contractor shall perform the work in a good and workmanlike manner. District shall have access to the work for purposes of inspecting the work to determine that it is being performed in accordance with this Contract.

17. CLAIMS

Claims must be filed with the District within the time frame set forth in this Agreement, but in any event on or before the date of final payment. Contractor shall observe the following procedure taken from Chapter 9 of Part 1 of Division 2 of the Public Contract Code.

- A. "Claim" means a separate demand by the Contractor sent by registered mail or certified mail with return receipt requested, for one or more of the following:
- 1) A time extension, including, without limitation, for relief from damages or penalties for delay assessed by the District.
 - 2) Payment by the District of money or damages arising from work done by, or on behalf of, the Contractor pursuant this contract and payment for which is not otherwise expressly provided or to which the Contractor is not otherwise entitled.
 - 3) Payment of an amount that is disputed by the District.
 - 4) Upon receipt of a claim pursuant to this section, the District shall conduct a reasonable review of the claim and, within a period not to exceed 45 days, shall provide the Contractor a written statement identifying what portion of the claim is disputed and what portion is undisputed. Upon receipt of a claim, the District and the Contractor may, by mutual agreement, extend the time period provided in this section.
- B.
- 1) The Contractor shall furnish reasonable documentation to support the claim.
 - 2) If the District needs approval from its Board of Directors to provide the Contractor a written statement identifying the disputed portion and the undisputed portion of the claim, and the Board of Directors does not meet within the 45 days or within the mutually agreed to extension of time following receipt of a claim sent by registered mail or certified mail, return receipt requested, the District shall have up to three days following the next duly publicly noticed meeting of the Board of Directors after the 45-day period, or extension, expires to provide the Contractor a written statement identifying the disputed portion and the undisputed portion.
 - 3) Any payment due on an undisputed portion of the claim shall be processed and made within 60 days after the District issues its written statement. If the District fails to issue a written statement, paragraph (D) shall apply.
- C.
- 1) If the Contractor disputes the District's written response, or if the District fails to respond to a claim issued pursuant to this section within the time prescribed, the Contractor may demand in writing an informal conference to meet and confer for settlement of the issues in dispute. Upon receipt of a demand in writing sent by registered mail or certified mail, return receipt requested, the District shall schedule a meet and confer conference within 30 days for settlement of the dispute.
 - 2) Within 10 business days following the conclusion of the meet and confer conference, if the claim or any portion of the claim remains in dispute, the District shall provide the Contractor a written statement identifying the portion of the claim that remains in dispute and the portion that is undisputed. Any payment due on an undisputed portion of the claim shall be processed and made within 60 days after the District issues its written statement. Any disputed portion of the claim, as identified by the Contractor in writing, shall be submitted to nonbinding mediation, with the District and the Contractor sharing the associated costs equally. The District and Contractor shall mutually agree to a mediator within 10 business days after the disputed portion of the claim has been identified in writing. If the parties cannot agree upon a mediator, each party shall select a mediator and those mediators shall select a qualified neutral third party to mediate with regard to the disputed portion of the claim. Each party shall bear the fees and costs charged by its respective mediator in connection with the selection of the neutral mediator. If mediation is unsuccessful, the parts of the claim remaining in dispute shall be subject to applicable procedures outside this section.
 - 3) For purposes of this section, mediation includes any nonbinding process, including, but not limited to, neutral evaluation or a dispute review board, in which an independent third party

or board assists the parties in dispute resolution through negotiation or by issuance of an evaluation. Any mediation utilized shall conform to the timeframes in this section.

- 4) Unless otherwise agreed to by the District and the Contractor in writing, the mediation conducted pursuant to this section shall excuse any further obligation under Section 20104.4 to mediate after litigation has been commenced.
- D. Failure by the District to respond to a claim from the Contractor within the time periods described in this subdivision or to otherwise meet the time requirements of this section shall result in the claim being deemed rejected in its entirety. A claim that is denied by reason of the District's failure to have responded to a claim, or its failure to otherwise meet the time requirements of this section, shall not constitute an adverse finding with regard to the merits of the claim or the responsibility or qualifications of the Contractor.
- E. Amounts not paid in a timely manner as required by this section shall bear interest at seven percent (7%) per annum.
- F. If a subcontractor or a lower tier subcontractor lacks legal standing to assert a claim against the District because privity of contract does not exist, the Contractor may present to the District a claim on behalf of a subcontractor or lower tier subcontractor. A subcontractor may request in writing, either on his/her/their own behalf or on behalf of a lower tier subcontractor, that the Contractor present a claim for work which was performed by the subcontractor or by a lower tier subcontractor on behalf of the subcontractor. The subcontractor requesting that the claim be presented to the District shall furnish reasonable documentation to support the claim. Within 45 days of receipt of this written request, the Contractor shall notify the subcontractor in writing as to whether the Contractor presented the claim to the District and, if the Contractor did not present the claim, provide the subcontractor with a statement of the reasons for not having done so.

18. NOTICE OF THIRD PARTY CLAIMS. District shall notify Contractor as soon as is practical, but in any event no more than five (5) days within receipt of any third party claim related to this Contract.

19. SUSPENSION OF WORK; TERMINATION

A. District may at any time, by notice in writing to the Contractor, suspend any part of the work for such period of time as may be necessary to prevent improper execution of the work on the project, and the Contractor shall have no claim for damages or additional compensation on account of any such suspension.

B. District shall have the right to terminate this Contract at any time by serving upon Contractor five (5) days advance written notice of termination. The notice shall be deemed served and effective for all purposes on the date it is deposited in the United States mail, postage prepaid and addressed to Contractor at the address indicated in Section 5. In the event District issues such notice of termination:

- 1) Contractor shall immediately cease rendering services pursuant to this Contract.
- 2) District shall pay Contractor for work performed up to the effective date of termination.

20. AMENDMENTS. Modifications or amendments to the terms of this Contract shall be in writing and executed by both parties.

21. ASSIGNMENT. Contractor shall not assign or transfer its duties, responsibilities or interests pursuant to this Contract without the express written consent of District.

22. **SURVIVAL**. The indemnity provisions of Section 7 shall survive the expiration or other termination of this Contract.

23. **GOVERNING LAW**. This Agreement shall be governed by the laws of the State of California.

24. **ENTIRE AGREEMENT**. This instrument and any attachments hereto constitute the entire contract between the District and Contractor concerning the subject matter hereof.

IN WITNESS WHEREOF, the parties hereto have caused this Contract to be duly executed as of the day and year first written above.

“DISTRICT”
SOUTH SAN JOAQUIN IRRIGATION DISTRICT

“CONTRACTOR”
BY _____

(name,
title) _____

BY _____
Peter M. Rietkerk, General Manager

BY _____
Glenn Spyksma, President
Board of Directors

END OF DOCUMENT 00301

**DOCUMENT 00302
FAITHFUL PERFORMANCE BOND**

KNOW ALL MEN BY THESE PRESENTS

THAT, WHEREAS, the SOUTH SAN JOAQUIN IRRIGATION DISTRICT, State of California, entered into a Contract dated _____, 20____, with _____

hereinafter designated as the "Contractor," for MAIN OFFICE PAVEMENT IMPROVEMENT PROJECT PHASE 2 (SSJID-26003)

WHEREAS, the said Contractor is required under the terms of said Contract to furnish a bond for the faithful performance of said Contract.

NOW, THEREFORE, WE, the undersigned Contractor, as Principal, and _____
(corporate surety), a corporation organized and existing under the laws of the State of _____,

and duly authorized to transact business under the laws of the State of California, as Surety, are held and firmly bound unto SOUTH SAN JOAQUIN IRRIGATION DISTRICT in the penal sum of _____ Dollars (\$_____), lawful money of the United States, said sum being equal in amount to one-hundred percent (100%) of the total Contract amount payable by the said SOUTH SAN JOAQUIN IRRIGATION DISTRICT under the terms of the Contract, for the payment of which sum well and truly to be made, we bind ourselves, our heirs, executors, administrators, and successors, jointly and severally, firmly by these presents.

THE CONDITION OF THIS OBLIGATION IS SUCH, THAT, if the above bonded Contractor, his/her/their/its heirs, executors, administrators, successors or assigns, shall in all things stand to and abide by, and well and truly keep and perform the covenants, conditions and agreements in the said Contract and any alteration thereof made as therein provided, on his/her/their/its part, to be kept and performed at the time and in the manner therein specified, and in all respects according to their true intent and meaning, and shall indemnify and save harmless the SOUTH SAN JOAQUIN IRRIGATION DISTRICT, its officers and agents, as therein stipulated, then this obligation shall become null and void; otherwise it shall be and remain in full force and effect.

And the said Surety, for value received, hereby stipulates and agrees that no change, extension of time, alteration or addition to the terms of the Contract or to the work to be performed thereunder or the Specifications accompanying the same shall in any way affect its obligations on this bond, and it does hereby waive notice of any such change, extension of time, alteration or addition to the terms of the Contract or to the work or to the Specifications.

IN WITNESS WHEREOF, WE, have hereunto set our hands and seals this _____ day of _____, 20____.

Contractor: _____

Surety: _____

By: _____

By: _____

Title: _____

Title: _____

By: _____

Address: _____

Title: _____

Phone: _____

Attorney-in-Fact: _____

Address: _____

Phone: _____

Seal: _____

NOTE: This bond must be acknowledged before a notary public, and a legally sufficient power of attorney must be attached to the bond to verify the authority of any party signing on behalf of a surety.

END OF DOCUMENT 00302

**DOCUMENT 00303
PAYMENT BOND**

KNOW ALL MEN BY THESE PRESENTS

THAT, WHEREAS, the SOUTH SAN JOAQUIN IRRIGATION DISTRICT has awarded to _____ hereinafter designated as the "Contractor," a Contract for MAIN OFFICE PAVEMENT IMPROVEMENT PROJECT PHASE 2 (SSJID-26003); and,

WHEREAS, said Contractor is required by the provisions of Division 4, Part 6, Title 3, Chapter 5 of the Civil Code of the State of California, including Section 9550, to furnish a bond in connection with said Contract, as hereinafter set forth.

NOW, THEREFORE, WE, _____ the undersigned Contractor, as Principal, and _____ a corporation organized and existing under the laws of the State of _____, and duly authorized to transact business under the laws of the State of California, as Surety, are held and firmly bound unto the SOUTH SAN JOAQUIN IRRIGATION DISTRICT in the sum of _____ Dollars (\$ _____), lawful money of the United States, said sum being equal in amount to one-hundred percent (100%) of the total Contract amount payable by the said SOUTH SAN JOAQUIN IRRIGATION DISTRICT under the terms of the Contract, for which payment well and truly to be made, we bind ourselves, our heirs, executors and administrators, successors and assigns, jointly and severally, firmly by these presents.

THE CONDITION OF THIS OBLIGATION IS SUCH, THAT, if said Contractor, his/her/their/its heirs, executors, administrators, successors or assigns, or subcontractors, shall fail to pay for any materials, provisions, implements or machinery used in, upon, for or about the performance of the work contracted to be done, or for any work or labor thereon of any kind, or for amounts due under the Unemployment Insurance Code with respect to such work or labor, as required by the provisions of Section 9554 of the Civil Code or amounts required to be deducted, withheld, and paid over to the Employment Development Department from the wages of employees of the contractor and subcontractors under Section 13020 of the Unemployment Insurance Code with respect to the work and labor; and provided that the claimant shall have complied with the provisions of said Codes, the surety or sureties hereon will pay for the same in an amount not exceeding the sum specified in this bond, otherwise the above obligation shall be void. In case suit is brought upon this bond, the said Surety will pay a reasonable attorney's fee to be fixed by the court. This bond shall inure to the benefit of any and all persons, companies and corporations entitled to file claims under Section 9100 of the Civil Code, so as to give a right of action to them or their assigns in any suit brought upon this bond. And the said Surety, for value received, hereby stipulates and agrees that no change, extension of time, alteration or addition to the terms of the Contractor to the work to be performed thereunder or the Specifications accompanying the same shall in any way affect its obligations on this bond, and it does hereby waive notice of any such change, extension of time, alteration or addition to the terms of the Contract or to the work or to the Specifications.

IN WITNESS WHEREOF, WE have hereunto set our hands and seals this _____ day of _____,

20__.

Contractor: _____

By: _____

Title: _____

Surety: _____

By: _____

Title: _____

Home/Office

Address: _____

Phone: _____

Attorney-in-Fact: _____

Address: _____

Phone: _____

Seal: _____

NOTE: This bond must be acknowledged before notary publics, and a legally sufficient power of attorney must be attached to the bond to verify the authority of any party signing on behalf of a surety.

END OF DOCUMENT 00303

DOCUMENT 00304
WORKER'S COMPENSATION INSURANCE CERTIFICATE

In accordance with California Labor Code Section 1861, prior to commencement of work on the Contract, the Contractor shall sign and file with South San Joaquin Irrigation District the following certification:

"I am aware of the provisions of Section 3700 of the Labor Code which require every employer to be insured against liability for worker's compensation or to undertake self-insurance in accordance with the provisions of that code, and I will comply with such provisions before commencing the performance of the work of this Contract."

Signature

Name of Contractor

Title

Date

Contractor's License Number

Telephone Number

END OF DOCUMENT 00304

DOCUMENT 00305

Contractor Safety Agreement

South San Joaquin Irrigation District (SSJID) wishes to ensure that all work done on our site(s) will be performed in accordance with all applicable environmental health and safety laws, codes, and regulations. The Contractor is required to provide all documentation indicated in the appropriate box(es). Failure to provide information as required may result in disqualification.

Contractor Safety Requirement Acknowledgement

1. Contractor will provide a written Injury and Illness Prevention Plan compliant with 8 CCR 3203 (please check one).	<input type="checkbox"/> Yes	<input type="checkbox"/> No
Or		
2. Contractor is an individual contractor. All work will be performed in compliance with all laws, codes, regulations, and best practices to protect personnel, property, and the environment.	<input type="checkbox"/> Yes	<input type="checkbox"/> No

Initial each item for acknowledgement of Safety Requirement. If the item is not applicable, write "N/A".

Item Description	Initials or N/A
3. Contractor will provide SSJID with a copy of their Hazard Communication program if their employees will be using any chemicals on the job.	_____
4. Contractor will provide SSJID with a copy of the SDS for each chemical brought onto the site.	_____
5. Contractor will provide SSJID with a copy of the Hazardous Waste Disposal Plan and Manifest for any hazardous waste generated during the job including asbestos and lead. Also will provide training certifications for asbestos and lead work, PFT and fit test documents for employees involved at the worksite.	_____
6. Contractor will provide SSJID with a copy of their Lockout/Tagout program if any work is to be performed on any sources of hazardous energy.	_____
7. Contractor will provide SSJID with a copy of their Electrical Safety program if any electrical work is being performed.	_____
8. Contractor will provide SSJID with a copy of their Fall Protection program if any work is to be performed that would require it.	_____
9. Contractor will provide SSJID with a copy of the Confined Space program if any confined spaces are to be entered, including a list of employees that are certified for confined space entry.	_____
10. Contractor will provide SSJID with a copy of their accident investigation report for each accident that occurs during the performance of the contract.	_____
11. Contractor will provide SSJID with documentation of required training as per 8 CCR 1541, Excavation and Trenching Standard, for all employees involved in excavation and trenching operations, including certification of the competent person in charge of excavation and trenching operations.	_____
12. Contractor will provide SSJID with documentation of required training as per the latest edition of the U.S. Department of Transportation Federal Highway Administration, Manual on Uniform Traffic Control Devices for Streets and Highways and MUTCD 2014 California Supplement for all employees involved in traffic control and flagging operations.	_____

Contractor Company Name

Representative Signature

Date

END OF DOCUMENT 00305

DOCUMENT 00401

GENERAL CONDITIONS

SECTION 1 - GENERAL

1.01 GENERAL

- A. Unless the context otherwise requires, whenever in the specifications and other contract documents the following terms are used, the intent and meaning shall be interpreted as provided herein.
- B. Working titles having a masculine gender, and the pronoun "he" are utilized in the specifications for sake of brevity, and are intended to refer to persons of any gender.

1.02 DEFINITIONS

- A. Acceptance - The formal written acceptance by the District of an entire contract, which has been completed in all respects in accordance with the plans and specifications and any modifications thereof, see Notice of Completion.
- B. Bid - The offer of the bidder setting forth the prices for the work, when filled out and submitted on the prescribed Bid Form, properly signed and guaranteed.
- C. Bid Forms - The forms upon which the District requires formal bids to be prepared and submitted for the Work.
- D. Bid Bond or Guarantee - The cash, cashier's check, certified check, or bidder's bond accompanying the Bid documents submitted by the Bidder, as a guaranty that the Bidder will enter into a contract with the District for the performance of the Work awarded to him.
- E. Bidder - An individual, firm, partnership, corporation or combination thereof submitting a Bid for the work contemplated, acting directly or through a duly authorized representative.
- F. Bond - A Bidder's bond, faithful performance bond, payment bond, or other instrument of security.
- G. Change Order – A document recommended by Engineer, which is signed by Contractor and District and authorizes an addition, deletion, or revision in the Work or an adjustment in the Contract Price or the Contract Times, issued on or after the Effective Date of the Agreement.
- H. Claim – A demand or assertion by District or Contractor seeking an adjustment of Contract Price or Contract Times, or both, or other relief with respect to the terms of the Contract. A demand for money or services by a third (3rd) party is not a Claim.
- I. Contract - The written agreement covering the performance of the work and the furnishing of labor, materials, tools, and equipment in the construction of the work. The contract shall include the notice to contractors, Bid, plans, specifications, special provisions, addenda, and contract bonds; also any and all supplemental agreements amending or extending the work contemplated and which may be required to complete the work in a substantial and acceptable manner. Supplemental agreements are written agreements covering alterations, amendments, or extensions to the contract and include contract change orders.
- J. Contract Documents - The contract documents shall include the Notice Inviting Bids, Instructions to Bidders, Addenda, Bid (including documentation accompanying the Bid and any post-bid documents submitted prior to award), the Bonds, the General Conditions, the

Special Provisions, permits from other agencies, the Plans, Specifications, reference specifications, and all modifications issued after execution of the Contract.

- K. Contract Price – The moneys payable by District to Contractor for completion of the Work in accordance with the Contract Documents as stated in the Agreement.
- L. Contract Times – The number of days or the dates stated in the Agreement to: (i) achieve Final Completion; and (ii) complete the Work so that it is ready for final payment after acceptance by District.
- M. Contractor - The person or persons, firm, partnership, corporation, or combination thereof, private or municipal who have entered into a contract with the District as party or parties of the second part, or his/her/their/its legal representatives.
- N. District - Whenever the word "District" is used it shall be understood to mean and refer to the South San Joaquin Irrigation District, acting by or through its duly elected or appointed officers or officials or their authorized agents.
- O. Days - Unless otherwise designated, days as used in the Contract Documents shall mean consecutive calendar days.
- P. Engineer - South San Joaquin Irrigation District Engineering Department Manager or his/her/their/its appointed designee who shall also be a licensed engineer.
- Q. Notice of Completion - A written Notice of Completion signed and verified by the District or representative shall be recorded with the County Recorder of the County in which the work was performed. The date of completion and acceptance of the work by the District or representative recited in the Notice of Completion shall be deemed to be the date of Completion.
- R. Notice to Proceed - A written notice given by the Engineer to the Contractor fixing the date on which the Contract time will start.
- S. Plans - The official project plans, profiles, typical cross-sections, general cross-sections, working plans, or reproductions thereof, approved by the Engineer, which show the locations, character, dimensions, and details of the work to be performed. All such documents are to be considered as part of the plans.
- T. Project – The total construction of which the Work to be performed under the Contract Documents may be the whole, or a part as may be indicated elsewhere in the Contract Documents.
- U. Shop Drawings – All drawings, diagrams, illustrations, schedules, and other data or information, which are specifically prepared or assembled by or for Contractor and submitted by Contractor to illustrate some portion of the Work.
- V. Special Provisions - The special provisions are specific clauses setting forth conditions or requirements peculiar to the work and supplementary to the Specifications.
- W. Specifications - The directions, provisions and requirements contained in these specifications, special provisions, technical specifications, and addenda.
- X. State - Whenever the word "State" is used it shall be understood to mean and refer to the State of California.
- Y. State Specifications - The Standard Specifications of the State of California, which shall be more particularly identified, if necessary, in the Plans and Specifications.

- Z. Work - All the Work specified, indicated, shown or contemplated in the contract to construct the improvements, including all alterations, amendments or extensions thereto made by contract change order or written orders of the Engineer.

SECTION 2 - AWARD AND EXECUTION OF CONTRACT

2.01 AWARD OF CONTRACT

- A. The right is reserved to reject any and all Bids.
- B. The award of the Contract, if awarded, will be to the lowest responsive and responsible Bidder whose Bid complies with all the requirements prescribed. Such award, if made, will be made within sixty (60) days after the opening of the Bids. If the lowest responsive Bidder refuses or fails to execute the contract, the District may award the contract to the second lowest responsive and responsible Bidder. Such award, if made, will be made within seventy-five (75) days after the opening of the Bids. If the second lowest responsive and responsible refuses to execute the contract, the District may award the contract to the third lowest responsive and responsible Bidder. **Bidder's Bid shall remain valid for at least ninety (90) days.** The periods of time specified above within which the award of contract may be made shall be subject to extension for such further period as may be agreed upon in writing between the District, the Bidder and the Bidder's surety concerned.
- C. All bids will be compared on the basis of the Engineer's estimate of quantities of work to be done.
- D. The procedure for selection of low Bidder, if identical bids are received: Upon opening and reviewing the bids received, if the District determines that two or more bidders have submitted identical monetary bids, and that said bidders are deemed to be responsive, responsible bidders, and that there is no other factor that can be used to determine which bidder is the lowest responsive, responsible bidder to whom the contract should be awarded, then and in that event the lowest responsive, responsible bidder shall be determined by a publicly held "flip-of-the coin." The District shall notify each such Bidder submitting identical bids of the date, time and place at which the coin flip shall take place. One bidder shall flip the coin and the second bidder shall call "heads or tails" while the coin is in the air. The Bidder calling the correct side shall be deemed to be the lowest, responsive, responsible bidder. In the event that there are more than two bids of the same amount, then there shall be a succession of coin flips to place the bids in consecutive order for purposes of determining the order of the lowest monetary bidders. If a Bidder fails to attend the coin flip, then District representatives shall represent the Bidder not in attendance.
- E. Additive and Deductive Items (§20103.8):

District may require a bid for a public works contract to include prices for items that may be added to, or deducted from, the Scope of Work in the contract for which the bid is being submitted. Whenever additive or deductive items are included in a bid, the bid solicitation shall specify which one of the following methods will be used to determine the lowest bid. In the absence of a specification, only the method provided by subdivision a) will be used.

 - a) The lowest bid shall be the lowest bid price on the base contract without consideration of the prices on the additive or deductive items.

- b) The lowest bid shall be the lowest total of the bid prices on the base contract and those additive or deductive items that were specifically identified in the bid solicitation as being used for the purpose of determining the lowest bid price.
- c) The lowest bid shall be the lowest total of the bid prices on the base contract and those additive or deductive items that when taken in order from a specifically identified list of those items in the solicitation, and added to, or subtracted from, the base contract, are less than, or equal to, a funding amount publicly disclosed by the District before the first bid is opened,
- d) The lowest bid shall be determined in a manner that prevents any information that would identify any of the bidders or proposed subcontractors or suppliers from being revealed to the public entity before the ranking of all bidders from lowest to highest has been determined.

2.02 CONTRACT BONDS

- A. Prior to commencement of work under the Contract, the Bidder shall furnish the District with surety bonds in the amounts and for the purposes listed herein. The successful Bidder shall furnish two (2) good and sufficient surety bonds:
 - 1. "Payment" bond shall secure the payment of claims of laborers, mechanics, or material suppliers employed on the work under the contract.
 - 2. "Performance" bond shall guarantee faithful performance of all work, within the time prescribed, in a manner satisfactory to the District, and that all materials and workmanship will be free from original or developed defects. The performance bond shall remain in effect until the end of all warranty periods set forth in the Contract documents.
- B. The form of bonds shall be surety forms conforming to California standards or as stipulated in the Special Provisions. Each contract bond shall be in the amount of one hundred percent (100%) of the Contract amount.
- C. All alternates, extensions of time, extra and additional work, and other changes authorized by these specifications or any part of the contract may be made without securing the consent of the surety or sureties on the contract bonds. Changes, alterations, or extensions in the terms of the Contract shall not release the Contractor or their surety from its obligations.
- D. Special forms of bond required may be examined at the office of the Engineer, or copies will be furnished, if desired, to prospective bidders.
- E. Whenever any surety or sureties on any such bonds, or on any bonds required by law for the protection of the claims of laborers and material suppliers, become insufficient, or the District has cause to believe that such surety or sureties have become insufficient, a demand in writing may be made of the Contractor for such further bond or bonds or additional surety, not exceeding that originally required, as is considered necessary, considering the extent of the work remaining to be done. Thereafter no payment shall be made upon such contract to the Contractor or any assignee of the Contractor until such further bond or bonds or additional surety has been furnished.
- F. Companies supplying sureties or bonds shall be admitted to supply such instruments within the State of California, shall be listed by the Office of the Insurance Commissioner, and shall have a minimum A.M. Best rating of "A" and have a demonstrated ability to meet their ongoing obligations to policyholders.

- G. Each bond shall incorporate, by reference, the Contract and shall be signed by both the Bidder and the Surety, and the signature of the authorized agent of the Surety shall be notarized. The Bidder shall pay all bond premiums, costs, and incidentals.

2.03 EXECUTION OF CONTRACT

- A. The Contract shall be signed by the successful Bidder and returned, together with the contract bonds within fifteen (15) days after the bidder has received notice that the contract has been awarded unless stipulated otherwise in the Special Provisions. No Bid shall be considered binding upon the District until the execution of the Contract.

2.04 FAILURE TO EXECUTE CONTRACT

- A. Failure of the lowest responsive and responsible Bidder, or the second lowest responsive and responsible Bidder or the third lowest Bidder to execute the contract and file acceptable bonds as provided herein within fifteen (15) days after such Bidder has received the Contract for execution shall be just cause for the annulment of the award and a claim against the Bid guaranty.

2.05 RETURN OF BID GUARANTEE

- A. The Bid guarantee accompanying the Bids of the first, second, and third lowest responsive and responsible Bidders will be retained until the Contract has been awarded and executed by both parties to the Contract, after which all such Bid guarantees, except Bidders' bonds and any guarantees which are subject to claims, will be returned to the respective Bidders whose Bids they accompany. The Bid guarantees submitted by all other unsuccessful Bidders will be returned upon determination, by the Engineer, of the first, second, and third lowest responsive Bidders.

SECTION 3 - SCOPE OF WORK

3.01 INTENT OF PLANS AND SPECIFICATIONS

- A. The intent of the plans and specifications is to prescribe the details for the construction and completion of the work, which the Contractor undertakes to perform in accordance with the terms of the contract. Where the plans or specifications describe portions of the work in general terms, but not in complete detail, it is understood that only the best general practice is to prevail, and that only materials and workmanship of the first quality are to be used.

3.02 WORK TO BE DONE

- A. Unless otherwise specified, the Contractor shall furnish all labor, materials, tools, implements, equipment, machinery, methods, processes, and incidentals, and do all the work involved in executing the work in a satisfactory and workmanlike manner.

3.03 CHANGES

- A. The District reserves the right to make such alterations, deviations, additions to or deletions from the plans and specifications including the right to increase or decrease the quantity of any item or portion of the work, or to delete any item or portion of the work, as may be deemed by the Engineer to be necessary or advisable and to require such extra work as deemed by the Engineer to be required for the proper completion or construction of the whole work contemplated.
- B. Any such changes will be set forth in a contract change order which will specify, in addition to the work to be done in connection with the change made, adjustment of contract time, if any,

and the basis for compensation for such work. A contract Change Order will not become effective until approved by the District.

3.04 INCREASED OR DECREASED QUANTITIES

- A. Increases or decreases in the quantity of a contract item of work will be determined by comparing the total pay quantity of such item of work with the Engineer's Estimate thereof. If the total pay quantity of any item of work required under the contract varies from the quantities indicated in the Bid by twenty-five percent (25%) or less, payment will be at contract unit prices.
- B. If the total pay quantity of any item of work required under the Contract varies from the quantities indicated in the Bid by more than twenty-five percent (25%), in the absence of an executed contract Change Order specifying the compensation to be paid, payment will be at contract prices. Written requests by the Contractor shall be accompanied by adequate data to support the costs of the item.

3.05 FINAL CLEANING UP

- A. Before final inspection of the Work, and as a condition of the acceptance and final payment, the Contractor shall clean the project site, and all ground occupied or used by Contractor in connection with the work, of all rubbish, excess materials, temporary structures, and equipment. All parts of the work shall be left in a neat and presentable condition.

SECTION 4 - CONTROL OF WORK

4.01 AUTHORITY OF ENGINEER

- A. The Engineer shall decide all questions which may arise as to the quality or acceptability of materials furnished and work performed, and as to the manner of performance and rate of progress of the work; all questions which may arise as to the interpretation of the plans and specifications; all questions as to the acceptable fulfillment of the contract on the part of the Contractor; and all questions as to claims and compensation. The Engineer's decision shall be final and he shall have executive authority to enforce and make effective such decisions and orders which the Contractor fails to carry out promptly.

4.02 PLANS

- A. The Contract Plans furnished consist of general plans and show such details as are necessary to give a comprehensive idea of the construction contemplated. All authorized alterations affecting the requirements and information given on the approved plans shall be in writing.
- B. The Contract Plans shall be supplemented by such working drawings/shop drawings prepared by the Contractor as are necessary to adequately control the work. The Contractor shall make no change to any working drawings/shop drawings after the Engineer has approved it, except by direction of the Engineer.
- C. The Contractor's working drawings/shop drawings for any part of the permanent work shall include, but not be limited to, stress sheets, anchor bolt layouts, shop details, erection plans, equipment lists and any other information specifically required elsewhere in the specifications.
- D. Working drawings/shop drawings for any structures and for other temporary work and methods of construction the Contractor proposes to use shall be submitted when required by the specification or ordered by the Engineer. Such drawings shall be subject to approval insofar as the details affecting the character of the finished work and for compliance with

design requirements applicable to the construction when specified or called for, but details of design will be left to the Contractor who shall be responsible for the successful construction of the Work.

- E. The Engineer shall approve working drawings/shop drawings before any work involving such drawings is performed. It is expressly understood that approval of the Contractor's working drawings/shop drawings shall not relieve the Contractor from his/her/their/its responsibility under the Contract for the successful completion of the Work in conformity with the requirements of the plans and specifications. Such approval shall not waive any of the requirements of the plans and specifications or relieve the Contractor of any obligation there under, and defective work, materials, and equipment may be rejected notwithstanding such approval.

4.03 CONFORMITY WITH PLANS AND ALLOWABLE DEVIATION

- A. Work and materials shall conform to the lines, grades, typical cross sections, dimensions and material requirements, including tolerances, shown on the plans or indicated in the specifications. Although measurement, sampling and testing may be considered evidence as to such conformity, the Engineer shall be the sole judge as to whether the materials or work deviate from the plans and specifications, and his/her/their/its decision as to any allowable deviations there from shall be final.
- B. Deviations from the approved plans, as may be required by the exigencies of construction, will be determined in all cases by the Engineer and authorized in writing.

4.04 COORDINATION AND INTERPRETATION OF PLANS, SPECIFICATIONS, AND SPECIAL PROVISIONS

- A. The specifications, special provisions, addenda, Contract Change Orders, the plans, and all supplementary documents are essential parts of the contract, and a requirement occurring in one is as binding as though occurring in all. They are intended to be complementary, to describe, and to provide for a complete work.
- B. In the event of conflicts between the contract documents the order or precedence shall be as follows:
 - 1. Modifications or changes last in time are first in precedence.
 - 2. Addenda.
 - 3. General Conditions except for specific modifications thereto stated in the Special Provisions or Division 01 Specifications.
 - 4. Special Provisions.
 - 5. Specifications.
 - 6. Should there be a conflict among the General Conditions, Special Provisions, and the Plans and Specifications the more restrictive will apply.
 - 7. Plans; as between figures given on plans and the scaled measurements, the figures shall govern; as between large-scale plans and small-scale plans, the larger scale shall govern.
 - 8. As between detailed plans and standard plates bound within the specifications, the detailed plans govern.
 - 9. In the event where provisions of codes, safety orders, contract documents, manufacturer's specifications, or industry standards are in conflict, the more restrictive shall govern.

4.05 REQUESTS FOR INFORMATION

- A. Should it appear that the work to be done, or any matter relative thereto, is not sufficiently

detailed or explained in the plans, specifications, or the special provisions, the Contractor shall submit a request for information to the Engineer for such further explanations as may be necessary, on forms provided by the Engineer. The Contractor shall comply with the Engineer's response as part of the Contract. In the event of any doubt or question arising respecting the true meaning of the plans, specifications, or the special provisions, reference shall be made to the Engineer, whose decision thereon shall be final.

4.06 DIFFERING SITE CONDITIONS

- A. The Contractor shall promptly, no more than one (1) day, and before conditions are disturbed, give written notice to the Engineer as to subsurface or latent physical conditions at the site which differ materially from those indicated in the contract documents, or unknown physical conditions at the site of an unusual nature which differ materially from those normally encountered and generally recognized as inherent in the work of the character provided for in the contract.
- B. No request by the Contractor for additional compensation shall be allowed unless the Contractor has given the written notice as required herein.

4.07 SUPERINTENDENCE

- A. The Contractor shall designate in writing before starting work an authorized representative who shall have the authority to represent and act for the Contractor. Said authorized representative shall be present at the site of the work at all times while work is actually in progress on the Contract. When work is not in progress and during periods when work is suspended, arrangements acceptable to the Engineer shall be made for any emergency work that may be required.
- B. Whenever the Contractor, or his/her/their/its authorized representative, is not present on any particular part of the work where it may be desired to give direction, Contractor shall assign one (1) and have on the work site a competent superintendent who is satisfactory to the Engineer and has authority to act for the Contractor.

4.08 LINES AND GRADES

- A. Lines and grades are established as those areas existing or adjacent to the work.
- B. The Contractor shall furnish the Engineer such facilities and labor necessary for marking and maintaining points and lines as he may require.

4.09 INSPECTION

- A. The District and Engineer shall at all times have safe access to the Work during construction, and shall be furnished with every reasonable facility for ascertaining that the materials and workmanship are in accordance with the requirements and intentions of the specifications, special provisions, and the plans. All work done and all materials furnished shall be subject to inspection.
- B. Whenever the Contractor varies the period which work is carried out on each day, notice shall be given the Engineer, so that inspection may be provided. Any work done in the absence of the Engineer, may be subject to rejection.
- C. The inspection of the work or material shall not relieve the Contractor of any of his/her/their/its obligation to fulfill the contract as prescribed. Work or materials not meeting such requirements shall be made good, and unsuitable materials may be rejected, notwithstanding the fact that such work or materials have been previously inspected by the District or Engineer or the payment

therefore has been included in a progress estimate.

- D. Projects financed in whole or in part with City, County, State and/or Federal funds shall be subject to inspection at all times by the agencies involved.

4.10 REMOVAL OF DEFECTIVE AND UNAUTHORIZED WORK

- A. All work which has been rejected, shall be remedied, or removed and replaced by the Contractor in an acceptable manner, and no compensation, will be allowed for such removal, replacement, or remedial work.
- B. Any work done beyond the lines and grades shown on the plans or established by the Engineer, or any extra work done without written authority, will be considered as unauthorized and will not be paid for. Upon order of the Engineer unauthorized work shall be remedied, removed, or replaced at the Contractor's expense.
- C. Upon failure on the part of the Contractor to comply forthwith with any order of the Engineer made under provisions of this section, the Engineer shall have authority to cause defective work to be remedied, or removed and replaced, and unauthorized work to be removed, and to deduct the costs thereof from any moneys due or to become due the Contractor.

4.11 CHARACTER OF WORKERS

If any Subcontractor or person employed by the Contractor shall appear to the Engineer to be incompetent or to act in a disorderly or improper manner, such Subcontractor or person shall be discharged immediately on request of the Engineer, and such person shall not again be employed on the Work.

4.12 FINAL INSPECTION

Whenever the work covered by the Contract has been satisfactorily completed in accordance with the Contract Documents, and the final cleanup performed, the Engineer will make the final inspection.

4.13 CONTRACTOR'S GUARANTY

- A. The complete Project, including all work, materials, devices and equipment, shall be guaranteed by the Contractor against faulty workmanship and materials for a period of three (3) years from the date of recording of the Notice of Completion. The Contractor shall be responsible for all repair and/or replacements including all labor, materials, equipment, devices, plant and other items of work necessary.
- B. To secure the Contractor's Guarantee, the Performance bond specified in Section 2.02 of the General Conditions shall continue in full force and effect for a period of three (3) years from the date of recording of the Notice of Completion.
- C. The Contractor may be required to furnish a written guaranty covering certain items of work for periods of time longer than three (3) years as stipulated above. Such item shall be stipulated in the Special Provisions or as designated by the Engineer. The performance bond shall be extended or other suitable guaranty shall be provided prior to acceptance of the work. Where covered by the Special Provisions, the extended guaranty shall be included in the contract price, where designated by the Engineer, the Contractor will be reimbursed for bond premium in conjunction with the extended guaranty.

SECTION 5 - CONTROL OF MATERIALS

5.01 GENERAL

- A. The Contractor shall furnish all materials or equipment required to complete the work, except

materials that are designated in the specifications to be furnished by the District. Only materials and equipment conforming to the requirements of the specifications shall be incorporated into the work.

- B. All materials and equipment furnished by the Contractor shall be new and, free from defects. Where the quality of materials or equipment is not specifically called out they shall be of the highest quality normally used.

5.02 CONTRACTOR'S SUBMITTALS

The Contractor shall submit to the Engineer for his/her/their approval, catalog and descriptive literature on materials or equipment that will be used in the Work, if required in the Specifications.

5.03 SAMPLES AND TESTS

- A. At the option of the Engineer, the Engineer shall approve the source of supply of each of the materials or equipment before delivery is started and before such materials or equipment is used in the work. Samples of such materials or equipment shall be furnished to the Engineer as requested and without charge. No material or equipment shall be used until the Engineer has approved it. Samples will be secured and tested whenever necessary to determine the quality of material or equipment.
- B. All tests of materials or equipment furnished by the Contractor shall be made in accordance with commonly recognized standards of national testing organizations, and such special methods and tests as are prescribed in these specifications.

5.04 STORAGE OF MATERIALS

Articles or materials to be incorporated in the work shall be stored in such a manner as to insure the preservation of their quality and fitness for the work, and to facilitate their inspection.

5.05 DEFECTIVE MATERIALS

- A. All material or equipment which does not conform to the requirements of the Plans and Specifications shall be considered as defective and all such materials or equipment, whether in place or not, shall be rejected. They shall be removed immediately from the site of the work, unless otherwise permitted by the Engineer. No rejected material or equipment, the defects of which have been subsequently corrected, shall be used unless approved in writing by the Engineer.
- B. Upon failure on the part of the Contractor to comply promptly with any order of the Engineer made under the provisions of this section, the Engineer shall have authority to cause the removal and replacement of defective material or equipment and to deduct the cost thereof from any moneys due, or to become due to the Contractor.

5.06 MANUFACTURED EQUIPMENT

Manufactured equipment shall be all new, first line, current production models of manufacturers regularly engaged in production of such equipment for at least five (5) years.

5.07 TRADE NAMES AND ALTERNATIVES

- A. For convenience in designation on the plans or in the specifications, certain articles, materials or equipment to be incorporated in the work may be designated under a trade name or the name of a manufacturer and its catalog information. The use of an alternative article or material which is of equal quality and of the required characteristics for the purpose intended will be permitted, subject to the following requirements:
 1. The burden of proof as to the quality and suitability of alternatives shall be upon the

Contractor and he shall furnish all information necessary as required by the Engineer. The Engineer shall be the sole judge as to the quality and suitability of alternative articles or materials and his/her/their decision shall be final.

2. Whenever the specifications permit the substitution of a similar or equivalent material or article, no tests or action relating to the approval of such substitute material will be made until the request for substitution is made in writing by the Contractor accompanied by complete data as to the equality of the material or article proposed. Such request shall be made in ample time to permit approval without delaying the work.

B. Any additional costs incurred to allow the use of alternate material or equipment shall be borne by the Contractor, and shall not be the basis for any claim or claims for extra compensation. Any savings resulting from the use of alternate material or equipment shall be deducted from any moneys due, or that may become due the Contractor under the Contract.

5.08 PLANT INSPECTION

The Engineer shall have the right to inspect the production of material, or manufacture of products at the source of supply.

SECTION 6 - LEGAL RELATIONS AND RESPONSIBILITIES TO THE PUBLIC

6.01 LAWS TO BE OBSERVED

The Contractor shall keep himself fully informed of all existing and future State and Federal laws and all County, Municipal, Local and Special District laws, ordinances and regulations which in any manner affect those engaged or employed in the work, or the materials used in the work, or which in any way affect the conduct of the work, and of all such orders and decrees of bodies or tribunals having any jurisdiction or authority over the same. The Contractor shall at all times observe and comply with, and shall cause all his/her/their/its agents and employees to observe and comply with all such existing and future laws, ordinances, regulations, orders and decrees of bodies or tribunals having any jurisdiction or authority over the work; and shall protect and indemnify the District, and all officers and employees thereof connected with the work, including the Engineer, against any claim or liability arising from or based on the violation of any such law, ordinance, regulation, order, or decree, whether by himself or his/her/their/its employees. If any discrepancy or inconsistency is discovered in the plans, specifications, or contract for the work in relation to any such law, ordinance, regulation, order, or decree the Contractor shall forthwith report the same to the Engineer in writing.

6.02 CONTRACTORS LICENSING LAWS

All Bidders, Contractors, and Subcontractors performing work under this contract must be licensed by the California Contractors State License Board in accordance with the provisions of Chapter 9 of Division 3 of the Business and Professions Code and any Bidder, Contractor, or Subcontractor not so licensed shall be subject to the penalties imposed by such laws.

6.03 ASSIGNMENT OF ANTITRUST ACTIONS

Sections 4551 through 4554 of the Government Code pertaining to the assignment of antitrust claims are incorporated herein in full by this reference.

6.04 PAYMENT OF TAXES

The contract prices paid for the work shall include full compensation for all taxes which the Contractor is required to pay, whether imposed by Federal, State, County, or local government, including, without being limited to, Federal excise tax. The District will furnish no tax exemption certificate or any document designed to exempt the Contractor from payment of any tax to the Contractor.

6.05 PERMITS AND LICENSES

The Contractor shall procure all permits and licenses, pay all charges and fees, and give all notices necessary and incidental to the due and lawful prosecution of the work.

6.06 PATENTS

The Contractor shall assume all responsibilities arising from the use of patented materials, equipment, devices, or processes used on or incorporated in the work and agrees to indemnify and save harmless the District, Engineer, and their duly authorized representatives, from all suits at law, or actions of every nature for or on account of the use of any patented materials, equipment, or processes.

6.07 LABOR CODE REQUIREMENTS

A. HOURS OF LABOR

1. Eight (8) hours labor constitutes a legal day's work. The Contractor shall forfeit, as penalty to the District, twenty-five dollars (\$25) for each worker employed in the execution of the Contract by the Contractor or by any Subcontractor under him for each calendar day during which such worker is required or permitted to labor more than eight (8) hours in any one (1) calendar day and forty (40) hours in one (1) calendar week in violation of the provisions of the Labor Code, and in particular, Section 1810 to Section 1815 thereof, inclusive, except that work performed by employees of Contractor in excess of eight (8) hours per day, and forty (40) hours during any one week, shall be permitted upon compensation for all hours in excess of eight (8) hours per day at not less than one and one half (1½) times the basic rate of pay, as provided in said Section 1815.

B. PREVAILING WAGE

1. The Contractor shall comply with Labor Code Sections 1774 to 1775. Pursuant to said Section 1775 the Contractor shall forfeit to the District a penalty of not more than two hundred dollars (\$200) for each calendar day or portion thereof, for each worker paid less than the general prevailing rate of wages as determined by the Department of Industrial Relations of the State of California for any work done under the Contract, by him or her, or by any Subcontractor under him or her, in violation of the provisions of the Labor Code, and in particular, Sections 1770 to 1780 thereof, inclusive.
2. The scale of prevailing wages is available at the principal office of the State's Department of Industrial Relations, Division of Labor Standards Enforcement, Bureau of Field Enforcement Office or the State's nearest local office for the County where the work is being performed. The Contractor is required to post a copy of said wage scale at the job site prior to commencement of work.

C. PAYROLL RECORDS

1. The Contractor's attention is directed to the provisions of Labor Code Section 1776. The Contractor shall be responsible compliance by his/her/their/its Subcontractors with said provisions.
2. The Contractor and Subcontractors shall keep an accurate payroll record, showing the name, address, social security number, work classification, straight time and overtime hours worked each day and week, and the actual per diem wages paid to each worker, or other employee employed by him in connection with the execution of the work.
3. The payroll records shall be certified and shall be made available for inspection at all reasonable hours at the principal office of the Contractor or Subcontractor or shall be furnished to any employee, or his/her/their/its authorized representative on request, according

to. Labor Code Section 1776. The District, State Department of Industrial Relations, and any State or Federal agency involved in the financing of the work, or any of their authorized representatives shall have access to such books, records, documents, and other evidence for the purpose of inspection, audit and copying. The Contractor will provide facilities for such access and inspection.

4. Each Contractor and Subcontractor and its Subcontractor shall submit its certified payroll record to the District (or its designated agent) on a weekly basis. If there was no work performed during the week, the certified payroll may be annotated "no work" for that week, and all contractors and subcontractors must furnish electronic certified payroll records directly to the Department of Industrial Relations.).
5. The Contractor shall maintain books, records, documents and other evidence directly pertinent to performance on work under this contract in accordance with generally accepted accounting principles and the financial information and data used by the Contractor in preparation or support of the cost submission for any negotiated contract or change order and a copy of the cost summary submitted to the District.
6. Records shall be maintained and made available during the performance of work under this contract and until ten (10) years from the date of final payment for the project. In addition, those records which relate to any dispute appeal under this contract, to litigation, to the settlement of claims arising out of such performance, or costs or items to which an audit exception has been taken shall be maintained and made available until three (3) years after the date of resolution of such appeal, litigation, claim, or exception.

D. LABOR DISCRIMINATION

1. Attention is directed to Section 1735 of the California Labor Code.
2. No discrimination shall be made in the employment of persons upon public works because of the race, religious creed, color, national origin, ancestry, physical handicap, medical condition, marital status, or sex of such persons, except as provided in Section 12940 of the Government Code, and every Contractor for public works violating this section is subject to all the penalties imposed for a violation of Chapter 1 of Part VII, in accordance with the provisions of Section 1735 of the Labor Code.

E. APPRENTICES

1. Attention is directed to the provisions in Sections 1777.5, 1777.6, and 1777.7 of the California Labor Code and Title 8, California Code of Regulations Section 200 et seq. concerning the employment of apprentices by the Contractor or any Subcontractor under him.
2. The Contractor is required to make contributions to funds established for the administration of apprenticeship programs if he employs registered apprentices or journeymen in any apprentice able trade on such contracts and if other contractors on the public works site are making such contributions.

F. WORKERS COMPENSATION

1. Pursuant to the requirements of Section 1860 of the Labor Code, the Contractor will be required to secure the payment of worker's compensation to his/her/their/its employees in accordance with the provisions of Section 3700 of the Labor Code.
2. Prior to the commencement of work, the Contractor shall sign and file with the Engineer the Certificate of Worker's Compensation contained in the Bid.

6.08 TRAFFIC CONTROL

- A. Contractor is responsible and shall comply with all applicable Federal, State, County and Local

requirements as required for traffic control and public safety during project construction. Coordination with the proper agencies and the placement and maintenance of warning signs, lights and other traffic control devices, as may be required, shall be the responsibility of the Contractor.

6.09 TRENCH EXCAVATION AND DISCOVERY OF HAZARDOUS WASTE

- A. Public Contract Code §7104 Contracts for digging trenches or excavations; notice of discovery of hazard waste or other unusual conditions; investigations; change orders; effect on contract.
- B. Any public works contract of a local public entity, which involves digging trenches or other excavations that extend deeper than four (4) feet below the surface, shall contain a clause, which provides the following:
 - 1. Contractor shall promptly, and before the following conditions are disturbed, notify the Engineer, in writing, of any:
 - a. Material that the Contractor believes may be material that is hazardous waste, as defined in Section 25117 of the Health and Safety Code that is required to be removed to a Class I, Class II, or Class III disposal site in accordance with provisions of existing law.
 - b. Subsurface or latent physical conditions at the site differing from those indicated by information about the site made available to bidders prior to the deadline for submitting bids.
 - c. Unknown physical conditions at the site of any unusual nature, different materially from those ordinarily encountered and generally recognized as inherent in work of the character provided for in the contract.
 - 2. The District shall promptly investigate the conditions, and if it finds that the conditions do materially so differ, or do involve hazardous waste, and cause a decrease or increase in the Contractor's cost of, or the time required for, performance of any part of the work shall issue a change order under the procedures described in the contract.
 - 3. In the event that a dispute arises between the District and Contractor whether the conditions materially differ, or involve hazardous waste, or cause a decrease or increase in the Contractor's cost of, or time required for, performance of any part of the work, the Contractor shall not be excused from any scheduled completion date provided for by the contract, but shall proceed with all work to be performed under the contract. The Contractor shall retain any and all rights provided either by contract or by law, which pertain to the resolution of disputes and protests between the contracting parties.
- C. Attention is also directed to the provisions of Section 6705 of the Labor Code concerning trench excavation safety plans.
- D. Prior to excavation for trenches four (4) feet or more in depth, the Contractor shall prepare detailed plans, showing the design of shoring, bracing, sloping, or other provisions to be made for worker protection from the hazard of caving ground. If the plans vary from shoring system standards established by the California Division of Industrial Safety, a civil or structural engineer currently registered in California shall prepare the plans. Nothing herein shall be deemed to allow use of shoring, sloping, or protective systems less than those required by the State standards.

6.10 AIR POLLUTION CONTROL

- A. The Contractor shall comply with all pollution control rules, regulations, ordinances, and statutes which apply to the work performed under the contract including any air pollution rules, regulation and ordinances and statutes, specified in Section 11017 of the Government Code.

- B. Unless otherwise provided in the special provisions, material to be disposed of shall not be burned.

6.11 WATER POLLUTION CONTROL

- A. The Contractor shall exercise every reasonable precaution to protect streams, lakes, reservoirs, bays, waterways, coastal waters, and other bodies of water from pollution with fuels, oils, bitumen's, calcium chloride, and other harmful materials and shall conduct and schedule his/her/their/its operations so as to avoid or minimize muddying and silting of said streams, lakes, reservoirs, bays, waterways, and coastal waters. Care shall be exercised to preserve vegetation beyond the limits of construction.
- B. Water pollution control work is intended to provide prevention, control and abatement of water pollution to streams, waterways, and other bodies of water.
- C. Nothing in the terms of the Contract shall relieve the Contractor of the responsibility for compliance with Sections 5650 and 12015 of the Fish and Game Code, or other applicable statutes relating to prevention or abatement of water pollution.

6.12 ASBESTOS RELATED WORK

All work involving asbestos containing material shall be performed in accordance with Sections 6501.5 through 6511, inclusive, of the California Labor Code and Section 5208 of Title 8 of the California Administrative Code and all other pertinent regulations.

6.13 SAFETY AND HEALTH PROVISIONS

- A. The Contractor shall conform to all applicable occupational safety and health standards, rules, regulations, and orders established by the California Division of Industrial Safety.

6.14 PUBLIC CONVENIENCE AND SAFETY

- A. The Contractor shall so conduct his/her/their/its operations as to offer the least possible obstruction and inconvenience to the public and he shall have under construction no greater amount of work than he can prosecute properly with due regard to the rights of the public.
- B. Construction operations shall be conducted in such a manner as to cause as little inconvenience as possible to abutting property owners.
- C. Whenever the Contractor's operations create a condition hazardous to traffic or the public, he shall furnish, erect, and maintain at his/her/their/its expense and without cost to the District, such fences, barricades, lights, signs and other devices as are necessary to prevent accidents or damage or injury to the public.
- D. Should the Contractor appear to be neglectful or negligent in furnishing warning and protective measures as above provided, the Engineer may direct attention to the existence of a hazard and the necessary warning and protective measures shall be furnished and installed by the Contractor at his/her/their/its expense. Should the Engineer point out the inadequacy of warning and protective measures, such action on the part of the Engineer shall not relieve the Contractor from responsibility for public safety or abrogate his/her/their/its obligation to furnish and pay for these devices.

6.15 PRESERVATION OF PROPERTY

- A. Trees, shrubs, and other plants that are not to be removed, and pole lines, fences, signs, markers and monuments, buildings and structures, conduits, pipe lines under or above ground, sewer and water lines, all street and highway facilities, and any other improvements or facilities within or

adjacent to the site of work shall be protected from injury or damage, and if ordered by the Engineer, the Contractor shall provide and install suitable safeguards, approved by the Engineer, to protect such objects from injury or damage. If such objects are injured or damaged by reason of the Contractor's operations, they shall be replaced or restored at the Contractor's expense. The facilities shall be replaced and restored to a condition as good as when the Contractor entered upon the work.

- B. The fact that any underground facility is not shown upon the plans shall not relieve the Contractor of his/her/their/its responsibility under this Section. It shall be the Contractor's responsibility to ascertain the existence of any underground improvements or facilities, which may be subject to damage by reason of his/her/their/its operations.
- C. Full compensation for furnishing all labor, materials, tools, equipment, and incidentals, and for doing all the work involved in protecting or repairing property as specified in the Section shall be considered as included in the prices paid for the various Contract items of work and no additional compensation will be allowed therefore.

6.16 RESPONSIBILITY FOR DAMAGE

- A. To the extent allowable by law the District or the Engineer shall not be answerable or accountable in any manner for any loss or damage that may happen to the work or any part thereof; or for any material or equipment used in performing the work; or for injury or death of any person or persons, either workers or the public; or for damage to property from any cause whatsoever.
- B. To the extent allowable by law the Contractor shall be responsible for any liability imposed by law and injuries to or death of any person including but not limited to workers and the public, or damage to property resulting from defects or obstructions or from any cause whatsoever during the progress of the work or at any time before final acceptance.
- C. The Contractor shall indemnify and save harmless the District and other indemnified parties and the Engineer from any suits, claims, or actions of every name, kind, and description, brought forth, or on account of any injuries to or death of any person including but not limited to workers and the public, or damage to property resulting from the performance of the contract except to the extent caused by the sole negligence or willful misconduct of the indemnified party.
- D. The District may retain so much of the money due the Contractor as shall be considered necessary, until disposition has been made of such suits or claims for damages as aforesaid.

6.17 CONTRACTOR'S RESPONSIBILITY FOR WORK

Until the formal acceptance by the District, the Contractor shall have the charge and care of the work and materials to be used therein, including work and materials for which he has received partial payment and shall bear the risk of injury, loss, or damage to any part thereof by the action of the elements or from any other cause, whether arising from the execution or from the non-execution of the work. The Contractor shall rebuild, repair, restore, and make good all injuries or damages to any portion of the work occasioned by any cause before its completion and acceptance and shall bear the expense thereof.

6.18 PERSONAL LIABILITY

The District, the Engineer, or any other officer or authorized agent shall not be personally responsible for any liability arising under or by virtue of the Contract.

6.20 ENGINEER'S RESPONSIBILITIES FOR SAFETY

It is understood and agreed that the Engineer has no constructive use of the work; has no control or authority over the means, methods and sequences of construction; and therefore has no ongoing responsibility whatsoever for construction site safety, a responsibility that has been wholly vested in the

Contractor. Notwithstanding the above, the Engineer has a duty to preserve and protect public health, safety, and welfare. It is the Engineer's professional responsibility to take what the Engineer believes is prudent measures should the Engineer encounter situations that the Engineer believes create danger to the public health, safety or welfare. The Contractor understands this situation and agrees to defend and hold the Engineer harmless from claims arising from the Engineer's exercise of professional responsibility in this regard.

6.21 RESPONSIBILITY OF DISTRICT

The District shall not be held responsible for the care or protection of any materials or parts of the work prior to final acceptance, except as expressly provided in these specifications.

SECTION 7 - PROSECUTION AND PROGRESS

7.01 SUBLETTING AND ASSIGNMENT

- A. The Contractor shall give his/her/their/its personal attention to the fulfillment of the Contract and shall keep the work under his/her/their/its control.
- B. No Subcontractors will be recognized as such, and all persons engaged in the work of construction will be considered as employees of the Contractor, and he will be responsible for their work, which shall be subject to the provisions of the Contract and Specifications.
- C. The Contractor shall perform with his/her/their/its own organization contract work amounting to not less than twenty percent (20%) of the original total contract price.
- D. Subcontracts shall include provisions that the contract between the District and the Contractor is part of the subcontract, and that the terms and provisions of said contract are incorporated into the subcontract. Subcontracts shall also contain certification by the subcontractor that said subcontractor is experienced in and qualified to do, and knowledgeable about, the subcontract work. Copies of subcontracts shall be available for review by the Engineer
- E. When any portion of the work, which has been subcontracted by the Contractor, is not being prosecuted in a manner satisfactory to the Engineer, the subcontractor shall be removed immediately on the request of the Engineer and shall not again be employed on the work.

7.02 ASSIGNMENT

The performance of the contract may not be assigned, except upon written consent of the Engineer. Consent will not be given to any proposed assignment, which would relieve the original, Contractor or his/her/their/its surety of their responsibilities under the contract.

7.03 PROGRESS OF THE WORK

- A. The Contractor shall commence work within thirty (30) days after the date of the written Notice to Proceed from the Engineer, unless otherwise set forth in the Special Provisions. The Contractor shall diligently prosecute the work to completion within the time limit set forth in the Special Provisions.
- B. The Contractor shall provide the Engineer with a work plan and schedule in accordance with the Specifications. The Contractor shall promptly notify the Engineer of any changes or delays in the prosecution and progress of the work.

7.04 TEMPORARY SUSPENSION OF WORK

The Engineer shall have the authority to suspend the work wholly or in part, for such period as he may deem necessary, due to unsuitable weather, or to such other conditions as are considered unfavorable for the suitable prosecution of the work, or for such time as he may deem necessary, due to the failure on the part of the Contractor to carry out orders given, or to perform any provision of the contract. The Contractor shall immediately comply with the written order of the Engineer to suspend the work wholly or in part. The suspended

work shall be resumed when conditions are favorable and methods are corrected, as ordered in writing by the Engineer.

7.05 TIME OF COMPLETION

- A. The Contractor shall complete all or any designated portion of the work called for under the contract in all parts and requirements within the time set forth in the Special Provisions.
- B. Should the Contractor prepare to begin work at the regular starting time of any day on which "abnormally severe" inclement weather, or conditions resulting there from, or the conditions of the work, prevents the work from beginning at the usual starting time and the crew is dismissed as a result thereof and the Contractor does not proceed with at least seventy-five percent (75%) of the normal labor and equipment force in the current controlling operation(s) for at least sixty percent (60%) of the total daily time being spent on the controlling operation(s), the Contractor will not be charged for a working day whether or not the conditions should change thereafter during said day.
- C. The current controlling operation(s) is to be construed to include any feature of the work, operation, or activity considered at the time by the Engineer and the Contractor, which, if delayed or prolonged, will delay the time of completion of the contract.
- D. Determination that a day is a non-working day by reason of inclement weather or conditions resulting there from, shall be made by the Engineer, provided that the Contractor shall notify the Engineer in writing of the causes of delay within seven (7) days from the beginning of any such delay.

7.06 LIQUIDATED DAMAGES

- A. It is agreed by the parties to the Contract that in the event that all the work called for under the Contract in all parts and requirements is not finished or completed within the number of days set forth in the Special Provisions, or as may be adjusted by the Engineer, damage will be sustained by the District, and that it is and will be impracticable and extremely difficult to ascertain and determine the actual damage which the District will sustain in the event of and by reason of such delay. It is therefore agreed that the Contractor will pay to the District the sum set forth in the **Special Provisions** per day for each and every calendar day's delay in finishing the work in excess of the number of days prescribed; and the Contractor agrees to pay said liquidated damages as herein provided for, and further agrees that the District may deduct the amount thereof from any moneys due or that may become due the Contractor under the Contract.
- B. It is further agreed that in case the work called for under the Contract is not finished and completed in all parts and requirements within the number of days specified, the Engineer shall have the right to increase the number of days, or not, as he may deem best to serve the interest of the District, and if he decides to increase the number of days, he shall further have the right to charge the Contractor, his/her/their/its heirs, assigns, or sureties, and to deduct from the final payment for the work all or part, as it may deem proper, of the actual cost of engineering, inspection, superintendence, and other overhead expenses which are directly chargeable to the Contract, and which accrue during the period of such extension, except that the cost of final surveys and preparation of final estimate shall not be included in such charges.

- C. The Contractor will be granted an extension of the time and will not be assessed with liquidated damages or the cost of engineering and inspection for any portion of delay in the completion of the work beyond the time named in the special provisions for the completion of the work caused by acts of God, or of the public enemy, acts of the District, fire, floods, tidal waves, earthquakes, epidemics, quarantine restrictions, strikes, labor disputes, shortage of materials, freight embargoes, provided that the Contractor shall notify the Engineer in writing of the causes of delay within ten (10) days from the beginning of any such delay. The Engineer shall ascertain the facts and the extent of delay, and his/her/their findings thereon shall be final and conclusive.

7.07 SUSPENSION OF CONTRACT

- A. If at any time in the opinion of the District, the Contractor has failed to supply an adequate working force, or material of proper quality, or has failed in any other respect to prosecute the work with the diligence and force specified and intended in and by the terms of the contract, notice thereof in writing will be served upon him and should he neglect or refuse to provide means for a satisfactory compliance with the contract, as directed by the Engineer, within the time specified in such notice, the District in any such case shall have the right to suspend the operation of the contract. Upon receiving notice of such suspension, the Contractor shall discontinue said work, or such parts of it as the District may designate. Upon such

suspension, the Contractor's control shall terminate, and thereupon the District or his/her/their/its duly authorized representative may take possession of all or any part of the Contractor's materials, tools, equipment, and appliances upon the premises, and use the same for the purpose of completing said contract, and hire such force and buy or rent such additional machinery, tools, appliances and equipment, and buy such additional materials and supplies at the Contractor's expense as may be necessary for the proper conduct of the work and for the completion thereof; or may employ other parties to carry the contract to completion, employ the necessary workers, substitute other machinery or materials, and purchase the materials contracted for, in such manner as the District may deem proper; or the District may annul and cancel the contract and re-let the work or any part thereof. Any excess of cost arising there from over and above the contract price will be charged against the Contractor and his/her/their/its sureties, who will be liable therefore. In the event of such suspension, all monies due the Contractor or retained under the terms of this contract shall be withheld and available to the District but such withholding will not release the Contractor or his/her/their/its sureties from liability or failure to fulfill the contract. The Contractor and his/her/their/its sureties will be credited with the amount of money so withheld toward suspension of the operations of the Contract and the completion of the work by the District as above provided, and the Contractor will be so credited with any surplus remaining after all just claims for such completion have been paid.

- B. In the determination of the question whether there has been any such non-compliance with the contract as to warrant the suspension or annulment thereof, the decision of the District shall be binding on all parties to the Contract.

SECTION 8 - MEASUREMENT AND PAYMENT

8.01 MEASUREMENT OF QUANTITIES

Items for which quantities are indicated "Lump Sum" shall be paid for at the price indicated in the Bid. Such payment shall be full compensation for the items of work and all work appurtenant thereto. The quantities given in the plan sheets and or contract are being given as a basis for the comparison of bids.

8.02 EXTRA WORK

- A. New and unforeseen work will be classified as extra work when determined by the Engineer that such work is not covered by any of the various items for which there is a bid price or by combinations of such items.

- B. The Contractor shall do such extra work and furnish labor, materials, and equipment therefore upon receipt of an approved Contract Change Order or other written order of the Engineer and in the absence of such approved Contract Change Order or other written order of the Engineer, the Contractor shall not be entitled to payment for such extra work.
- C. When extra work is to be paid for on a lump sum basis, the amount of said payment shall be agreed upon in writing prior to execution of the work. Lump sum payments shall be considered full compensation for the items of work and all appurtenances thereto.
- D. When extra work is to be paid for on a cost and percentage basis, the labor, materials, and equipment used in the performance of such work shall be subject to the approval of the Engineer and compensation will be determined as follows:
1. Labor - The Contractor shall receive the cost of all labor of any class, including foremen, engaged in the extra work, plus an amount equal to twenty-five percent (25%) of the sum thereof.
 2. The costs of labor shall be based on the State of California Department of Industrial Relations Prevailing Wage Determination in effect at the date the contract was executed. Said costs shall include the basic hourly rate, health and welfare, pension, vacation and holiday, and training funds. Employer payments of payroll taxes, social security, Medicare, federal unemployment, state unemployment, state training taxes, workers compensation insurance, liability insurance, and other direct costs, resulting from Federal, State, or local laws are considered part of the percentage amount.
 3. The use of a labor classification, which would increase the extra work cost, will not be permitted unless the Contractor establishes the necessity for such additional costs. Labor costs for equipment operators and helpers shall be reported only when such costs are not included in the invoice for equipment rental. The labor cost for foremen shall be proportioned to all of their assigned work and only that applicable to extra work will be paid.
 4. Materials - The Contractor will receive the cost of all materials which he purchase and uses in the extra work, plus an amount equal to fifteen percent (15%) of the sum thereof. The cost of all materials shall include freight charges and taxes as shown by original invoiced bills for said materials.
 5. The District reserves the right to furnish such materials required as it deems expedient, and the Contractor shall have no claim for profit on the cost of such materials.
 6. If the extra work requires the use of equipment not originally contemplated by the Contractor when submitting its Bid, the Contractor will be paid for the use of equipment at the rental rates listed for such equipment in the State Department of Transportation publication entitled Labor Surcharge and Equipment Rental Rates, which was in effect on the date the contract for the work was executed.
 7. The rental rates paid shall include the cost of fuel, oil, lubricants, supplies, small tools, necessary attachments, repairs, and maintenance of any kind, depreciation, storage, insurance, loading and transportation to the site of work, and all incidentals.
 8. All cost and percentage work shall be adjusted daily upon work sheets, prepared by the Engineer, furnished to the Contractor and signed by both parties, which daily reports shall thereafter be considered the true record of extra work done.
 9. Vendors' invoices for materials, equipment rental, and other expenditures, and certified payrolls shall be submitted with the request for payment. If the request for payment is not substantiated by the documentation enumerated above, the request will not be honored.

8.03 CHANGE ORDERS

- A. The plans, specifications, special provisions, and the contract documents contain the requirements for the construction of the project. No information obtained from any officer, agent, or employee of the District on any such matters shall in any way affect the risk or obligations assumed by the Contractor or relieve him from fulfilling any of the conditions of the contract.
- B. The Engineer may order changes, including revisions, to plans and specifications, performance of extra work, increases or decreases in contracted items of work, and the elimination of work. Such orders will be in writing. Changes shall not affect the obligations of the sureties on the contract bonds nor require their consent. The Contractor shall promptly notify the Engineer whenever it appears that a change is necessary, and when so directed, shall stop work in the areas that may be affected. Contract time and compensation will be adjusted for changes, which materially increase or decrease the time for performance or cost.
- C. When so directed, the Contractor shall proceed with changes before agreement is reached on contract adjustments to compensation or time of performance, and shall furnish to the Engineer at the end of each day, signed detailed hourly records for that day of labor, construction equipment and itemized records of materials, equipment and services used in performance of the changes. If the Contractor fails to provide such records, the Engineer's records will be used for the purpose of adjusting compensation or time of performance.
- D. When applicable, changes in contract price resulting from extra work may be determined by a mutually agreed upon lump sum price. The Contractor's Bid for such changes shall include a detailed breakdown of labor and materials to be performed by his/her/their/its forces or the forces of his/her/their/its subcontractor or material supplier. The breakdown shall include labor surcharge and sales tax cost. Whenever the District requests that the Contractor prepare a lump sum price in connection with the change order, the Contractor shall be entitled to the costs incurred in the preparation of that price. Such costs will be incorporated into the lump sum amount regardless of whether or not the lump sum amount is finally accepted by the District.
- E. The Engineer shall receive the Contractor's Bid for lump sum change orders within ten (10) days following the issuance of the change order price request.

8.04 OMITTED WORK

The District may, by written order to the Contractor, omit work, equipment, and material to be provided under the Contract, and the value of the omitted work, equipment, and material will be deducted from the contract price. The deducted value will be a lump sum or unit price agreed upon in writing by the Contractor and the District based on breakdown and cost information submitted by the Contractor.

8.05 STOP PAYMENT NOTICES

The District, through the Engineer or other appropriate District representative, may at its option and at any time, retain out of any amounts due the Contractor, sums sufficient to cover claims, filed pursuant to Section 3179 et seq. of the Civil Code. Stop Notices shall comply with the provisions of Sections 3098, 3103 and 3183 of the Civil Code of the State of California.

8.06 BID ITEMS

- A. Bid items shall be for the complete work as indicated on the plans and described in the specifications, and shall include all labor, materials, tools, transportation, supplies, equipment, appurtenances, fuel, and power, taxes, profit, and anything else necessary or required, unless specifically excepted, for the construction and adjustments of appurtenant facilities in a workmanlike manner.
- B. Payments will be made on the basis of the items listed on the Bid and no additional claims for compensation will be allowed therefore.

8.07 PARTIAL PAYMENTS

- A. Once each month the Contractor may submit to Engineer a payment request showing the total amount of work done and the amount requested. The related delivery or weight tags shall accompany such payment request, payroll certificates, lien releases and any other documentation required to substantiate completion of the work.
- B. The Engineer for partial payment purposes shall determine the value of the work completed. The Engineer may require the Contractor to submit a monthly statement indicating the status of completion of each item of work and accompanied by such documentation as be required to substantiate the completion of work.
- C. The District will retain five percent (5%) from such estimated value of work done and materials furnished as retention earnings and the remainder, less the amount of all previous payments, will be paid to the Contractor. After final completion and acceptance of the work done under this Contract, if unencumbered, the District shall release and pay the amount retained under the provisions of the Section entitled "Final Payment". The District has the option and may release fifty percent (50%) of the retention withheld, if unencumbered, on the last Progress Payment Estimate of the work satisfactorily completed and accepted.
- D. No progress payment made to the Contractor or its sureties will constitute a waiver of liquidated damages.
- E. As provided for in Section 22300 of the California Public Contract Code, the Contractor may substitute securities for any monies withheld by the District to ensure performance under the contract.
- F. Public Contract Code Section §20104.50 is applicable to this contract and provides as follows:
 - 1. §20104.50 timely progress payments, legislative intent; interest; payment requests
 - a. It is the intent of the Legislature in enacting this section to require all local governments to pay their contractors on time so that these Contractors can meet their own obligations. In requiring prompt payment by all local governments, the Legislature hereby finds and declares that the prompt payment of outstanding receipts is not merely a municipal affair, but is instead, a matter of statewide concern.
 - b. It is the intent of the legislature in enacting this article to fully occupy the field of public policy relating to the prompt payment of local governments' outstanding receipts. The Legislature finds and declares that all government officials, including those in local government, must set a standard of prompt payment that any business in the private sector, which may contract for services, should look towards for guidance.
 - 2. Any local agency which fails to make any progress payment within thirty (30) days after receipt of an undisputed and properly submitted payment request from a Contractor on a construction contract shall pay interest to the Contractor equivalent to the legal rate set forth in subdivision (a) of Section 685.010 of the Code of Civil Procedure.
 - 3. Upon receipt of a payment request, each local agency shall act in accordance with both of the following:
 - a. Each payment request shall be reviewed by the local agency as soon as practicable after receipt for the purpose of determining that the payment request is a proper payment request.
 - b. Any payment request determined not to be a proper payment request suitable for payment shall be returned to the Contractor as soon as practicable, but not later than seven (7) days, after receipt. A request returned pursuant to this paragraph shall be accompanied by a document setting forth in writing the reasons why the payment request is not proper.

4. The number of days available to a local agency to make a payment without incurring interest pursuant to this section shall be reduced by the number of days by which a local agency exceeds the seven (7) day return requirement set forth in paragraph (2) of subdivision (c).
5. For purposes of this article:
 - a. A "local agency" includes, but is not limited to, a city, including a charter city, a county, and a city and county, and is any public entity subject to this part.
 - b. A "progress payment" includes all payments due Contractors, except that portion of the final payment designated by the contract as retention earnings.
 - c. A payment request shall be considered properly executed if funds are available for payment of the payment request, and the financial officer of the local agency does not delay payment due to an audit inquiry.

8.08 FINAL PAYMENT

- A. After the completion and acceptance of the work by the District, the Engineer will make a final estimate of the amount of work done there under, and the value of such work, and the District shall pay the entire sum so found to be due after deducting there from all previous payments and all amounts to be kept and all amounts to be retained under the provisions of the Contract. All prior partial estimates and payments shall be subject to correction in the final estimate and payment.
- B. Within sixty (60) days after the date of completion of the work of improvement, the retention withheld by the public entity shall be released. In the event of a dispute between the public entities may withhold from the final payment an amount not to exceed one hundred fifty percent (150%) of the disputed amount. For purposes of this subdivision, "completion" means any of the following:
 1. The occupation, beneficial use, and enjoyment of a work of improvement, excluding any operation only for testing, startup, or commissioning, by the public agency, or its agent, accompanied by cessation of labor on the work of improvement.
 2. The acceptance by the public agency, or its agent, of the work of improvement.
 3. After the commencement of work of improvement, a cessation of labor on the work of improvement of continuous period of one hundred (100) days or more, due to factors beyond the control of the Contractor.
 4. After the commencement of work of improvement, a cessation of labor on the work of improvement for a continuous period of thirty (30) days or more, if the public agency files for record a notice of cessation or a Notice of Completion.
- C. Work will not be considered complete in areas where a certificate of approval from the County, State or other regulatory agency is required until said certificate is received by the District.
- D. It is mutually agreed between the parties to the Contract that no certificates given or payments made under the Contract, except the final certificate or final payment, shall be conclusive evidence of the performance of the Contract, either wholly or in part, against any claim of the party of the first part, and no payment shall be construed to be an acceptance of any defective work or improper materials
- E. The Contractor further agrees that the payment of the final amount due under the contract, and the adjustment and payment for any work done in accordance with any alterations of the same, shall release the District and the Engineer from any and all claims or liability on account of work performed under the contract or any alteration thereof.

8.09 RESOLUTION OF CONTRACT CLAIMS

- A. Provisions of Section 20104 (b) (2) State that a “claim” means a separate demand by the Contractor for (A) a time extension, (B) payment of money or damages arising from work done by, or on behalf of, the Contractor pursuant to the contract for a public work and payment of which is not otherwise expressly provided for or the claimant is not otherwise entitled to, or (C) an amount the payment of which is disputed by the local agency.
- B. Public Contract Code Section 20104 and other sections in Article 1.5 apply to all public works claims of three hundred seventy-five thousand dollars (\$375,000) or less which arise between a Contractor and a local agency.
- C. For any claim subject to this article, the following requirements apply:
 - 1. The claim shall be in writing and include the documents necessary to substantiate the claim. Claims must be filed on or before the date of final payment. Nothing in this subdivision is intended to extend the time limit or supersede notice requirements otherwise provided by contract for the filing of claims.
 - a. For claims of less than fifty thousand dollars (\$50,000), the District shall respond in writing to any written claim within forty-five (45) days of receipt of the claim, or may request, in writing, within thirty (30) days of receipt of the claim, any additional documentation supporting the claim or relating to defenses to the claim the District may have against the claimant.
 - 1. If additional information is thereafter required, it shall be requested and provided pursuant to this subdivision, upon mutual agreement of the District and the claimant.
 - 2. The District's written response to the claim, as further documented, shall be submitted to the claimant within fifteen (15) days after receipt of the further documentation or within a period of time no greater than that taken by the claimant in producing the additional information, whichever is greater.
 - b. For claims of over fifty thousand dollars (\$50,000) and less than or equal to three hundred seventy-five thousand dollars (\$375,000), the District shall respond in writing to all written claims within sixty (60) days of receipt of the claim, or may request, in writing, within thirty (30) days of receipt of the claim, any additional documentation supporting the claim or relating to defenses to the claim the District may have against the claimant.
 - 1. If additional information is thereafter required, it shall be requested and provided pursuant to this subdivision, upon mutual agreement of the District and the claimant.
 - 2. The District's written response to the claim, as further documented, shall be submitted to the claimant within thirty (30) days after receipt of the further documentation, or within a period of time no greater than that taken by the claimant in producing the additional information or requested documentation, whichever is greater.

8.10 ADJUSTMENT OF DISPUTE

- A. All questions or controversies which may arise between the Contractor and the District, under or in reference to this contract, shall be subject to the decision of some competent person to be agreed upon by the District and the Contractor, and his/her/their/its decisions shall be final and conclusive upon both parties.
- B. Should the District and Contractor be unable to agree upon such person, a board of three (3) arbitrators shall be chosen, one (1) by the District, one (1) by the Contractor, and the third (3rd) by

the two (2) so chosen, and the decision of any two (2) of said arbitrators shall be final and binding upon the parties. If either party to the Contract neglects or fails for a period often (10) days after notice from the other party to designate an arbitrator hereunder, the arbitrator designated by the other party shall have full power to decide the dispute in the same manner as though a board of three (3) arbitrators had been selected. The referee or arbitrators shall decide which party shall pay the cost of arbitration, and final payment to the Contractor shall not be made until the full decision of the referee or arbitrators has been rendered.

END OF DOCUMENT 00401

**DOCUMENT 00402
SPECIAL PROVISIONS**

1.01 DESCRIPTION OF WORK

The work to be performed shall consist of furnishing all labor, materials, tools, transportation, supplies, equipment, appurtenances, fuel, and power, and incidentals, and for doing all the work necessary or required for the construction and adjustments of appurtenant facilities on the project site as shown or noted on the plans.

1.02 QUANTITIES

- A. The Engineer's preliminary estimate of the quantities of work to be done and the materials to be furnished are indicated on the form of proposal and are approximate only, being given as a basis for comparison of bids. The District does not expressly or by implication agree that the actual amount of work will correspond therewith. The District reserves the right to increase or decrease the quantities of work or materials to be furnished in accordance with the provisions of the General Conditions.
- B. The District also reserves the right to increase or decrease the total amount and quantity of work required under the Contract from the total amount indicated in the accepted bid proposal by twenty-five percent (25%) in the absence of an executed change order at the contract unit prices.

1.03 PROGRESS OF WORK AND TIME FOR COMPLETION

After the District has approved and signed the contract, the Engineer will issue the Notice to Proceed. The Contractor shall commence work within seven (7) days after the date of the written Notice to Proceed and shall diligently prosecute the work to completion within thirty (30) days of commencement of work, with the exception of asphalt pavement coating. Asphalt pavement coating shall be completed within 75 calendar days from the date of Notice to Proceed. **See also 1.12 below.**

1.04 LIQUIDATED DAMAGES

- A. In accordance with Section 7.06 of the General Conditions, an amount of **\$1,000.00** per day for each and every calendar day (including Saturdays and Sundays) of delay beyond the **30 calendar days** prescribed to complete the work will be deducted from any moneys due or which may become due the Contractor. **See also 1.12 below.**
- B. All work, **with the exception of asphalt pavement coating**, shall be completed within the **30 calendar days** specified above.
- C. Asphalt pavement coating shall be completed within **75 calendar days** from the date of Notice to Proceed. This extended duration is provided to allow newly placed asphalt concrete to cure a minimum of **30 days** prior to application of asphalt pavement coating.
- D. Construction activities shall not be permitted on the 2nd and 4th Tuesday of each month due to scheduled Board meetings. These days shall not be counted toward the contract time or for assessment of liquidated damages.

1.05 CONTRACTOR'S GUARANTY

The Contractor shall and hereby does guarantee the Work for a period of three (3) years after the date of acceptance of the work by the District. The Contractor shall repair or remove and replace any and all such work, together with any other work which may be displaced in so doing, that is found to be defective in workmanship and/or materials within said three (3) year period, without expense whatsoever to the District, ordinary wear and tear and unusual abuse or neglect excepted. In the event of a failure to

comply with the above-mentioned conditions within seven (7) days after being notified in writing, the District is hereby authorized to proceed to have the defects remedied and made good at the expense of the Contractor who hereby agrees to pay the cost and charges therefore immediately on demand. Such action by the District will not relieve the Contractor of the guarantees required by this article or elsewhere in the Contract Documents.

Prior to final payment under the contract, the Contractor shall furnish a maintenance warranty bond in the penal sum of ten percent (10%) of the total original contract price, to assure performance of the Contractor's obligations under this paragraph after the expiration of the obligation under the Performance Bond, for the remainder of the maintenance warranty period.

If, in the opinion of the District, defective work creates a dangerous condition or requires immediate correction or attention to prevent further loss to the District or to prevent interruption of operations of the District, the District will attempt to give the notice required by this article. If the Contractor cannot be contacted or does not comply with the District's request for correction within a reasonable time as determined by the District, the District may, notwithstanding the provisions of this article, proceed to make such correction or provide such attention; the costs of such correction or attention shall be charged against the Contractor. Such action by the District will not relieve the Contractor of the guarantees required by this article or elsewhere in the Contract Documents.

This article does not in any way limit the guarantee on any items for which a longer guarantee is specified or on any items for which a manufacturer or supplier gives a guarantee for a longer period. The Contractor agrees to act as a co-guarantor with such manufacturer or supplier and shall furnish the District all appropriate guarantee or warranty certificates upon completion of the project. No guarantee period, whether provided for in this article or elsewhere, shall in any way limit the liability of Contractor or his/her/their/its sureties or insurers under the indemnity or insurance provisions of these General Provisions.

1.06 PRE-CONSTRUCTION CONFERENCE

The Engineer will schedule a pre-construction conference with the CONTRACTOR after the Notice of Contract Award. Contractor and Subcontractor representatives shall attend.

1.07 PROJECT MEETINGS

- A. Meetings may be held if and as often as deemed necessary by the Engineer or requested by the Contractor. Representatives of the Engineer and CONTRACTOR shall attend.
- B. The purpose of the meetings will be to discuss compliance with the contract plans, progress, coordination, submittals, and project-related problems and changes.

1.08 PRE-CONSTRUCTION INSPECTION

- A. Prior to the commencement of work, a joint inspection between the Engineer or his/her/their/its representative, and the Contractor or his/her/their/its representative may be conducted to review the pre-construction conditions of the existing facilities in the vicinity of the project site, (e.g. roads, pumps, discharge pipes, siphons, ramps, gates, signs, etc.).
- B. If such existing facilities are damaged by the Contractor's operations, the Contractor, at his/her/their/its expense, shall replace or restore them to the condition that existed prior to the commencement of work.
- C. The Contractor shall notify the District at (209) 249-4647 a minimum of 48 hours prior to the commencement of any work.

1.10 RESPONSIBILITY FOR WORK

Contractor agrees that he/she/they/it shall assume sole and complete responsibility for job site

conditions during the course of construction of this project, including safety of all persons and property: that this requirement shall apply continuously and not be limited to normal working hours; and that the Contractor shall defend, indemnify, and hold the District and the Engineer harmless from any and all liability, real or alleged in connection with the performance of Work on this project, excepting for liability arising from the sole negligence of the District or the Engineer.

1.11 LEGAL RELATIONS AND SECURITY

- A. The Contractor shall comply with all applicable Federal, State, County and local requirements, as required for traffic control and public safety during project construction.
- B. The Contractor shall be responsible for providing security measures to prevent unauthorized entrance, vandalism, and theft of equipment, and materials from the work site. Any loss suffered shall be the Contractor's sole responsibility. The District shall not have any responsibility whatsoever for missing or damaged equipment, tools, or personal belongings.

1.12 SCHEDULE

Contractor shall submit preliminary work schedule within seven (7) days following signed contract. Schedule shall provide sufficient detail to show timing of construction of the individual bid items and be in the form of simple Gantt chart sufficiently scheduling items to show completion of project within timeframes stipulated in these Special Provisions

1.13 DUST AND MUD CONTROL

During the course of construction, the Contractor is responsible for dust control and shall keep all areas generating dust, well watered along the access roads used. During wet conditions, those areas also used by the public and local traffic, free and clear from mud.

1.14 SITE DATA

The approximate locations of any known utilities shown on the plans are for the information only. Neither the District nor Engineer assumes any responsibility for the accuracy, reliability of location of this information. It is the responsibility of the Contractor to determine the actual location of all underground, surface, overhead, and submerged improvements, or facilities, which may be subject to damage by reason of his/her/their/its operations.

- A. The Contractor shall be responsible for the location and preservation of all existing and such facilities in the area of construction. The Contractor shall call Underground Service Alert (USA) at (800) 642-2444, or 811 in advance of any construction.
- B. Extreme care shall be used while working around or near any structures: e.g., buildings, existing sanitary sewer lines, etc.

1.15 FIELD ENGINEERING

- A. The Plans identify locations of the various designated work requirements, within the immediate vicinity of the project site. The Contractor is responsible to perform the work to the satisfaction of the District and to perform his/her/their/its own field engineering required to perform the Work.
- B. The Contractor is responsible for setting all construction control, as required for construction activities in performing the Work.
- C. Actual field conditions may vary in type of work required for each location. The Contractor is responsible for verifying actual conditions, grades and elevations.

1.16 FINAL INSPECTION

Any deficiencies noted during interim and final inspections by the Engineer and/or District shall be

corrected by the Contractor prior to final acceptance by the District. Any additional costs and expenses for mobilization and/or demobilization, labor, equipment and other associated costs required to correct the deficiencies noted, except specified material(s), shall be borne by the Contractor.

1.18 SITE ENVIRONMENT

- A. Throughout all phases of construction, including suspension of work, and until final acceptance of the project, the Contractor shall keep the work site conditions clean and free from rubbish and debris.
- B. Materials and equipment shall be removed from the site as soon as they are no longer necessary, and upon completion of the work and before final inspection, the entire work site shall be cleared of equipment, unused materials, and rubbish so as to present a satisfactorily clean and neat appearance. All cleanup costs shall be included in the Contractor's prices for the various Contract items and no additional or separate compensation will be made.
- C. Failure by the Contractor to comply with the Engineer's cleanup orders may result in an order to suspend work until the condition is corrected. No additional compensation will be allowed as a result of such suspension.

1.19 PROTECTION OF PLANTS, TREES, CROPS, AND LANDSCAPING

The Contractor shall provide adequate protection of existing trees and plants to protect against damage from construction operations and employ protective measures at the District's discretion. No permanent crop or landscaping shall be disturbed or removed without prior approval of the Engineer.

1.20 EXTRA WORK BY SUBCONTRACTORS

- A. When a Subcontractor performs all or any part of the extra work, the markup of such work is considered a part of the percentages allowed the Prime Contractor, in Section 8.02, Extra Work, of the General Conditions.
- B. No extra markup compensation shall be allowed to the Contractor thereof.
- C. When extra work is to be performed by the Subcontractor, all such work shall be approved in writing by the Engineer and compensation based upon actual invoiced costs incurred by the Contractor.

1.21 INELIGIBLE AND DISBARRED SUBCONTRACTORS

Under California Public Contract Code, Section 6109, "Ineligible and Debarred Subcontractors", the Contractor is prohibited from performing work on a public works project with a Subcontractor who is ineligible to perform work on the public works project pursuant to Section 1777.1 or 1777.7 of the California Labor Code

1.22 SOUND CONTROL REQUIREMENTS

- A. The Contractor shall comply with all local sound control and noise level rules, regulations, and ordinances, which apply to any work performed pursuant to the contract.
- B. Each internal combustion engine, used for any purpose on the job or related to the job, shall be equipped with a muffler of a type recommended by the manufacturer. No internal combustion engine shall be operated on the project without said muffler.

1.23 CONTROL OF SITE

The Contractor shall ensure that no alcohol, firearm, or controlled substance enters or is used at the Project site. The Contractor shall immediately remove from the site and terminate the employment of

any employee found in violation of this provision.

1.24 AS-BUILT / RECORD DRAWINGS

During the progress of the work, the Contractor shall keep on the site one (1) set of prints of the drawings on which he shall mark in red all changes made necessary by structural or other interferences or changes in location of planned work. "As Built" drawings must be submitted to District in electronic format prior to District's acceptance of Work.

1.25 DOCUMENTATION AND ACCESS TO RECORDS

- A. The Contractor shall maintain books, records, documents, and other evidence directly pertinent to performance on State grant work under this contract in accordance with generally accepted accounting principles and the financial information and data used by the Contractor in preparation or support of the cost submission for any negotiated contract or change order and a copy of the cost summary submitted to the District. The, the District, or any of their authorized representatives shall have access to such books, records, documents, and other evidence for the purpose of inspection, audit, and copying. The Contractor will provide facilities for such access and inspection.
- B. Records shall be maintained and made available during performance on work under this contract and until ten (10) years from the date of final payment for the project. In addition, those records which relate to any Dispute appeal under this contract, to litigation, to the settlement of claims arising out of such performance, or costs or items to which an audit exception has been taken shall be maintained and made available until three (3) years after the date of resolution of such appeal, litigation, claim, or exception.

1.26 SUBMITTAL OF MONTHLY AND FINAL PROGRESS PAYMENT STATEMENTS

- A. The Contractor shall submit a written invoice statement to the Engineer monthly; covering the work completed and accompanied by such supporting documentation as is required for payment purposes. The statement will be based on work performed and agreed to by the established monthly closure date.
- B. The invoiced statement shall be addressed to:

**South San Joaquin Irrigation District
P.O. Box 747
Ripon, California 95366-0747
Attn: Accounts Payable**

END OF DOCUMENT 00402

**DOCUMENT 00501
GENERAL CONSTRUCTION NOTES**

The following apply to all work within South San Joaquin Irrigation District property, right-of-way, or easements and all work on South San Joaquin Irrigation District facilities, irrigation pipelines and canals:

1. Used materials, rejects, misfits, or seconds, etc. are not acceptable for use on District facilities.
2. South San Joaquin Irrigation District shall inspect all work phases on irrigation facilities for conformance to District specifications. Reinforcing shall not be encased in concrete without prior District inspection. Likewise, concrete shall not be covered with earth prior to District inspection.
3. District shall be provided with name, address, and phone number of contractors, subcontractors, etc. responsible for work being performed on District facilities. Contractor shall provide District with the name and cell phone number of contact person responsible for overseeing all phases of construction.
4. The Contractor hereby agrees to make at his/her/their/its own expense, all repairs or replacements necessitated by defects in materials or workmanship, supplied for District facilities, and pay for any damage to other works resulting from such defects which become evident within three (3) years the date of final acceptance of work. The contractor further agrees to hold the District harmless from liability of any kind arising from damage due to said defects. The contractor shall make all repairs and replacements promptly upon written order from the District.
5. The contractor will be responsible for the repairs of all concrete cracks which develop during construction of improvements affecting the Work.
6. Contractor shall adhere to all applicable standards specified within the latest revision of the District's standard plans and specifications, which can be obtained from the Engineering Department at SSJID located at 11011 E. Hwy. 120, Manteca, CA 95336. Contractor shall immediately contact the District's Engineering Department to verify any perceived discrepancies between these Plans and District Specifications.
10. The District has survey monuments on many of its existing structures. Prior to demolition of any box or structure, Contractor shall obtain existing survey monument coordinate data (if available) for possible transfer to new structures. Upon installation of any new pipeline, new monuments shall be set at each new manhole or structure. Horizontal data shall be based upon the North American Datum of 1983 (NAD83), California Coordinate System, Zone 3, US feet. Vertical datum shall be the National Geodetic Vertical Datum of 1929 (NGVD29). New coordinate data shall then be provided to District with the as-built drawings.
11. As-Built (record drawings) must be submitted to District in electronic format prior to acceptance of work shown on plans.

END OF DOCUMENT 00501

DOCUMENT 00502

SUMMARY OF WORK AND SPECIAL CONSIDERATIONS

1.01 WORK COVERED BY CONTRACT DOCUMENTS

- A. The Work covered by these Contract Documents consists generally of providing

c

Full-depth removal and replacement of approximately 19,315 square feet of asphalt concrete pavement, including subgrade preparation, compaction, placement of aggregate base, and placement of 3/4-inch Type A Hot Mix Asphalt (HMA). Removed materials shall be stockpiled at a designated on-site location. Additional work includes removal and replacement of striping and wheel stops; removal and replacement of approximately 730 square feet of 8-inch-thick reinforced concrete; application of asphalt pavement coating to approximately 2,975 square yards of existing pavement; and removal and replacement of approximately 128 linear feet of 6-inch storm drain pipe and 148 linear feet of 12-inch storm drain pipe. Work also includes temporary access, traffic control, coordination to maintain District operations, and implementation of water pollution control measures. The Contractor shall coordinate all work with District staff to maintain access and minimize disruption to District operations.

- B. Each item in the Bid Schedule is described below and shall be installed per standard SSJID specifications.

1. **Mobilization & Demobilization, Insurance, & Bonding (LS):** Payment for this item shall include full compensation for all labor materials, tools, equipment, and incidentals making up the cost of mobilization, move-in, move-out, all necessary bonds, insurance permits, licenses, and fees required during the performance of the work as specified. This item also includes demobilization, including the removal of all equipment, supplies, and personnel and incidentals from the project at the end of construction. Payment for mobilization shall be made with the first progress payment and shall not exceed 80% of bid item amount. Payment for demobilization shall be made with the last progress payment and shall not be less than 20 percent of the bid item amount.
2. **Water Pollution Control (BMPs)(LS):** Furnish, install, implement, and maintain water pollution control measures in accordance with accepted Best Management Practices (BMPs) to prevent the discharge of pollutants from the project site. Work includes, but is not limited to, erosion and sediment control, material storage, waste management, and site housekeeping as necessary to comply with applicable regulations and these specifications.
3. **Temporary Access, Traffic Control, and Gate Coordination (LS):** Item includes all labor, materials, equipment, and incidentals necessary to maintain safe and continuous access to the site during construction. Work includes furnishing, installing, maintaining, and removing temporary fencing, temporary gates, and access control measures as required to accommodate District operations and authorized personnel.

Contractor shall remove the existing gate prior to construction, protect it from damage, and store it at a location approved by the District. Contractor shall be responsible for reinstallation of the existing gate and coordination of electrical reconnection.

Contractor shall coordinate with the District to verify that power is disconnected and the electrical wires are removed prior to commencing any work affecting the gate, traffic loops, or associated conduits. Existing conduits run parallel to the fence and shall be protected in place. Any conduits or electrical components damaged during construction shall be repaired or replaced to equal or better condition at the Contractor's expense prior to placement of asphalt concrete.

Contractor shall furnish and install a temporary vehicle access gate at the existing gate location. Temporary gate shall be a minimum 16-foot-wide double swing gate (two 8-foot gates) equipped with wheels or approved equal, and shall be installed in a manner that provides stable and continuous access throughout construction. Contractor shall provide a minimum of 72 hours notice to the District prior to performing work affecting gate operation or electrical systems.

The item includes coordination with the District and gate system manufacturer for removal of existing traffic loop detectors and for reinstallation by others. Contractor shall sequence construction to allow removal of existing traffic loops and gate prior to paving operations. Reinstallation of traffic loop detectors by others shall be completed after the placement of final asphalt concrete. Contractor shall coordinate schedule accordingly.

Work includes all necessary traffic control, signage, and construction phasing required to maintain safe vehicle and pedestrian circulation and to minimize disruption to District operations. Contractor shall maintain access for District staff and the public at all times unless otherwise approved by the District, and shall provide all necessary traffic control devices, signage, and on-site direction to safely route vehicles and pedestrians through or around the construction area in accordance with the Special Considerations.

Removal of existing traffic loop detectors is included under Bid Item No.4. Reinstallation of traffic loop detectors will be performed by others. All costs associated with temporary access, traffic control, signage, public and employee circulation, coordination with District operations, compliance with Special Considerations, gate removal and reinstallation, coordination, conduit protection and repair, and traffic control shall be considered included in this item.

- 4. Full-Depth Pavement Removal & Replacement (3" AB + 3" AC) (SF):** Item includes all labor, material, equipment, and trucking necessary to grind and remove existing asphalt concrete and aggregate base, and stockpile at the designated area onsite. Item includes preparation and compaction of the subgrade to a minimum of 95 percent relative compaction, placement of 3 inches of Class II Aggregate Base to a minimum of 95 percent relative compaction, and placement of 3 inches of new Type A HMA (3/4") in accordance with Caltrans Standard Specifications, Details, and QC/QA requirements.

The item also includes application of tack coat at all tie-in surfaces. Work limits extend from the front parking lot to the north side of Building A, as shown on the plans (front of the main office). This item also includes spot repairs within the asphalt pavement coating area at the rear of the main office.

Work under this item also includes removal and disposal of existing concrete pavement at the ADA parking stall locations in the front parking lot in front of Building A main entrance, and replacement with the specified 3-inch aggregate base and 3-inch asphalt concrete section to match adjacent pavement. This item includes removal and disposal of existing traffic loop detectors within the project limits, including sawcutting, removal of loop wiring

and sealant, and restoration of the pavement section. Reinstallation of traffic loops will be performed by others after the restoration of pavement section.

5. **Remove & Replace Striping & Wheel Stops (LS):** Item includes all labor, material, equipment, and trucking necessary to remove and replace striping and wheel stops within Base Bid area. Striping and markings are to comply with CAMUTCD and ADA standards. Thermoplastic striping will not be required.
6. **Remove & Replace 8" Thick Reinforced Concrete (SF):** Item includes all labor, material, equipment, and trucking to sawcut, remove, and replace 8" of reinforced concrete. Reinforcement is to be #4 grade 60 rebar at 12-inches on center each way. Contractor is to install minimum 24-inch long #4 dowels with epoxy at any adjacent concrete tie in. Concrete is to be a minimum 6 sack cement with 4,000 psi rating at 28 days. The removed concrete with reinforcement is to be off-hauled and disposed of.
7. **Remove & Replace Concrete Valley Gutter (SF):** Item includes all labor, materials, equipment, and trucking necessary to sawcut, remove, and replace existing valley gutter concrete at the locations shown on the plans. Existing concrete, base material, and debris shall be off-hauled and properly disposed of.

Replacement valley gutter shall generally conform to the applicable San Joaquin County Valley Gutter Detail for materials and section requirements; however, plan dimensions and replacement widths shall match existing field conditions unless otherwise shown on the plans or directed by the District. In addition, reinforcement is to be #4 grade 60 rebar at 12-inches on center each way. New valley gutter shall be constructed with 6 inches of Class 3 concrete over 8 inches of compacted Class II Aggregate Base at 95 percent relative compaction. Work includes excavation, subgrade preparation, fine grading, forming, reinforcement, dowels, expansion joints, finishing, curing, and all incidental work necessary to complete the installation.

All tie-ins to adjacent asphalt concrete and concrete improvements shall be neatly sawcut and restored flush. Finished valley gutter shall match existing flow line and grades and provide positive drainage with no ponding.

8. **Asphalt Pavement Coating (SY):** Item includes all labor, materials, equipment, and incidentals necessary to furnish and apply asphalt pavement coating over existing asphalt concrete surfaces in the areas shown on the plans. Work includes surface preparation, sweeping, cleaning, and removal of dirt, dust, vegetation, debris, oil, grease, and other deleterious materials that may interfere with adhesion. Areas with excessive contamination or failed pavement shall be repaired as directed prior to coating application. New asphalt concrete placed under this contract shall cure a minimum of **30 days** prior to application of asphalt pavement coating.

Asphalt pavement coating shall consist of OverKote by RaynGuard Protective Materials, Inc., or approved equal, and shall be mixed, applied, and cured in accordance with the manufacturer's current published recommendations. Coating shall be applied in one or more coats as required to provide a uniform, continuous finish. Application shall only occur under suitable weather and surface temperature conditions.

Work also includes crack treatment. Crack treatment shall include routing, cleaning, and sealing of cracks as necessary to provide a suitable surface for seal coat application. The item includes treatment of both minor and major cracks, and no separate payment will be

made for crack sealing. All costs associated with crack treatment shall be considered incidental to the asphalt pavement coating item. Crack treatment is expected to be typical for parking lot maintenance and shall be included in the unit price.

The Contractor shall protect adjacent concrete, landscaping, striping, fences, structures, and appurtenances from overspray, tracking, staining, or damage. Any damaged or coated surfaces not intended for treatment shall be cleaned or restored at the Contractor's expense.

Asphalt pavement coating shall be applied to areas shown on the plans. Finished coated surfaces shall be allowed to cure prior to reopening to traffic. Striping shall be paid under Bid Item #5.

- 9. Remove & Replace 6" Storm Drain Pipe (LF):** Item includes all labor, materials, equipment, and trucking necessary to remove and dispose of existing 6-inch asbestos cement (AC) storm drain pipe and to furnish and install new 6-inch PVC SDR-35 storm drain pipe, complete in place. Work includes trenching, shoring as required, bedding, pipe installation, backfill, compaction, and surface restoration to match existing conditions.

Removal and disposal of existing AC (transite) pipe shall be performed in accordance with all applicable federal, state, and local regulations. The Contractor shall have proper certification and training for handling, removal, transport, and disposal of asbestos-containing materials.

The Contractor shall pothole and verify existing utilities and storm drain pipe size, type, and alignment at tie-in locations prior to installation. All necessary fittings, couplings, and connections to existing storm drain systems are included in this item.

Work shall conform to the applicable provisions of the Caltrans Standard Specifications and as shown on the plans.

- 10. Remove & Replace 12" Storm Drain Pipe (LF):** Item includes all labor, materials, equipment, and trucking necessary to remove and dispose of existing 12-inch asbestos cement (AC) storm drain pipe and to furnish and install new 12-inch PVC SDR-35 storm drain pipe, complete in place. Work includes trenching, shoring as required, bedding, pipe installation, backfill, compaction, and surface restoration to match existing conditions.

Removal and disposal of existing AC (transite) pipe shall be performed in accordance with all applicable federal, state, and local regulations. The Contractor shall have proper certification and training for handling, removal, transport, and disposal of asbestos-containing materials.

The Contractor shall pothole and verify existing utilities and storm drain pipe size, type, and alignment at tie-in locations prior to installation. All necessary fittings, couplings, and connections to existing storm drain systems are included in this item.

Work shall conform to the applicable provisions of the Caltrans Standard Specifications and as shown on the plans.

- 11. Asphalt Concrete Dike (Type A) (LF):** Item includes all labor, materials, equipment, and trucking necessary to furnish and install 6-inch asphalt concrete dike (Type A) in accordance

with Caltrans Standard Specifications and applicable Standard Plans. Work includes surface preparation, placement, compaction, and finishing to the lines and grades shown on the plans.

The item includes construction of 5-foot transition tapers at both ends of the dike and all necessary tie-ins to existing pavement and improvements. All costs associated with transitions, tapers, and tie-ins shall be considered incidental to this item.

- 12. Joint Trench (3ea – 4" PVC SCH. 40 & 3-ea 2" PVC SCH. 40) (LF):** Item includes all labor, materials, tools, equipment, and incidentals necessary to construct joint trench conduit at the locations shown on the plans.

Work includes excavation, trench preparation, furnishing and installation of three (3) 4-inch PVC Schedule 40 conduits and three (3) 2-inch PVC Schedule 40 conduits, tracer wire, fittings, spacers, bends, warning tape, backfill, compaction, and all appurtenant work necessary for a complete installation. All conduit ends shall be capped and protected until future use. Contractor shall coordinate trench work with other project improvements and sequence installation to avoid delays to paving operations.

Trench backfill within the conduit trench section shall be included in this item. Final aggregate base, asphalt concrete, concrete, and surface restoration within areas of full-depth pavement reconstruction shall be paid under the applicable pavement or concrete bid items.

- 13. B2436 Pull Box with H20 Rated Steel Lid (EA):** Item includes all labor, materials, tools, equipment, and incidentals necessary to furnish and install B2436 pull boxes with H20 steel lids at the locations shown on the plans.

Work includes excavation, subgrade preparation, furnishing and placement of pull box, conduit knockouts/openings, connection to proposed conduits, backfill, compaction, lid installation, grade adjustment to finished surface, and all appurtenant work necessary for a complete installation.

Pull boxes shall be installed plumb, set to final grade, and located to avoid conflict with striping, wheel stops, sidewalks, and other site improvements where practical. Box lids shall be securely fitted and traffic rated as specified. Any concrete, asphalt concrete, or pavement restoration outside the limits of full-depth reconstruction shall be considered incidental to this item unless otherwise shown on the plans.

1.02 SPECIAL CONSIDERATIONS

- A. Work is to be performed during the weekdays. The contractor will be allowed to work from 7:00am to 5:00pm. The contractor is to coordinate and accommodate SSJID's 24/7 operations as appropriately.
- B. Contractor shall maintain safe and continuous vehicular and pedestrian access to the site at all times and shall coordinate all work activities with the District to minimize disruption to facility operations.

Construction activities shall not be permitted on the 2nd and 4th Tuesday of each month due to scheduled Board meetings. These days shall be considered non-working days and shall not be counted toward the contract time.

Paving operations, including placement of asphalt concrete, shall only be performed on Fridays unless otherwise approved by the District. Contractor shall plan and coordinate all work, including grinding and surface preparation, to accommodate this restriction and ensure paving operations can be completed within the allowable timeframe.

The District will direct staff to utilize alternative parking areas, including near Building B, and will designate public and ADA parking behind Building A during construction. The District will provide notification and general direction to staff and the public regarding parking and access outside of the construction zone.

District Operations and Maintenance staff will be temporarily relocated offsite to the District control room during construction. However, periodic access through the gate will be required at the beginning and end of work shifts. Contractor shall coordinate with the District to accommodate this limited access.

A District representative or unarmed security guard will be provided by the District near the access gate to assist with public access and general safety outside of the construction area. This measure is for District operational support only and shall not relieve the Contractor of responsibility for site safety, traffic control, or protection of the public within the construction zone.

Contractor shall be responsible for providing all traffic control, signage, and on-site direction necessary to safely route vehicles and pedestrians through or around the construction area. Contractor shall ensure clear and safe access is maintained through the work zone at all times. Contractor shall sequence and phase the work to maintain access to the facility, including employee and public access, at all times.

- C. A weekly updated schedule is to be provided to the District.
- D. Survey and layout services will be provided by the District, when required.
- E. The Contractor shall obtain and maintain an active and valid USA ticket in excavation areas at all times.
- F. Compaction testing is to be performed by an independent laboratory and shall be provided by the Owner at the Owner's discretion per the District's specifications. Contractor is to provide test pits and coordinate with the District Inspector on testing locations.
- G. Construction water can be made available by the District onsite through the 2-inch water service stand.
- H. The Contractor may utilize the District's property for a laydown yard and staging area.
- I. The contractor is responsible for all implementation and monitoring of storm water pollution prevention and dust control measures. Including any BMP's, track-out devices, concrete wash out, and street sweeper cleaning as necessary.

APPENDIX A
CONTRACT PLAN SET

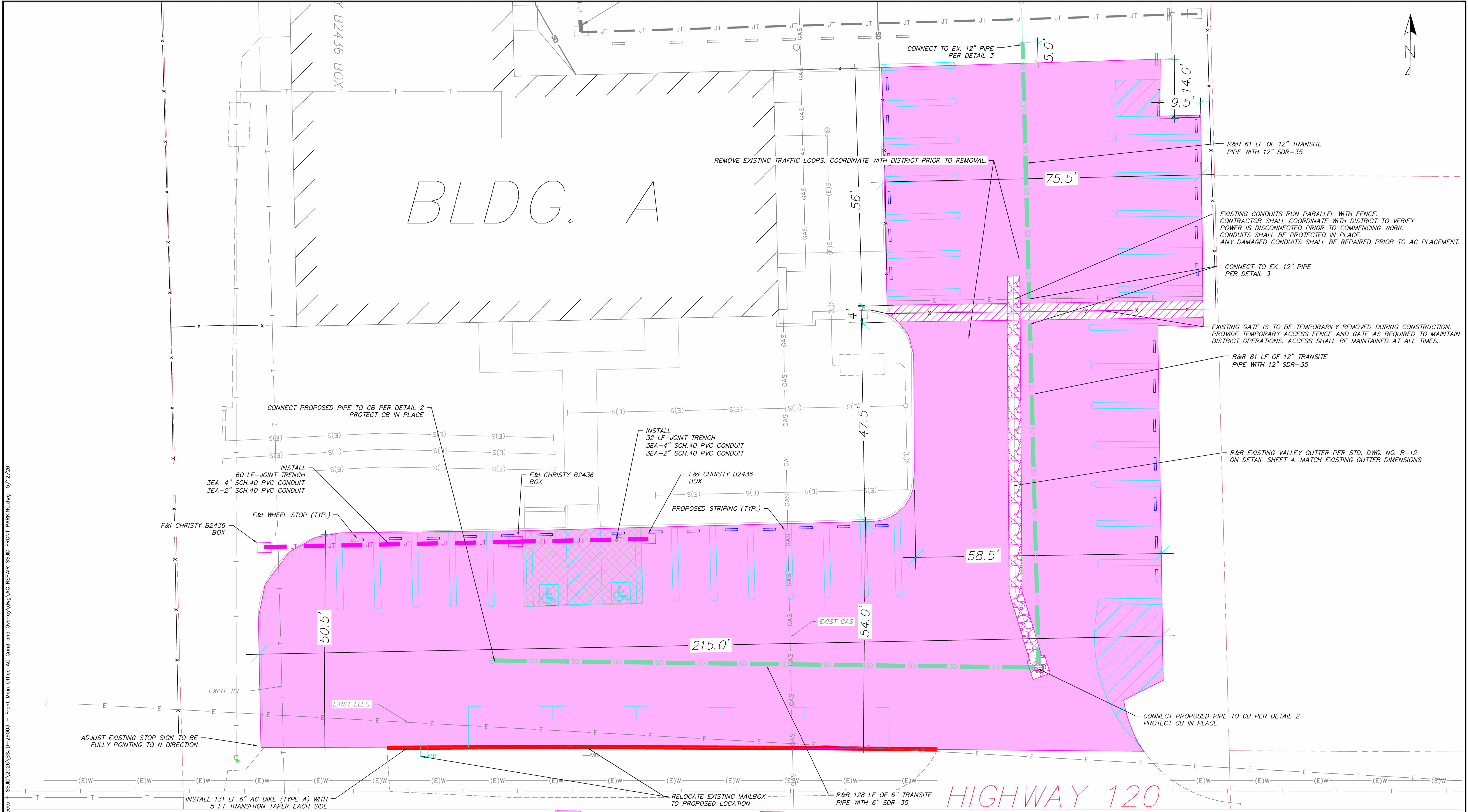

W:\Engineering\Projects + SSJID\2026\SSJID-26003 - Front Main Office AC Grind and Overlay\SSJID FRONT PARKING.dwg 5/12/26

- NOTES:**
- 1) CONTRACTOR TO CONTACT USA NORTH 811 DIG ALERT PRIOR TO ANY EXCAVATION.
 - 2) CONTRACTOR TO COORDINATE WITH SSJID STAFF TO LOCATE AND POTHOLE ALL PRIVATE UTILITIES ONSITE.
 - 3) CONTRACTOR TO COORDINATE & PROVIDE SSJID EMPLOYEE PARKING AND ACCESS TO BUILDINGS A-D AT ALL TIMES.
 - 4) CONTRACTOR SHALL COORDINATE TRAFFIC LOOP WORK, GATE WORK, AND ELECTRICAL WITH DISTRICT AND GATE MANUFACTURER PRIOR TO PAVING OPERATIONS.

- 6" AC/AB GRIND, REPLACE AC & AB
- ASPHALT PAVEMENT COATING
- REMOVE AND REPLACE CONCRETE VALLEY GUTTER
- 8" REINFORCED CONCRETE REMOVE & REPLACE
- #4 REBAR @ 12" OC EACH WAY, #4 DOWEL @ 12" OC INTO EX
- REMOVE EXISTING CONCRETE

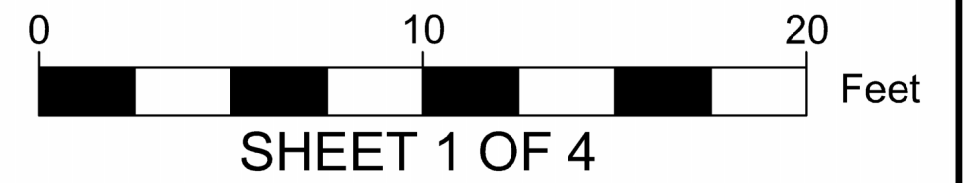

REVISIONS:			
NO.	DESC.	BY	DATE

DATE: 5/12/2026
 SCALE: 1"=10'
 DRAWN: ET
 CHECKED: CJP
 DATUM: NAVD 88

MAIN OFFICE PAVEMENT IMPROVEMENT PROJECT
PHASE 2
 11011 E. HIGHWAY 120
 MANTECA, CALIFORNIA

SOUTH SAN JOAQUIN IRRIGATION DISTRICT

MAILING ADDRESS:
P.O. BOX 747
RIPON, CA 95366-0747

PHYSICAL ADDRESS:
11011 EAST HIGHWAY 120
MANTECA, CA 95366-9750

DISTRICT OFFICE:
PHONE - (209) 249-4600
FAX - (209) 249-4640



W:\Engineering\Projects - SSJID\2026\SSJID-26003 - Front Main Office AC Grind and Overlay\AC REPAIR SSJID FRONT PARKING.dwg 5/12/26

NOTES:

- 1) CONTRACTOR TO CONTACT USA NORTH 811 DIG ALERT PRIOR TO ANY EXCAVATION.
- 2) CONTRACTOR TO COORDINATE WITH SSJID STAFF TO LOCATE AND POTHOLE ALL PRIVATE UTILITIES ONSITE.
- 3) CONTRACTOR TO COORDINATE & PROVIDE SSJID EMPLOYEE PARKING AND ACCESS TO BUILDING A & BUILDING B AT ALL TIMES.

- 6" AC/AB GRIND, REPLACE AC & AB
- ASPHALT PAVEMENT COATING
- REMOVE AND REPLACE CONCRETE VALLEY GUTTER
- 8" REINFORCED CONCRETE REMOVE & REPLACE
#4 REBAR @ 12" OC EACH WAY, #4 DOWEL @ 12" OC INTO EX

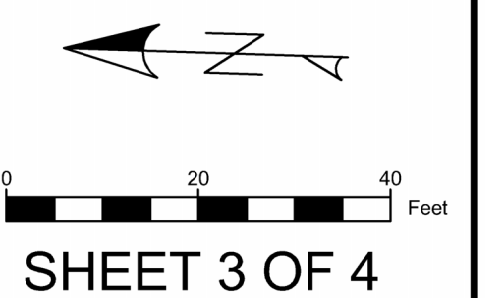

SHEET 3 OF 4

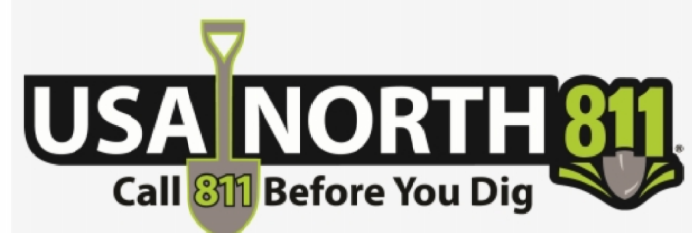

REVISIONS:			
NO.	DESC.	BY	DATE

DATE: 5/12/2026
 SCALE: 1"=20'
 DRAWN: ET
 CHECKED: CJP
 DATUM: NAVD 88

MAIN OFFICE PAVEMENT IMPROVEMENT PROJECT
 PHASE 2
 11011 E. HIGHWAY 120
 MANTECA, CALIFORNIA

SSJID SOUTH SAN JOAQUIN IRRIGATION DISTRICT

MAILING ADDRESS: P.O. BOX 747, RIPON, CA 95366-0747
 PHYSICAL ADDRESS: 11011 EAST HIGHWAY 120, MANTECA, CA 95366-9750
 DISTRICT OFFICE: PHONE - (209) 249-4600, FAX - (209) 249-4640

W:\Engineering\Projects - SSJID\2026\SSJID-26003 - Front Main Office AC Grind and Overlay\SSJID FRONT PARKING.dwg 5/12/26

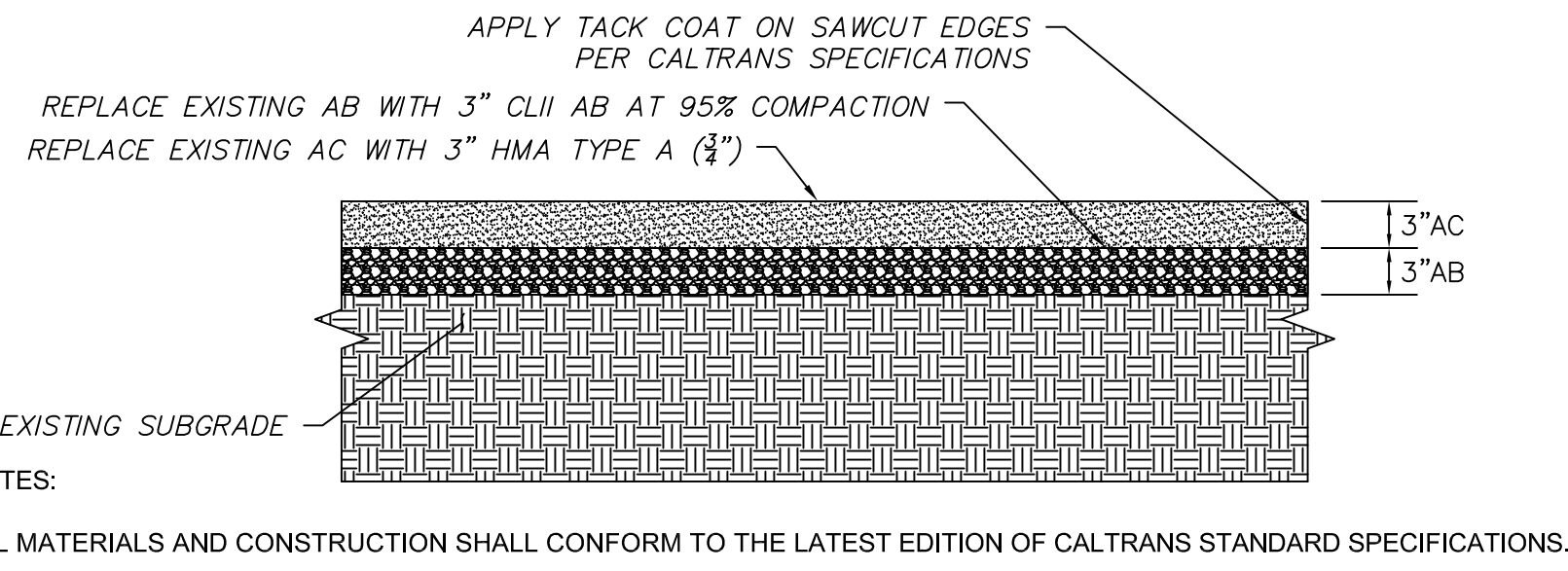

**DETAIL 1:
PAVEMENT SECTION FULL DEPTH
RECONSTRUCTION**
NTS

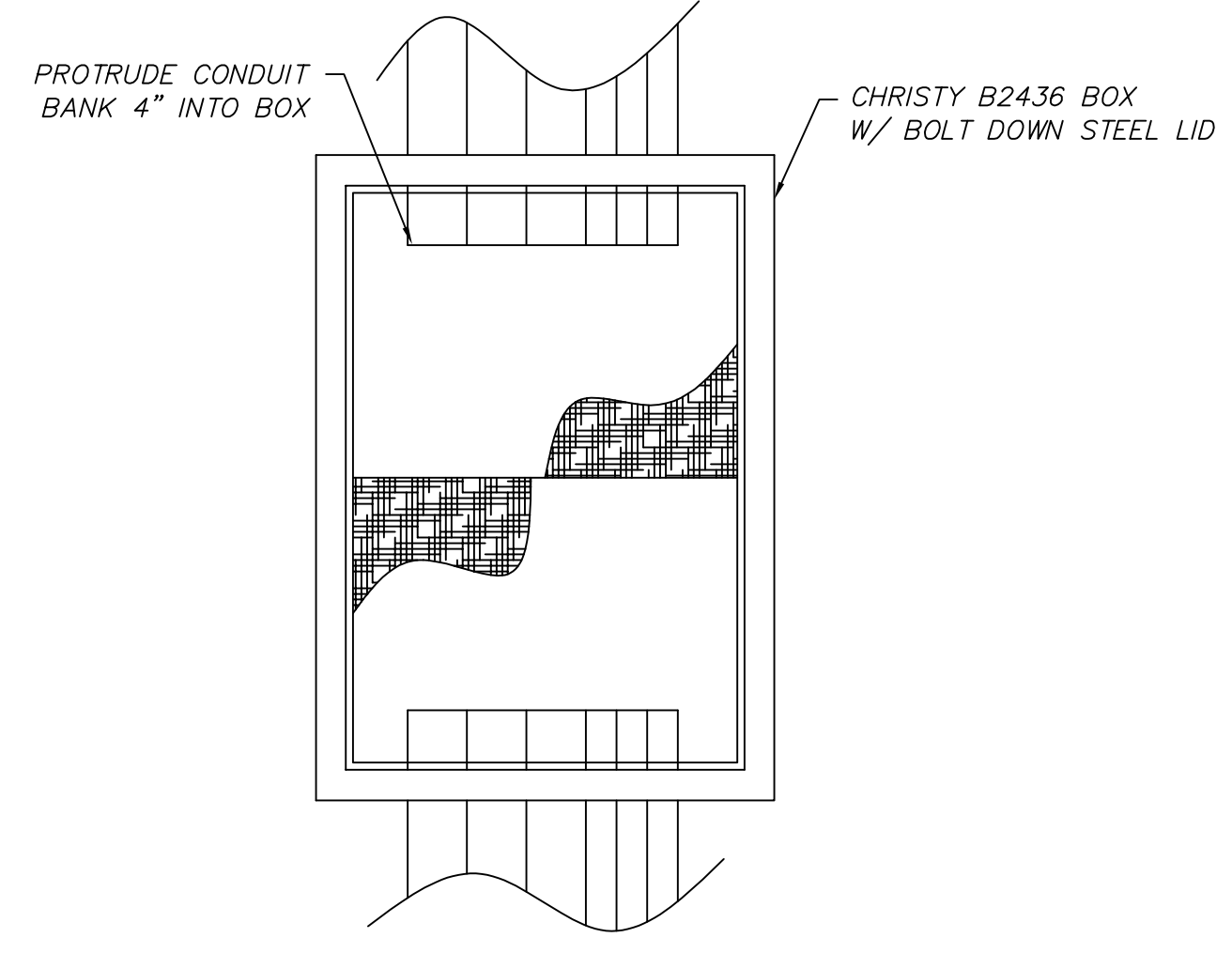

**DETAIL 4:
B2436 PULL BOX WITH H2O STEEL LID**
NTS

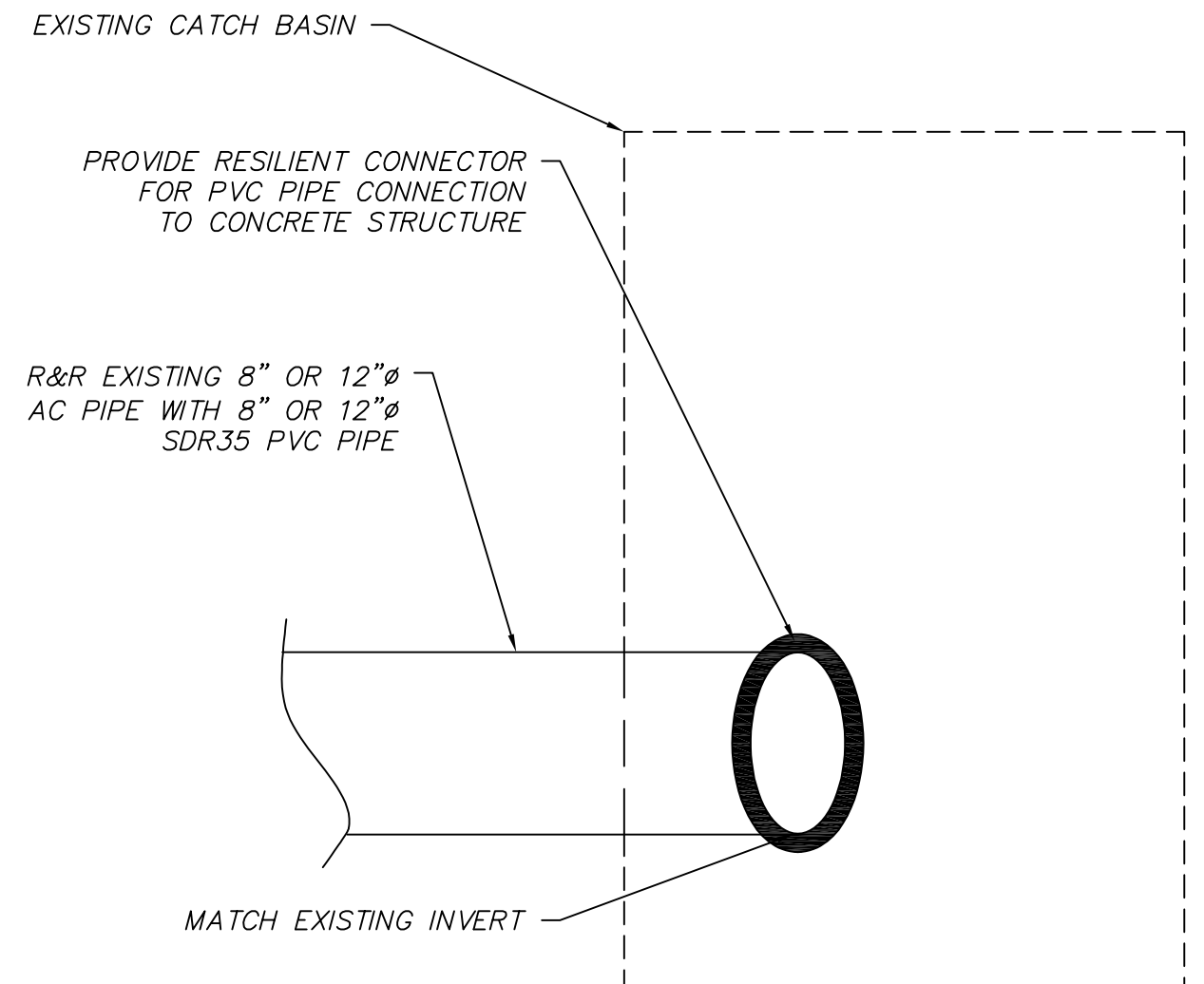

**DETAIL 2:
CONNECTION BETWEEN PVC PIPE
AND CONCRETE STRUCTURE**
NTS

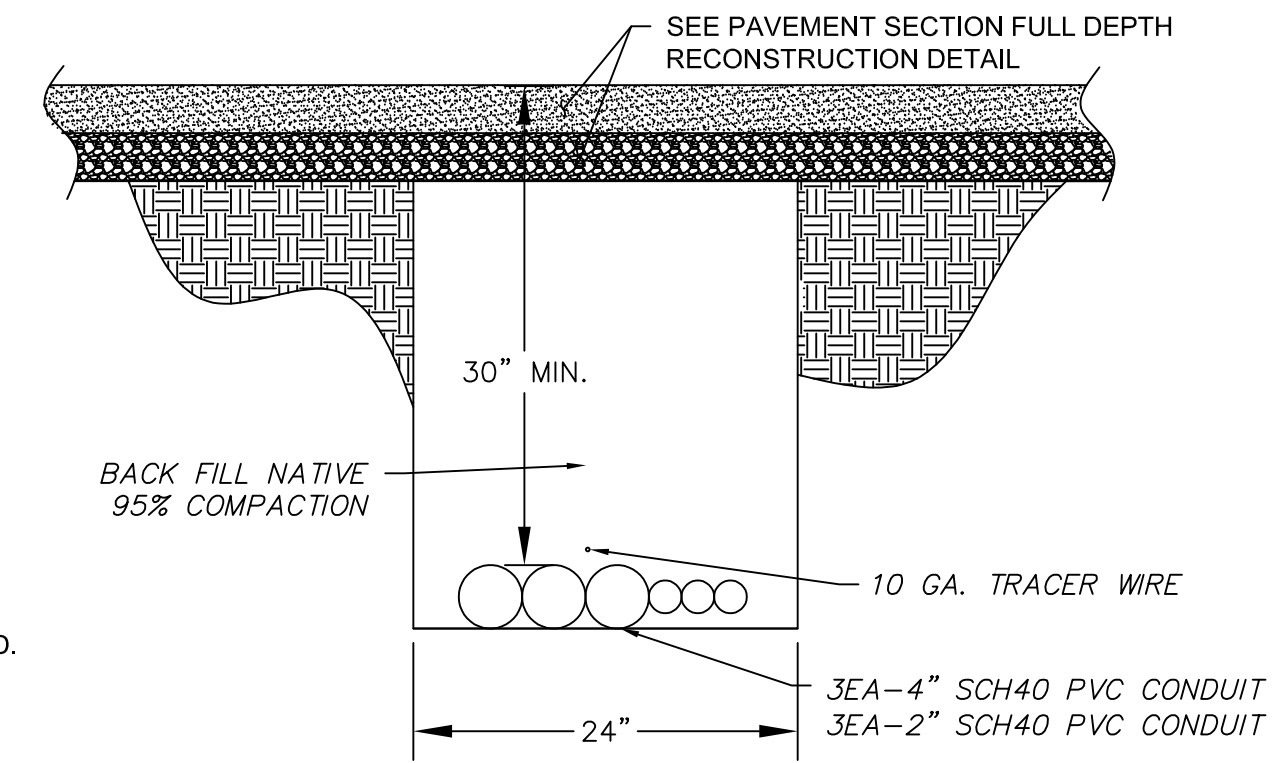
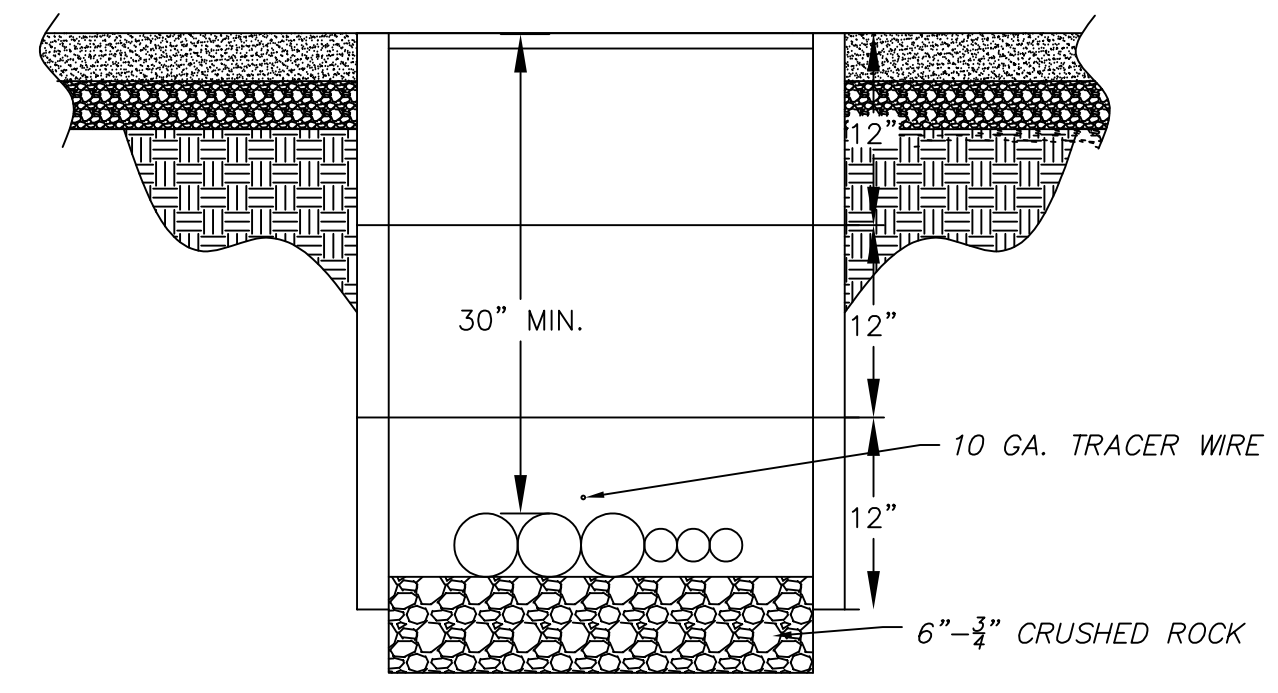

**DETAIL 5:
JOINT TRENCH**
NTS

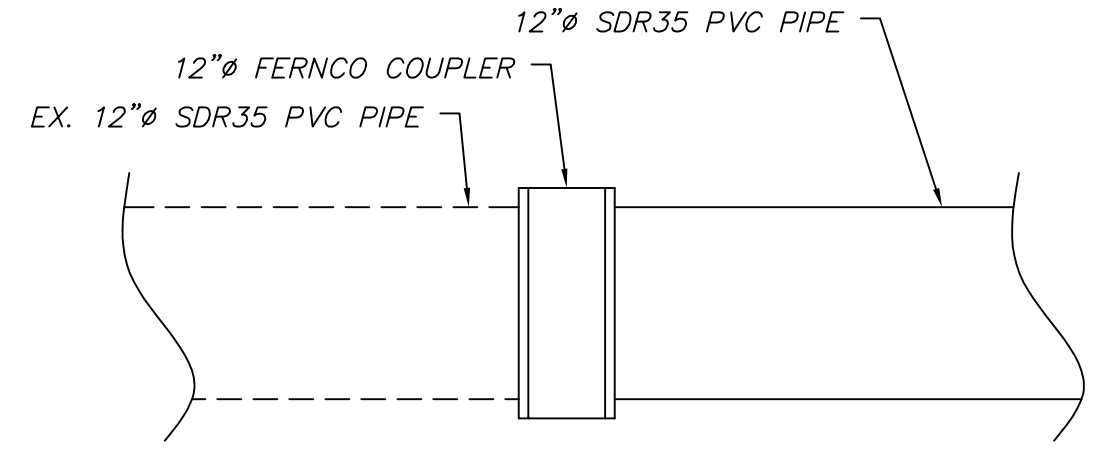

**DETAIL 3:
PROPOSED TO EXISTING PVC PIPE
CONNECTION**
NTS

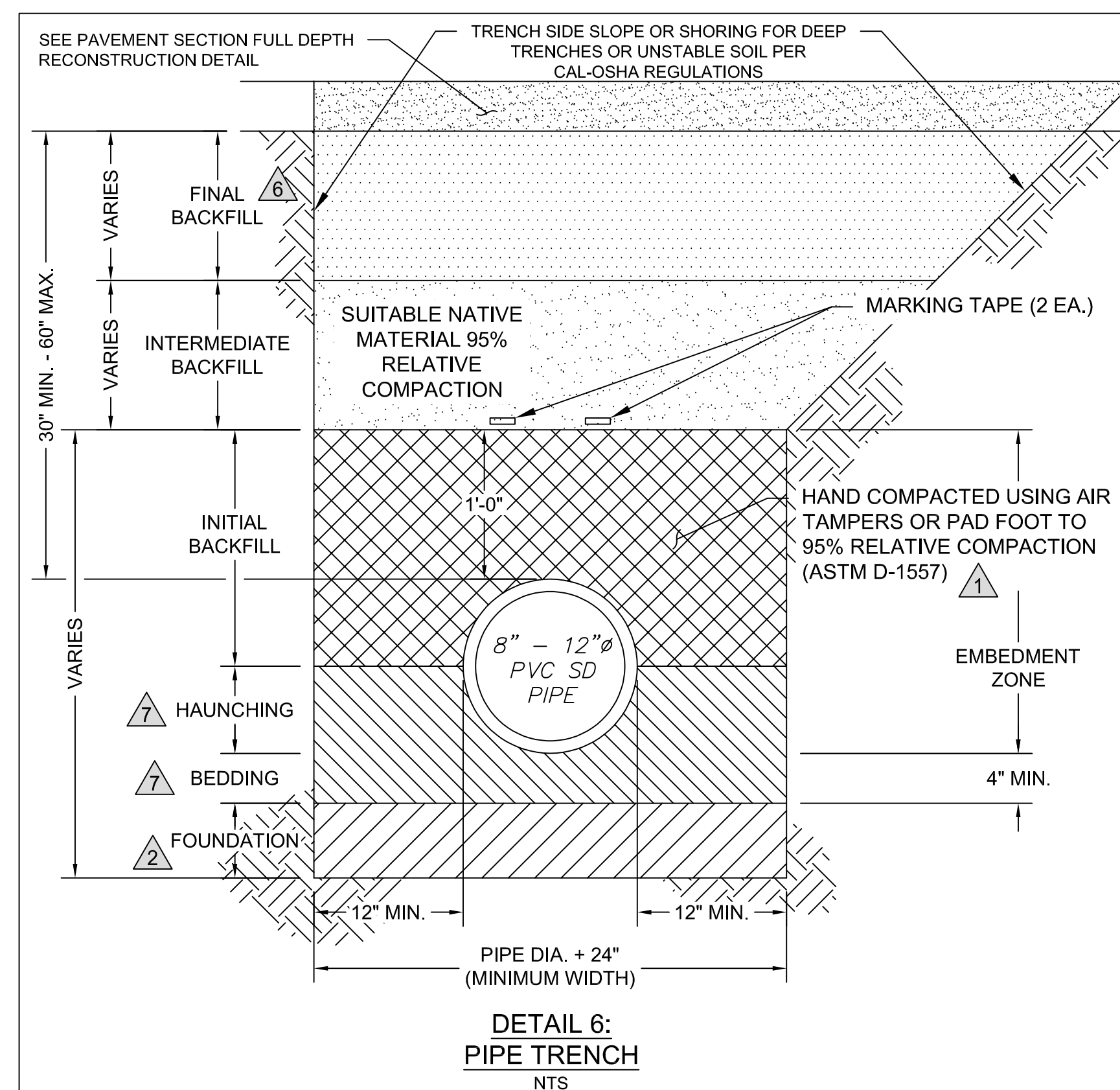

**DETAIL 6:
PIPE TRENCH**
NTS

- CONSTRUCTION NOTES**
1. COMPACTED EARTHFILL SHALL MEET 95% MAXIMUM RELATIVE COMPACTION WITHIN PAVED AREAS AND 90% IN UNPAVED AREAS (ASTM D-1557) AND BE ACCOMPLISHED BY MANUALLY DIRECTED HAND COMPACTORS TO A MINIMUM DEPTH OF 12 INCHES OVER TOP OF PIPE. THE MAXIMUM LAYER THICKNESS SHALL BE 12 INCHES BEFORE COMPACTION. WATER JETTING AS AN ALTERNATIVE TO MANUAL COMPACTION MAY BE ALLOWED IN SANDY LOCATIONS WITHIN THE DISTRICT AS DETERMINED BY SSJID ENGINEER AT PRE-CONSTRUCTION MEETING.
 2. ALL STRUCTURE SUBGRADES TO BE INSPECTED BY THE SSJID ENGINEER PRIOR TO BACKFILL. SUBGRADES SHALL MEET 95% MAXIMUM RELATIVE COMPACTION (ASTM D-1557).
 3. EARTHFILL SHALL BE SELECT NATIVE MATERIAL, CONTAIN NO MATERIALS OVER 3 INCHES IN DIAMETER OR LENGTH, AND BE COMPACTED AGAINST UNDISTURBED EARTH. FILL MATERIAL SHALL CONTAIN NO SOD, BRUSH, ROOTS, OR OTHER ORGANIC OR UNSUITABLE MATERIAL.
 4. PIPELINE SHALL BE INSTALLED ACCORDING TO MANUFACTURER INSTRUCTIONS AND SPECIFICATIONS.
 5. SSJID REQUIRED COMPACTION TESTS SHALL BE AT THE CONTRACTORS EXPENSE. ANY RETESTS SHALL BE PAID BY THE CONTRACTOR. FREQUENCY AND LOCATION OF THE TESTS TO BE DETERMINED BY THE SSJID ENGINEER.
 6. FINAL BACKFILL SHALL BE 95% RELATIVE COMPACTION WITHIN PAVED AREAS AND 90% IN UNPAVED AREAS (ASTM D-1557).
 7. BEDDING SHALL BE MINIMUM 4 INCHES. BEDDING SHALL CONFORM TO THE SPECIFICATIONS BELOW. SOIL TYPE FOR THIS PROJECT IS ASSUMED TO BE SANDY SOIL.
 - (A) ON SANDY SOIL (BEDDING & HAUNCHING): NATIVE MATERIAL, IF SUITABLE, OR SAND AS APPROVED BY THE SSJID ENGINEER.
 8. SSJID MAY REQUIRE THE USE OF IMPORTED BEDDING MATERIAL IF THE NATIVE SOIL IS DEEMED UNACCEPTABLE FOR USE AS BEDDING.

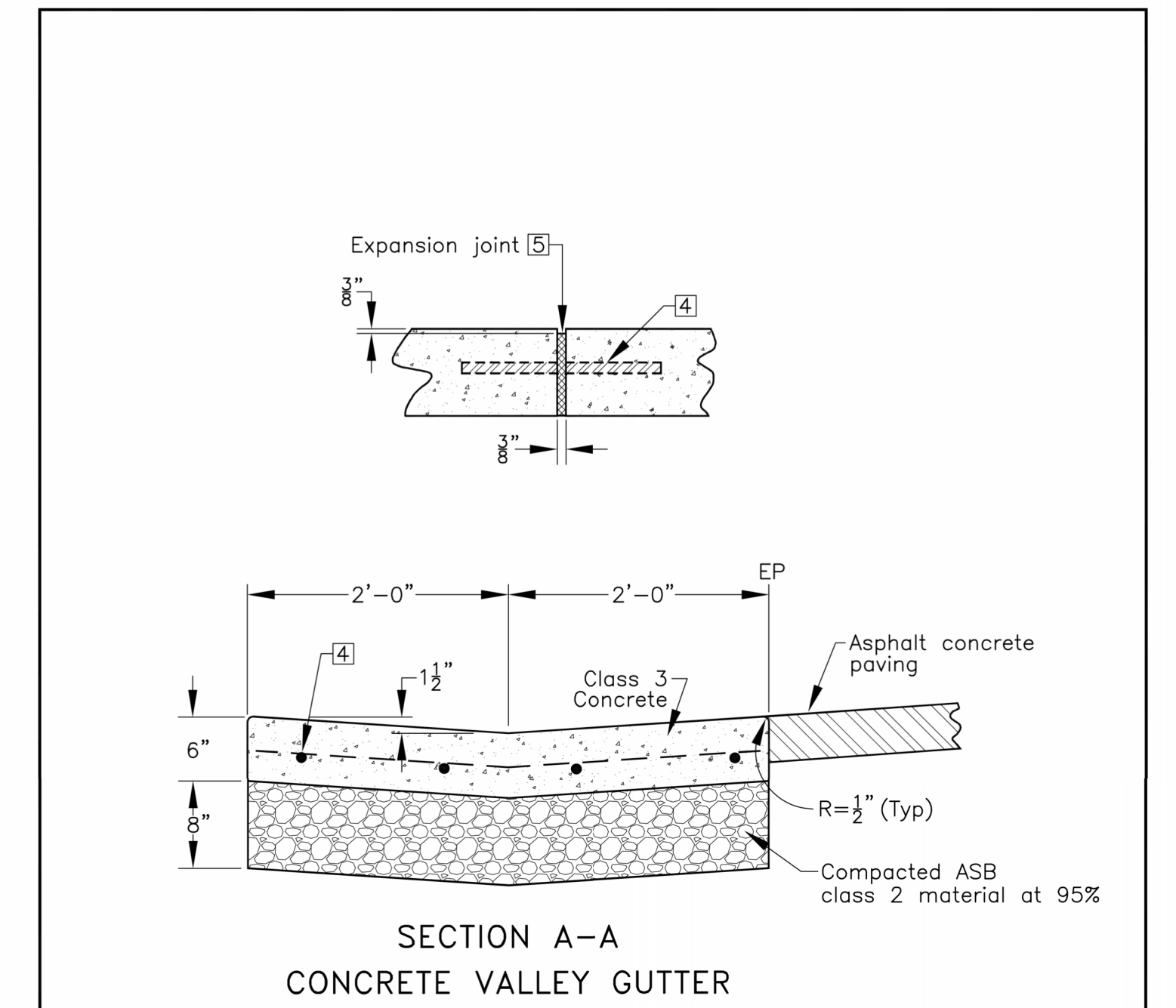

**SECTION A-A
CONCRETE VALLEY GUTTER**

- NOTES:**
1. Construct expansion joints, at 80' max intervals and at the ends of curbs, each side of catchbasins and other fixed objects.
 2. Concrete valley gutter to be used only with specific approval of the agency.
 3. Minimum slope of gutter shall be set at 0.25% unless otherwise approved by the Director of Public Works.
- (4) (4) 3/8" x 24" long steel dowels, greased & wrapped one side through all expansion joints.
 (5) Pre-formed fiber expansion joint filler conforming to ASTM D-1751.

Working for YOU

VALLEY GUTTER DETAIL

COUNTY OF SAN JOAQUIN
DEPARTMENT OF PUBLIC WORKS

Date: DEC 2014

Approved by: *Thomas M. Lee*

No.	Revision Description	Date

Std. Dwg. No. **R-12**

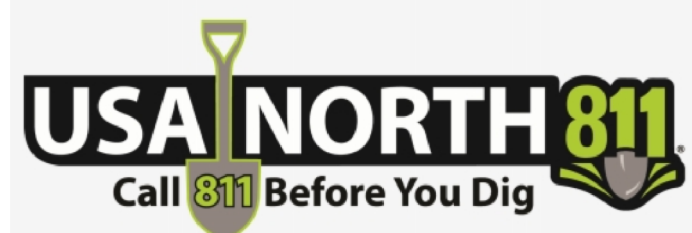

REVISIONS:			
NO.	DESC.	BY	DATE

DATE: 5/12/2026
 SCALE: AS SHOWN
 DRAWN: ET
 CHECKED: CJP
 DATUM: NAVD 88

MAIN OFFICE PAVEMENT IMPROVEMENT PROJECT
 PHASE 2
 11011 E. HIGHWAY 120
 MANTECA, CALIFORNIA

**SOUTH SAN JOAQUIN
IRRIGATION DISTRICT**

MAILING ADDRESS: P.O. BOX 747, RIPON, CA 95366-0747

PHYSICAL ADDRESS: 11011 EAST HIGHWAY 120, MANTECA, CA 95366-9750

DISTRICT OFFICE: PHONE - (209) 249-4600, FAX - (209) 249-4640