

2025 AGRICULTURAL WATER MANAGEMENT PLAN



FINAL

April 2026

Intentionally Left Blank

South San Joaquin Irrigation District

**2025 AGRICULTURAL WATER
MANAGEMENT PLAN**

**Prepared in Accordance with
the Water Conservation Act of 2009 (Senate Bill x7-7) and
the 2018 Water Conservation Legislation (Assembly Bill 1668 and Senate Bill 606)**

April 2026

FINAL

Intentionally Left Blank

PREFACE

This Agricultural Water Management Plan (AWMP or Plan) has been prepared by South San Joaquin Irrigation District (SSJID or District) in accordance with the requirements of the Water Conservation Act of 2009 (SBx7-7) and the 2018 Water Conservation Legislation (AB 1668 and SB 606). SSJID supplies agricultural water to more than 50,000 acres, and is therefore required by California law to adopt and implement an AWMP and submit the AWMP to the California Department of Water Resources (DWR).

SBx7-7 modified Division 6 of the California Water Code (CWC or Code), adding Part 2.55 (commencing with §10608) and replacing Part 2.8 (commencing with §10800). In particular, SBx7-7 requires all agricultural water suppliers to prepare and adopt an update to their AWMP as set forth in the CWC and the California Code of Regulations (CCR) on or before December 31, 2015. The Plan must be updated every 5 years thereafter (§10820 (a)). Additionally, the CWC requires suppliers to implement certain efficient water management practices (EWMPs).

The 2018 Water Conservation Legislation (AB 1668 and SB 606) updated the 2009 Water Management Planning Act to provide more information and analysis regarding the agricultural water supplier's system management and evaluation.

This Plan is the 5-year update to the SSJID 2020 AWMP, last adopted and submitted to DWR in 2021 in accordance with SBx7-7. This update to the AWMP must be adopted by April 1, 2026, and electronically submitted to DWR no later than 30 days after adoption.

The main resources used to develop this 2025 Plan were the SSJID 2020 AWMP, the CWC itself, the Public Review Draft 2025 AWMP Guidebook, and the relevant sections of the CCR.

An AWMP checklist is provided on the following pages, identifying the location(s) in the AWMP within which each of the applicable requirements of the CWC and CCR are addressed. This checklist is intended to support efficient review of the AWMP to verify compliance with the Law.

Intentionally Left Blank

AWMP CHECKLIST

Cross Reference Table of South San Joaquin Irrigation District 2025 Agricultural Water Management Plan to Relevant Sections of the California Water Code

AWMP Section	Guidebook Location	Description	Water Code Section (or as identified)
Preface	1.4	AWMP Required?	10820, 10608.12
Preface; 3.3	1.4	At least 25,000 irrigated acres	10853
N/A	1.4	10,000 to 25,000 acres and funding provided	10853
Preface; 2.1	1.4	April 1, 2026 update	10820 (a)
Preface; 2.1	1.4 A.2	AWMP submitted to DWR no later than 30 days after adoption; AWMP submitted electronically	10820(a)(2)(B)
Preface; 2.1	1.4 B	5-year cycle update	10820 (a)
N/A	1.4 B	New agricultural water supplier after December 31, 2012 - AWMP prepared and adopted within 1 year	10820 (b)
N/A	1.6, 5	USBR water management/conservation plan:	10828(a)
N/A	1.6, 5.1	Adopted and submitted to USBR within the previous four years, AND	10828(a)(1)
N/A	1.6, 5.1	The USBR has accepted the water management/conservation plan as adequate	10828(a)(2)
N/A	1.4 B	UWMP or participation in area wide, regional, watershed, or basin wide water management planning: does the plan meet requirements of SB X7-7 2.8	10829
1.2; 1.3	3.1A	Description of previous water management activities	10826(d)
2.2; Appendix G	3.1 B.1	Was each city or county within which supplier provides water supplies notified that the agricultural water supplier will be preparing or amending a plan?	10821(a)

AWMP Section	Guidebook Location	Description	Water Code Section (or as identified)
2.2; Appendix G	3.2 B.2	Was the proposed plan available for public inspection prior to plan adoption?	10841
2.2; Appendix G	3.1 B.2	Publicly-owned supplier: Prior to the hearing, was the notice of the time and place of hearing published within the jurisdiction of the publicly owned agricultural water supplier in accordance with Government Code 6066?	10841
2.2; Appendix G	3.1 B.2	14 days notification for public hearing	GC 6066
2.2; Appendix G	3.1 B.2	Two publications in newspaper within those 14 days	GC 6066
2.2; Appendix G	3.1 B.2	At least 5 days between publications? (not including publication date)	GC 6066
N/A	3.1 B.2	Privately-owned supplier: was equivalent notice within its service area and reasonably equivalent opportunity that would otherwise be afforded through a public hearing process provided?	10841
2.2; Appendix G	3.1 C.1	After hearing/equivalent notice, was the plan adopted as prepared or as modified during or after the hearing?	10841
2.2; Appendix G	3.1 C.2	Was a copy of the AWMP, amendments, or changes, submitted to the entities below, no later than 30 days after the adoption?	10843(a)
2.2; Appendix G	3.1 C.2	The department.	10843(b)(1)
2.2; Appendix G	3.1 C.2	Any city, county, or city and county within which the agricultural water supplier provides water supplies.	10843(b)(2)
2.2; Appendix G	3.1 C.2	Any groundwater management entity within which jurisdiction the agricultural water supplier extracts or provides water supplies.	10843(b)(3)
2.2; Appendix G	3.1 C.3	Adopted AWMP availability	10844

AWMP Section	Guidebook Location	Description	Water Code Section (or as identified)
2.2; Appendix G	3.1 C.3	Was the AWMP available for public review on the agricultural water supplier's Internet Web site within 30 days of adoption?	10844(a)
N/A	3.1 C.3	If no Internet Web site, was an electronic copy of the AWMP submitted to DWR within 30 days of adoption?	10844(b)
2.4; 7.5	3.1 D.1	Implement the AWMP in accordance with the schedule set forth in its plan, as determined by the governing body of the agricultural water supplier.	10842
3	3.3	Description of the agricultural water supplier and service area including:	10826(a)
3.3	3.3 A.1	Size of the service area.	10826(a)(1)
3.3; 3.4	3.3 A.2	Location of the service area and its water management facilities.	10826(a)(2)
3.5	3.3 A.3	Terrain and soils.	10826(a)(3)
3.6	3.3 A.4	Climate.	10826(a)(4)
3.7	3.3 B.1	Operating rules and regulations.	10826(a)(5)
3.8	3.3 B.2	Water delivery measurements or calculations.	10826(a)(6)
3.9	3.3 B.3	Water rate schedules and billing.	10826(a)(7)
3.10; Appendix D	3.3 B.4	Water shortage allocation policies and detailed drought plan	10826(a)(8) 10826.2
5.5	3.4	Water uses within the service area, including all of the following:	10826(b)(5)
5.5.1	3.4 A	Agricultural.	10826(b)(5)(A)
5.5.2	3.4 B	Environmental.	10826(b)(5)(B)
5.5.3	3.4 C	Recreational.	10826(b)(5)(C)
5.5.4	3.4 D	Municipal and industrial.	10826(b)(5)(D)
5.5.5	3.4 E	Groundwater recharge, including estimated flows from deep percolation from irrigation and seepage	10826(b)(5)(E)
4; 4.1	3.5 A	Description of the quantity of agricultural water supplier's supplies as:	10826(b)

AWMP Section	Guidebook Location	Description	Water Code Section (or as identified)
4.2	3.5 A.1	Surface water supply.	10826(b)(1)
4.3	3.5 A.2	Groundwater supply.	10826(b)(2)
4.4	3.5 A.3	Other water supplies, including recycled water	10826(b)(3)
5.6	3.5 A.4	Drainage from the water supplier's service area.	10826(b)(6)
4.5	3.5 B	Description of the quality of agricultural waters suppliers supplies as:	10826(b)
4.5.1	3.5 B.1	Surface water supply.	10826(b)(1)
4.5.2	3.5 B.2	Groundwater supply.	10826(b)(2)
4.5.1	3.5 B.3	Other water supplies.	10826(b)(3)
4.5.1	3.5 C	Source water quality monitoring practices.	10826(b)(4)
5; 5.7	3.6	Annual water budget based on the quantification of all inflow and outflow components for the service area.	10826(c)
5.9	3.7 C	Identify water management objectives based on water budget to improve water system efficiency	10826(f)
5.10	3.8 D	Quantify the efficiency of agricultural water use	10826(h)
6	3.9	Analysis of climate change effect on future water supplies analysis	10826(d)
5.10; 7	4	Water use efficiency	10826(e)
7		information required pursuant to § 10608.48.	
7; 7.5; Table 7-1; Table 7-5	4.1	Implement efficient water management practices (EWMPs)	10608.48(a)
7.3.1; 7.5; Appendix A	4.1 A	Implement Critical EWMP: Measure the volume of water delivered to customers with sufficient accuracy to comply with subdivision (a) of §531.10 and to implement paragraph (2).	10608.48(b)

AWMP Section	Guidebook Location	Description	Water Code Section (or as identified)
7.3.2; 7.5	4.1 A	Implement Critical EWMP: Adopt a pricing structure for water customers based at least in part on quantity delivered.	10608.48(b)
7.4; 7.5	4.1 B	Implement additional locally cost-effective and technically feasible EWMPs	10608.48(c)
7.4; 7.5; Table 7-1; Table 7-5	4.1 C	If applicable, document (in the report) the determination that EWMPs are not locally cost- effective or technically feasible	10608.48(d)
7.4; 7.5; Table 7-1; Table 7-5	4.1 C	Include a report on which EWMPs have been implemented and planned to be implemented	10608.48(d)
7-6; Table 7-9	4.1 C	Include (in the report) an estimate of the water use efficiency improvements that have occurred since the last report, and an estimate of the water use efficiency improvements estimated to occur five and 10 years in the future.	10608.48(d)
N/A	5	USBR water management/conservation plan may meet requirements for EWMPs	10608.48(f)
N/A	6 A	Lack of legal access certification (if water measuring not at farm gate or delivery point)	CCR§597.3(b)(2)(A)
N/A	6 B	Lack of technical feasibility (if water measuring not at farm gate or delivery point)	CCR§597.3(b)(1)(B), §597.3(b)(2)(B)
N/A	6 A, 6 B	Delivery apportioning methodology (if water measuring not at farm gate or delivery point)	CCR§597.3.b(2)(C),
Appendix A	6 C	Description of water measurement BPP	CCR §597.4(e)(2)
Appendix A	6 D	Conversion to measurement to volume	CCR §597.4(e)(3)
Appendix A	6 E	Existing water measurement device corrective action plan? (if applicable, including schedule, budget and finance plan)	CCR §597.4(e)(4)

Intentionally Left Blank

TABLE OF CONTENTS

Preface.....	i
AWMP Checklist.....	iii
Table of Contents.....	ix
List of Tables.....	xiii
List of Figures.....	xiv
Acronyms and Abbreviations.....	xvi
Executive Summary.....	1
Introduction.....	1
Water Management Objectives and Actions.....	2
Implementation of Efficient Water Management Practices.....	3
Conclusion.....	3
1 Introduction.....	11
1.1 SSJID History.....	12
1.2 Previous Water Management Activities in SSJID.....	13
1.3 Other Water Management Activities.....	15
2 Plan Preparation.....	18
2.1 AWMP Preparation.....	18
2.2 Public Participation.....	18
2.3 Regional Coordination.....	19
2.4 Plan Implementation.....	19
3 Background and Description of Service Area.....	21
3.1 Formation.....	21
3.2 District Organization.....	22
3.3 Size and Location of Service Area.....	25
3.4 SSJID Distribution System.....	30
3.4.1 Water Supply and Storage.....	30
3.4.2 Canals and Laterals.....	31
3.4.3 System Modernization Projects.....	31
3.4.4 Delivery Structures.....	35
3.4.5 Drainage and Spillage.....	35
3.4.6 Groundwater Production.....	36
3.4.7 Water Treatment Plant.....	37
3.4.8 Operational Divisions and Water Deliveries.....	40
3.4.9 Delivery Flexibility.....	42

3.5	Terrain and Soils	43
3.6	Climate	44
3.7	Operating Rules and Regulations	45
3.8	Water Delivery Measurement and Calculation	45
3.8.1	Boundary and System Flow Measurement	45
3.8.2	Water Delivery Measurement and Calculation	47
3.9	Water Rate Schedules and Billing	51
3.10	Water Shortage Allocation Policies and Contingency Plan	52
3.11	Policies Addressing Wasteful Use of Water	54
4	Inventory of Water Supplies	55
4.1	Overview of Water Supplies	56
4.2	Surface Water Supply	56
4.2.1	Overview	56
4.2.2	Pre-1914 Water Rights and Goodwin Dam	60
4.2.3	Woodward Reservoir and Melones Reservoir	60
4.2.4	Tri-Dam Project	61
4.2.5	New Melones Reservoir	61
4.3	Groundwater Supply	63
4.3.1	Groundwater Supply Wells	64
4.3.2	Subbasin Characteristics	65
4.3.3	Sustainable Groundwater Management	66
4.3.4	Subbasin Groundwater Use and Recharge	67
4.4	Other Water Supplies	67
4.5	Water Quality Monitoring	68
4.5.1	Surface Water, Other Water, and Source Water Quality Monitoring Practices	68
4.5.2	Groundwater Supply Monitoring	69
5	Water Balance	70
5.1	Introduction	70
5.2	Water Balance Overview	70
5.2.1	General Water Balance Methodology	71
5.2.2	Irrigated Lands Root Zone Water Budget Model and Improved Crop Coefficients	74
5.3	Water Budget Calculation and Uncertainty	74
5.3.1	Main Supply Canal Above Woodward Reservoir	75
5.3.2	Woodward Reservoir	75
5.3.3	Main Supply Canal Below Woodward Reservoir and Main Distributary Canal	76
5.3.4	District Laterals	76

5.3.5	Irrigated Lands	76
5.3.6	Drainage System	77
5.3.7	Flow Path Uncertainty	78
5.4	Hydrologic Year Types in SSJID.....	82
5.5	Water Uses	83
5.5.1	Agricultural	84
5.5.2	Environmental.....	87
5.5.3	Recreational	89
5.5.4	Municipal and Industrial	89
5.5.5	Groundwater Recharge	93
5.5.6	Transfers and Exchanges	96
5.5.7	Other Water Uses.....	98
5.6	Drainage	98
5.6.1	SSJID Boundary Outflows.....	98
5.7	Water Accounting (Summary of Water Balance Results)	102
5.7.1	Main Supply Canal Above Woodward Reservoir	103
5.7.2	Woodward Reservoir	103
5.7.3	Main Supply Canal below Woodward Reservoir and Main Distributary Canal ..	104
5.7.4	District Laterals.....	105
5.7.5	Irrigated Lands	105
5.7.6	Drainage System	106
5.8	Water Supply Reliability	120
5.8.1	Bay-Delta Water Quality Control Plan	120
5.8.2	SGMA and Groundwater Sustainability Plan	121
5.9	Water Management Objectives	122
5.10	Water Use Efficiency.....	125
5.10.1	Water Use Efficiency Components.....	125
5.10.2	Water Use Efficiency Fraction.....	127
6	Climate Change	129
6.1	Introduction	129
6.2	Potential Climate Change Effects	129
6.2.1	Sources of Information Describing Potential Climate Change Effects	130
6.2.2	Summary of Potential Climate Change Effects	131
6.3	Potential Impacts on Water Supply and Quality	143
6.4	Potential Impacts on Water Demand.....	144
6.5	Potential Strategies to Mitigate Climate Change Impacts.....	145
6.6	Additional Resources for Water Resources Planning for Climate Change.....	148

6.6.1	Local and Regional Resources	148
6.6.2	State Resources	149
7	Efficient Water Management Practices	152
7.1	Overview	152
7.2	Water Master Plan	153
7.3	Mandatory EWMPs	154
7.3.1	Delivery Measurement Accuracy (10608.48.b(1))	154
7.3.2	Volumetric Pricing (10608.48.b(2))	155
7.4	Additional EWMPs	156
7.4.1	Alternative Land Use (10608.48.c(1))	156
7.4.2	Recycled Water Use (10608.48.c(2)).....	157
7.4.3	Capital Improvements for On-Farm Irrigation Systems (10608.48.c(3)).....	157
7.4.4	Incentive Pricing Structures (10608.48.c(4)).....	158
7.4.5	Lining or Piping of Distribution System and Construction of Regulating Reservoirs (10608.48.c(5)).....	161
7.4.6	Increased Water Ordering and Delivery Flexibility (10608.48.c(6))	162
7.4.7	Supplier Spill and Tailwater Recovery Systems (10608.48.c(7)).....	164
7.4.8	Increase Planned Conjunctive Use (10608.48.c(8))	165
7.4.9	Automate Canal Control Structures (10608.48.c(9)).....	167
7.4.10	Facilitate Pump Testing (10608.48.c(10))	168
7.4.11	Designate Water Conservation Coordinator (10608.48.c(11)).....	168
7.4.12	Provide for Availability of Water Management Services (10608.48.c(12)).....	168
7.4.13	Evaluate Supplier Policies to Allow More Flexible Deliveries and Storage (10608.48.c(13)).....	169
7.4.14	Evaluate and Improve Efficiencies of Supplier’s Pumps (10608.48.c(14))	171
7.5	Summary of EWMP Implementation Status.....	171
7.6	Evaluation of Water Use Efficiency Improvements	178
8	References	186

LIST OF APPENDICES

Appendix A.	Agricultural Water Measurement Regulation Documentation – Completed and Remaining Corrective Actions.....	190
Appendix B.	Rules and Regulations Governing the Distribution of Water in SSJID	210
Appendix C.	Program Description for 2014 On-Farm Water conservation Program	218
Appendix D.	South San Joaquin Irrigation District Drought Management Plan.....	244
Appendix E.	Eastern San Joaquin Groundwater Subbasin Groundwater Sustainability Plan....	290
Appendix F.	DWR Water Budget Reporting Tables	293
Appendix G.	Public Outreach and Resolution Adopting Plan.....	301

LIST OF TABLES

Table ES-1. Summary of EWMP Implementation Status 5

Table 3-1. Mean Weather Parameters at Manteca CIMIS Station..... 44
 (1994-2024)..... 44

Table 4-1. Summary of Water Supply Volumes in SSJID. 57

Table 4-2. Summary of Water Supplies in SSJID as a Percentage of Total Supply.¹ 58

Table 4-3. Surface Water Supply Summary. 59

Table 4-4. Groundwater Supply Summary. 64

Table 4-5. Other Water Supply Summary. 68

Table 5-1. Water Balance Flow Paths, Supporting Data, and Estimated Uncertainty..... 80

Table 5-2. SSJID Allotment, Precipitation, ET_o, and Hydrologic Year Type (2005-2024). 83

Table 5-3. SSJID Crop Acreages (2005-2024). 86

Table 5-4. Average Acreages and Annual Evapotranspiration Rates for SSJID Crops (2005-2024). 87

Table 5-5. Annual SSJID Supplemental Water under VAMP (2000-2010)..... 88

Table 5-6. SCWSP Phase I and II Allotments by City (acre-feet)..... 90

Table 5-7. Annual Deliveries to Nick C. DeGroot WTP for Urban Water Supply (2005-2024). 91

Table 5-8. SSJID Total Groundwater Recharge (2005-2024) 94

Table 5-9. SSJID Net Groundwater Recharge (2005-2024)..... 95

Table 5-10. SSJID Water Transfers (1997-2024)..... 97

Table 5-11. Estimated SSJID Boundary Outflows (2005-2024). 99

Table 5-12. General Effects of Hydrologic Year Type on SSJID Drainage System Inflows.... 101

Table 5-13. Annual Water Balance for Main Supply Canal Above Woodward Reservoir. 108

Table 5-14. Annual Water Balance for Woodward Reservoir..... 110

Table 5-15. Annual Water Balance for Main Supply Canal Below Woodward Reservoir and Main Distributary Canal. 112

Table 5-16. Annual Water Balance for District Laterals. 114

Table 5-17. Annual Water Balance for Irrigated Lands 116

Table 5-18. Annual Water Balance for Drainage System..... 118

Table 5-19. Water Use Efficiency Components. 126

Table 5-20. Water Use Efficiency Fraction (Total Water Supply Basis). 128

Table 6-1. SSJID Position on Strategies to Mitigate Climate Change Impacts..... 146

Table 7-1. Summary of Critical and Conditional EWMPs (Water Code § 10608.48.b and c.). 152

Table 7-2. 2011 On-Farm Water Conservation Program Conservation Measures and Budget. 158

Table 7-3. General Statistics for 2011 through 2014 On-Farm Water Conservation Program . 159

Table 7-4. Cost Share Amounts by Conservation Measure for 2011 through 2014..... 159

Table 7-5. Summary of EWMP Implementation Status 172

Table 7-6. Summary of WUE Improvements by EWMP 180

Table 7-7. WUE Improvement Categories 183

Table 7-8. Applicability of EWMPs to WUE Improvement Categories. 184

Table 7-9. Evaluation of Relative Magnitude of Past and Future WUE Improvements by EWMP..... 185

Table A-1. Applicability of Selected Measurement Devices at Different Types of Turnouts 199

Table A-2. South San Joaquin Irrigation District Farm Delivery Measurement Options by Delivery Type. 199

Table A-3. Summary of Delivery Measurement Devices Currently Installed in SSJID (2020). 203

Table F-1. Water Budget Inflows (DWR Table V-1). 297

Table F-2. Water Budget Outflows (DWR Table V-2). 298

Table F-3. Water Budget Inflows - Detail. 299

Table F-4. Water Budget Outflows – Detail 300

Table G-1. SSJID Agricultural Water Management Plan – Outreach/Distribution List 305

LIST OF FIGURES

Figure 1-1. New Melones Dam..... 12

Figure 3-3. SSJID Location Map..... 28

Figure 3-4. SSJID Upper Main Supply Canal 30

Figure 3-5. Woodward Reservoir 30

Figure 3-6. Flume Gates at Lateral Heading..... 32

Figure 3-7. SCADA Control Center 33

Figure 3-8. Irrigation Enhancement Project Sam Bologna Reservoir 33

Figure 3-9. SSJID Downstream Level Sensor Locations. 34

Figure 3-10. Surface Irrigation Valves 35

Figure 3-11. French Camp Outlet Canal..... 36

Figure 3-12. Nick C. DeGroot Water Treatment Plant and Robert O. Schulz Solar Farm..... 37

Figure 3-13. SSJID Service Area Divisions 38

Figure 3-14. SSJID Division Manager Measuring Flow 40

Figure 3-15. Woodward Release Gaging Station 46

Figure 3-16. Magnetic Flow Meter..... 48

Figure 3-17. Orchard Valve Installed on SSJID Pipeline 48

Figure 3-18. TruePoint Water Order Entry Screen..... 50

Figure 3-19. On-Farm Meter Portal, Sample Calendar View of Deliveries 51

Figure 4-1. Goodwin Dam 60

Figure 4-2. New Melones Inflow (1895 through 2014 Water Years)..... 62

Figure 4-3. Exceedance Probability of SSJID Stanislaus River Water Supply 63

Figure 4-4. SSJID Groundwater Well..... 65

Figure 5-1. SSJID Water Balance Structure 72

Figure 5-2. Young Almond Orchard in SSJID 84

Figure 5-3. SSJID Cropping (2005-2019). 86

Figure 5-4. Donnells Reservoir..... 89

Figure 5-5. SCWSP Phase I Water System 92

Figure 5-6. Groundwater System Inflows, Outflows, and Net Recharge (2005-2024) 93

Figure 5-7. Chinook Salmon Smolt 96

Figure 5-8. SSJID Boundary Outflow and Lateral Spill Locations..... 102

Figure 6-1. Unimpaired Runoff for Stanislaus River at Goodwin Dam, April – July Runoff... 132
as a Percent of Total Water Year Runoff..... 132

Figure 6-3. Average Total Water Year Projected Stanislaus River Runoff at Los Melones
Reservoir, by Decade and by Climate Change Simulation (Source: Pierce et al., 2018). 134

Figure 6-4. Annual Stanislaus River Runoff at New Melones Reservoir Based on 112
Hydrologic Projections (Gangopadhyay and Pruitt, 2011)..... 135

Figure 6-5. Historical Annual Precipitation and Cumulative Departure from the Mean Annual
Precipitation at Manteca CIMIS Station. 136

Figure 6-14. WWCRA Projected Net Irrigation Water Requirement Change Assuming Non-
Static Phenology. 145

Figure 7-1. SSJID Website 169

Figure 7-2. SSJID Irrigation Newsletter (Winter 2025, Page 1)..... 170

Figure D-3. Monthly Cumulative Woodward Reservoir Releases, 2011- 2016..... 261

Figure D-4. Monthly Cumulative District Pumping, 2011-2016..... 261

Figure D-5. Monthly Cumulative Private Pumping, 2011-2016. 262

Figure D-7. Monthly Cumulative Total Supply, 2011-2016. 263

Figure D-8. Monthly Cumulative SSJID Farm Deliveries, 2011-2016. 264

Figure D-9. Daily Cumulative ET_o , 2011-2016. 265

Figure D-10. Monthly Cumulative Crop ET_{aw} , 2011-2016. 265

ACRONYMS AND ABBREVIATIONS

ADM	acoustic Doppler meter	CIMIS	California Irrigation Management Information System
af	Acre-Feet	CIP	Cast In Place
af/ac	Acre-Feet per Acre	CNRA	California Natural Resources Agency
af/ac-yr	Acre-Feet per Acre per Year	CMIP3	Coupled Model Intercomparison Project Phase 3
APN	Assessor’s Parcel Number	CSJWCD	Central San Joaquin Water Conservation District
ASABE	American Society of Agricultural and Biological Engineers	CVP	Central Valley Project
ASCE	American Society of Civil Engineers	CWC	California Water Code
AW	Applied water	DE	Dauids Engineering, Inc.
AWMP	Agricultural Water Management Plan	DF	Delivery Fraction
AWMC	Agricultural Water Management Council	DM	Division Manager
BCSD	bias comparison and spatial disaggregation	DS	Drainage System
BMO	Basin Management Objective	DWR	California Department of Water Resources
BO	Biological Opinion	ESJGWA	Eastern San Joaquin Groundwater Authority
C2VSim	California Central Valley Groundwater – Surface Water Simulation Model	ESJ IRWMP	Eastern San Joaquin Integrated Regional Water Management Plan
CALFED	CALFED Bay Delta Program	EC	Electrical Conductivity
CCR	California Code of Regulations	EQIP	Environmental Quality Incentives Program
CCUF	Crop Consumptive Use Fraction	ET	Evapotranspiration
CDEC	California Data Exchange Center	ET_{aw}	Crop Evapotranspiration of Applied Water
CDM	Camp, Dresser, & McKee	ET_c	Crop Evapotranspiration
cfs	Cubic Feet per Second	ET_o	Reference Evapotranspiration

ET_{pr}	Crop Evapotranspiration of Precipitation	mi/hr	Miles per Hour
EWMP	Efficient Water Management Practice	MID	Modesto Irrigation District
FCC	Federal Communications Commission	MSC	Main Supply Canal
FCOC	French Camp Outlet Canal	NIWR	net irrigation water requirements
FWUA	Friant Water Users Authority	NPDES	National Pollutant Discharge Elimination System
GCMs	Global climate models	NRCS	Natural Resources Conservation Service
gpm	Gallons per Minute	OID	Oakdale Irrigation District
GDD	Growing degree day	PAT	Program Administration Tool
GSA	Groundwater sustainability agency	PG&E	Pacific Gas and Electric
GSP	Groundwater sustainability plan	PU607	Planning Unit 607
IDC	Integrated Water Flow Model – Demand Calculator	Precip	Precipitation
IL	Irrigated lands	Program	On-Farm Water Conservation Program or Pilot Delivery Measurement Assessment Program
ILRP	Irrigated Lands Regulatory Program	P&P	Provost and Pritchard Consulting Group
in	Inches	psi	Pounds per Square Inch
IWFM	Integrated Water Flow Model	PVC	Polyvinyl Chloride
k_c	Crop Coefficient	RWQCB	Regional Water Quality Control Board
LAFCo	Local Agency Formation Commission	SBx7-7	Senate Bill x7-7, Water Conservation Act of 2009
LMSC	Lower Main Supply Canal	SCADA	Supervisory Control and Data Acquisition
MDC	Main Distributary Canal	SCWSP	South County Water Supply Program
Merced ID	Merced Irrigation District	SDWA	South Delta Water Agency
METRIC	Mapping EvapoTranspiration at high Resolution with Internalized Calibration	SEWD	Stockton East Water District
MGD	million gallons per day		

SGMA	Sustainable Groundwater Management Act	WMF	Water Management Fraction
SIDE	System Improvements for Distribution Efficiency	WCRP	World Climate Research Program
SJCFCWD	San Joaquin County Flood Control and Water Conservation District	WTP	Water Treatment Plant
SLDMWA	San Luis-Delta Mendota Water Agency	WUE	Water Use Efficiency
SOI	Sphere of Influence	WWCRA	West-Wide Climate Risk Assessment
SSJGSA	South San Joaquin Groundwater Sustainability Agency	WWTP	Wastewater Treatment Plant
SSJID	South San Joaquin Irrigation District		
SSURGO	Soil Survey Geographic database		
SWSF	Surface Water Supply Fraction		
TAF	Thousands of Acre-Feet		
TDS	Total Dissolved Solids		
TID	Turlock Irrigation District		
TP	TruePoint		
UMSC	Upper Main Supply Canal		
UCB	University of California at Berkeley		
USBR	United States Bureau of Reclamation		
USGS	United States Geological Survey		
VAMP	Vernalis Adaptive Management Program		
VFD	Variable Frequency Drive		

Intentionally Left Blank

EXECUTIVE SUMMARY

INTRODUCTION

This Agricultural Water Management Plan (AWMP or Plan) has been prepared by the South San Joaquin Irrigation District (SSJID or District) to describe the District’s agricultural water management activities in accordance with the Water Conservation Act of 2009 (SBx7-7) and the 2018 Water Conservation Legislation (AB 1668 and SB 606). Preparation of the AWMP includes a detailed evaluation of the District’s water management operations as they relate to the implementation of mandatory and other locally cost-effective efficient water management practices (EWMPs).

Water for irrigation is foundational to supporting agriculture, the economic engine of San Joaquin County. In 2024, over \$3.14 billion in agricultural commodities were produced in San Joaquin County¹. Key strategies employed by SSJID to support overall water management objectives are the conjunctive management of surface and groundwater supplies and water conservation.

Development of the AWMP represents a substantial effort by SSJID to evaluate its water management, including the development of detailed water balances spanning the period from 2005 to 2024 for the six primary water accounting centers in the District:

1. Main Supply Canal (MSC) Above Woodward Reservoir
2. Woodward Reservoir
3. MSC Below Woodward Reservoir and Main Distributary Canal (MDC)
4. District Laterals
5. Irrigated Lands
6. Drainage System

The AWMP consists of an introduction to SSJID, its history, and previous water management activities; a review of the public participation process to prepare and adopt this AWMP; a detailed description of the District’s physical setting, formation, organization, operations, and facilities; an inventory of water supplies and uses; a discussion of the District water budget, water management objectives (WMOs), and water use efficiency (WUE); a discussion of potential impacts of climate change and adaptation strategies; an evaluation of the implementation of EWMPs and corresponding WUE improvements; and the District’s drought management plan.

This 2025 AWMP has been updated with all required elements described in the Agricultural Water Management Planning regulations. The AWMP Checklist included at the beginning of

¹ San Joaquin County Agricultural Commissioner’s 2019 Crop Report reports the gross value of all agricultural production in 2019 as \$2,617,815,000.

this Plan provides a cross-reference between the sections of this AWMP and relevant sections of the California Water Code (CWC).

WATER MANAGEMENT OBJECTIVES AND ACTIONS

The District's water management objectives are to:

- Protect and preserve SSJID's water rights.
- Ensure long-term viability of SSJID's water delivery system and enhance flexibility, reliability, and operational efficiency.
- Promote the use of available surface water and protect the sustainable use of groundwater within the District.
- Promote efficient and effective on-farm water use.
- Provide an affordable water supply to SSJID customers.
- Ensure SSJID remains financially sound.
- Promote SSJID's stewardship of the water resource and its local and statewide implications to the economy and the environment.

To these ends, SSJID has conducted and participated in numerous local and regional water management projects and initiatives, in addition to the day-to-day operation and maintenance of the District's supply and distribution system to meet irrigation, domestic, and M&I water demands while also generating hydropower. Actions of note initiated or completed in the last 5 years include the following:

- Initiated efforts to improve water measurement and improved data management including the development of an Advanced Metering Infrastructure (AMI) Program and a rehabilitation and maintenance for District drain sites and gages.
- In 2024, the District updated its Strategic Plan to serve as a road map for the District's continuous improvement towards achieving its adopted Mission, Vision and Values. This Strategic Plan identifies the critical issues facing the District now and into the foreseeable future and proposes actionable solutions to resolve these issues.
- Adoption of the District's 2022 Water Master Plan to prioritize investments in addressing aging infrastructure, modernization of the District's irrigation system, and development of a financing strategy.
- Continuing to partner with the Cities of Ripon and Escalon through the South San Joaquin Groundwater Sustainability Agency (SSJGSA)
- The SSJGSA is one of sixteen member GSAs of the Eastern San Joaquin Groundwater Authority (ESJGWA). The ESJGWA submitted to DWR a single revised Groundwater Sustainability Plan (GSP) for the entire Subbasin in 2022 which was approved by DWR.

- The ESJGWA submitted an Amended 2024 GSP and Periodic Evaluation to DWR in January 2025 and is awaiting review and approval by DWR.
- Developed a semi-automatic water budget tool to support District staff in annual updates to the improved water budget.

Recent drought conditions reemphasize the importance of recharge from surface water supplies for the Eastern San Joaquin Groundwater Subbasin to achieve sustainability, as envisioned the Sustainable Groundwater Management Act of 2014 (SGMA). Analysis shows that seepage and deep percolation of SSJID’s Stanislaus River surface water supply serves as a primary source of recharge to the groundwater system underlying the District. Additionally, surface water delivered by SSJID reduces the need for the District’s irrigation and municipal customers to pump groundwater.

Groundwater levels continue to decline in areas to the east of Stockton and north of SSJID where surface water supplies are limited. A large cone of depression has formed there, so that groundwater flow under SSJID now flows northerly rather than to the west. Extended drought or other circumstances which limit surface water supplies are likely to exacerbate this condition. SSJID through the SSJGSA works collaboratively with other GSAs to support implementation of the GSP and to comply with groundwater recharge targets required by SGMA. SSJID will continue to work with local GSAs to achieve long-term groundwater sustainability by implementing projects to maximize local water supplies, enhance conjunctive management practices, and recharge the groundwater system. In the event projects and management actions do not result in groundwater sustainability, SSJID will support local GSAs in their efforts to reduce groundwater pumping demands.

IMPLEMENTATION OF EFFICIENT WATER MANAGEMENT PRACTICES

CWC §10608.48 lists sixteen EWMPs aimed at promoting efficient water management. According to SBx7-7, two of these are “critical” or mandatory, and the remaining fourteen “conditional” EWMPs are to be implemented if technically feasible and locally cost effective. Of the fourteen conditional EWMPs, SSJID is implementing all of those that are technically feasible at locally cost effective levels. The EWMPs, along with past and future implementation activities by SSJID are described in Table ES-1.

CONCLUSION

Development of this AWMP has provided SSJID with an opportunity to evaluate and describe its ongoing water management activities and to evaluate how these actions support the District’s water management objectives, described above, as well as water use efficiency improvements from the State’s perspective. As demonstrated in the Plan, SSJID is a local leader in water management and is committed to the ongoing evaluation and implementation of water management practices that meet water management objectives. In the future, SSJID will continue efforts to effectively manage available surface water and groundwater supplies.

Internationally Left Blank

Table ES-1. Summary of EWMP Implementation Status

Water Code Reference No.	EWMP	Position	Implemented Activities	Planned Activities
Critical (Mandatory) Efficient Water Management Practices				
10608.48.b(1)	Measure the volume of water delivered to customers with sufficient accuracy	Being Implemented	<p>As of 2024, more than 310 magnetic flow meters have been installed in SSJID, including 77 meters in the Irrigation Enhancement Project area and more than 233 meters installed elsewhere in the system. Outside of the Irrigation Enhancement Project area, farm deliveries without magnetic meters are currently measured by rated gates or, in some cases, by determining the difference in flow between stand structures in the lateral upstream and downstream of the farm turnout.</p> <p>In 2024, the District applied for a Water and Energy Efficient Grant under the Bureau of Reclamation’s WaterSmart Program to fund an Advanced Metering Infrastructure (AMI) meter replacement program and interactive platform using telemetry to report water meter data to the District. The District also intends to make the data available to growers in near real time. The costs to purchase and install the new water meters and telemetry are estimated to be more than \$4 million with additional ongoing maintenance and replacement costs. District will update the corrective action plan as needed to achieve timely compliance with the accuracy standards of 23 CCR §597.</p>	
10608.48.b(2)	Adopt a pricing structure based at least in part on quantity delivered	Being Implemented	<p>In 2023, the District raised its irrigation rates through a successful Proposition 218 effort. SSJID’s current rate structure has two tiers of volumetric pricing for growers that receive non-pressurized water service. For the 2026 irrigation season, a fixed acreage charge of \$60 per acre charge plus an additional volumetric charge. Growers that receive less than 48 inches per year are charged the ‘Tier 1’ rate, with a volumetric charge of \$10 per af. Growers pay the ‘Tier 2’ rate of \$17.50 per af for any water diverted over 48 inches per year.</p> <p>Parcels that receive pressurized water from the District’s Division 9 Irrigation Enhancement Project are subject to the fixed acreage charge and volumetric charges plus the Pressurized Irrigation Rate of \$58.12 per acre-foot..</p>	
Additional (Conditional) Efficient Water Management Practices				
10608.48.c(1)	Facilitate alternative land use for lands with exceptionally high water duties or whose irrigation contributes to significant problems, including drainage.	Not Technically Feasible	<p>"Lands with exceptionally high water duties or whose irrigation contributes to significant problems" are not known to exist within the SSJID service area. District Rule #10 in the rules and regulations governing the distribution of water within SSJID prohibit the wasteful use of water through the "...flood[ing] of certain portions of the land to an unreasonable depth or amount." Additionally, facilitation of alternative land use is beyond SSJID's jurisdiction; however, SSJID assists customers in implementing on-farm conservation measures, as described under EWMP 4.</p>	
10608.48.c(2)	Facilitate use of available recycled water that otherwise would not be used beneficially, meets all health and safety criteria, and does not harm crops or soils	Being Implemented	<ol style="list-style-type: none"> 1. M&I wastewater from City of Manteca applied directly to SSJID irrigated lands. 2. No additional available recycled water exists within the District service area that is not already feasibly beneficially used. 3. Ripon currently uses recycled water for irrigation of city parks and landscaping. 	<ol style="list-style-type: none"> 1. Continue existing use of recycled water within SSJID. 2. Consider requests from all qualifying permitted dischargers for additional use of recycled water.
10608.48.c(3)	Facilitate financing of capital improvements for on-farm irrigation systems	Being Implemented	<ol style="list-style-type: none"> 1. The District has suspended its On-farm Program. 2. The District is implementing an aggressive CIP since adoption of the SSJID WMP in 2022. 	<ol style="list-style-type: none"> 1. Continue facilitating and supporting on-farm improvements through SWEEP Grant Program as funds are available 2. Potentially continue the On-Farm Conservation Program as soon as funds become available.

Water Code Reference No.	EWMP	Position	Implemented Activities	Planned Activities
10608.48.c(4)	Implement an incentive pricing structure that promotes one or more of the following goals: (A) More efficient water use at farm level, (B) Conjunctive use of groundwater, (C) Appropriate increase of groundwater recharge, (D) Reduction in problem drainage, (E) Improved management of environmental resources, (F) Effective management of all water sources throughout the year by adjusting seasonal pricing structures based on current conditions.	Being Implemented	<ol style="list-style-type: none"> 1. SSJID’s volumetric charge promotes more efficient water use at the farm level and discourages excessive drainage (goals A and D). 2. Current pricing maintains low rates for surface water to promote conservation of groundwater through in lieu and direct recharge (goals B and C). 3. SSJID’s Irrigation Enhancement Project incentivizes more efficient irrigation systems and increases groundwater recharge in lieu and direct recharge (goals A through D). 4. Conservation Program increases use of surface water and efficient irrigation practices by encouraging growers who aren’t District members to join to become eligible for incentives (goals A through D). 	<ol style="list-style-type: none"> 1. The District will review and assess its volumetric charge over time to ensure that identified water management objectives are being achieved.
10608.48.c(5)	Expand line or pipe distribution systems, and construct regulatory reservoirs to increase distribution system flexibility and capacity, decrease maintenance and reduce seepage	Being Implemented	<ol style="list-style-type: none"> 1. Main Canal is mostly unlined but provides beneficial groundwater recharge through seepage. 2. Maintain 312 miles of pipeline. 3. Maintain 38 miles of lined channel. 4. Maintain 18 miles of unlined channel. 5. Scheduled maintenance and/or replacement of infrastructure. 6. Constructed Van Groningen Reservoir in 1992. 7. Constructed 5-acre SIDE reservoir and cross-lateral intertie pipeline in 2003. 8. Constructed 7-acre Sam Bologna Reservoir as part of the Irrigation Enhancement Project (also known as the Division 9 Project), completed in 2012. 9. Replaced approximately 5.8 miles of old pipeline between 2015 and 2020. 10. Reline (shotcrete) 3,000 to 4,000 LF of ditch per year. 11. Initiated trenchless pipe re-lining program with a target re-lining rate of 21,000 LF per year. In 2025-2026, SSJID crews accomplished 15,500 LF of pipe relining at a cost of ~\$90 per LF. 	<ol style="list-style-type: none"> 1. Strive to reach 24,000 LF per year Pipe Relining target. 2. Continue Maintenance Program. 3. Seek grant funding for Q-Qc Reservoir Project.

Water Code Reference No.	EWMP	Position	Implemented Activities	Planned Activities
10608.48.c(6)	Increase flexibility in water ordering by, and delivery to, water customers within operational limits	Being Implemented	<ol style="list-style-type: none"> 1. Ongoing efforts to facilitate high frequency, low volume deliveries to pump customers using pressurized irrigation systems. 2. Irrigation Enhancement Project (also known as the Division 9 project) completed in 2012 provides pressurized water on an arranged demand basis to a current total of 77 customers (as of 2020) while also enhancing delivery service for remaining surface irrigators. 3. On-Farm Conservation Program helped improve District-grower coordination. 4. Canal automation and construction of regulating reservoirs and intertie pipelines enhances flexibility and steadiness, especially to growers near the lower ends of the system. 5. Implementation of SCADA and TruePoint enhances DMs' ability to track and manage flows through the distribution system and deliveries to customers, improving delivery efficiency and flexibility 6. Conceptual plan to modernize the District's Water Information System (WIS) completed in 2020, will also improve the District's ability to efficiently track and manage flows and deliveries 7. Infrastructure improvements to enhance delivery flexibility to customers, especially those using sprinkler and microirrigation systems and those served along "dead-end" laterals: <ol style="list-style-type: none"> a. Pour-over wall (weir) modifications in pipeline control box structures. b. Float valve, automated gates, and remote water level sensor installations for automatic flow regulation and downstream level control. 	<ol style="list-style-type: none"> 1. Improve the level of service consistent with the SSJID WMP. 3. Evaluate continued funding of On-Farm Conservation Program on a year-to-year basis. 4. Seek grant for Advanced Metering Infrastructure 5. Continue infrastructure improvements to enhance delivery flexibility to customers, especially those using sprinkler and microirrigation systems and those served along "dead-end" laterals: <ol style="list-style-type: none"> a. additional pour-over wall (weir) modifications b. additional float valve, automated gates, and remote water level sensor installations 6. Evaluate and implement additional locally cost-effective actions to improve flexibility
10608.48.c(7)	Construct and operate supplier spill and tailwater recovery systems	Being Implemented	<ol style="list-style-type: none"> 1. SCADA at all drop structures along the MDC provides real-time control to prevent spillage. 2. The Van Groningen Reservoir provides for collection and storage of spillage and re-regulation. 3. The East Basin Reservoir in the Irrigation Enhancement Project area captures spillage nearby divisions. 4. Campbell Drain (Division 2) collects operational spillage and tailwater and conveys it into the "B" lateral in Division 3 for reuse. 5. Where tailwater drains do not exist, growers may channel tailwater back into District pipelines for redistribution. 6. Intertie pipeline construction for redistribution of excess. 7. Accept tailwater at 36 locations along the upper portions of the MSC and MDC, including spillage and tailwater outflows from OID 8. Continued and expanded monitoring at spill sites to reduce spillage and develop representative data. 	<ol style="list-style-type: none"> 1. Rehabilitate and replace all drain monitoring sites to reduce spillage and develop representative data. 2. Install flow meter at FCOC to measure water leaving the system. 3. Find grant funding for identified WMP opportunities to expand tailwater and spillage prevention and recovery capabilities.
Water Code Reference No.	EWMP	Position	Implemented Activities	Planned Activities

Water Code Reference No.	EWMP	Position	Implemented Activities	Planned Activities
10608.48.c(8)	Increase planned conjunctive use of surface water and groundwater within the supplier service area	Being Implemented	<ol style="list-style-type: none"> 1. Encourage use of available surface water supplies in lieu of groundwater through construction of pressurized irrigation systems. 2. Provide surface water at a lower cost than pumping groundwater. 3. Utilize more than 20 groundwater wells to augment surface water supplies and control shallow groundwater levels. 4. Constructed Irrigation Enhancement Project to provide pressurized surface water for irrigation to a current total of 77 customers (as of 2020) through 19 miles of pipelines serving approximately 3,800 acres. 5. Ongoing deliveries of surface water to the Nick D. DeGroot WTP, where it is treated and used to supply municipal water demands through cities participating in the SCWSP. 5. Active participation in local groundwater entities and initiatives, including the SSJGSA, ESJGWA, and the Eastern San Joaquin Subbasin Groundwater Subbasin Sustainability Plan 6. Constructed two groundwater wells to supplement water supply for East Basin. 	<ol style="list-style-type: none"> 1. Continue to support GSP implementation activities and annual reporting. 2. Continue to encourage conjunctive use in agriculture by supplying pressurized irrigation service, and by supplying surface water at a lower rate than the cost of pumping groundwater. 3. Continue to encourage conjunctive use in urban areas through the SCWSP
10608.48.c(9)	Automate canal control structures	Being Implemented	<ol style="list-style-type: none"> 1. Automation of all 24 lateral headings and all control structures on the MSC and MDC to improve customer service while reducing system losses. 2. Automation of the SIDE reservoir to maintain steady water supply to three adjacent laterals. 3. Implementation of an extensive SCADA system to provide communication, monitoring, and control of automated sites, including remote on/off control of 28 groundwater wells. 4. Automation of 19 miles of pipelines and deliveries to a current total of 77 customers (as of 2020) in the Irrigation Enhancement Project. 5. Infrastructure improvements to enhance canal automation: <ol style="list-style-type: none"> a. installation of new automated gates (Rubicon SlipMeters, etc.), including one at Valley Home Drop. b. installation of float valves, automated gates, and remote water level sensor for automatic flow regulation and downstream level control. 	<ol style="list-style-type: none"> 1. SSJID will continue to evaluate opportunities for additional automation to increase delivery flexibility and steadiness and to reduce operational spillage. 2. Continue infrastructure improvements to enhance canal automation: <ol style="list-style-type: none"> a. planned installation of 16 new automated gates (Rubicon SlipMeters, BladeMeters, etc.) b. planned installation of float valves at 17 locations for automatic flow regulation and support of downstream level control. 3. Upgrade and replace aging SCADA and automation infrastructure on the MDC.
10608.48.c(10)	Facilitate or promote customer pump testing and evaluation	Being Implemented	<ol style="list-style-type: none"> 1. SSJID facilitates and promotes customer pump testing and evaluation by providing links on its website to programs that provide these services, such as offered by PG&E (http://www.pumpefficiency.org/). 	<ol style="list-style-type: none"> 1. Continue facilitating and promoting customer pump testing programs. 2. Consider cost sharing for pump efficiency testing as part of its On-farm Water Conservation Program, if reinstated.
10608.48.c(11)	Designate a water conservation coordinator who will develop and implement the water management plan and prepare progress report.	Being Implemented	<ol style="list-style-type: none"> 1. SSJID added a permanent, full time water conservation coordinator in 2011. 	<ol style="list-style-type: none"> 1. Continue to employ a full time water conservation coordinator.

Water Code Reference No.	EWMP	Position	Implemented Activities	Planned Activities
10608.48.c(12)	Provide for the availability of water management services to water users.	Being Implemented	<ol style="list-style-type: none"> 1. SSJID provides for the availability of water management services through scientific irrigation scheduling and soil moisture monitoring conservation measures, for example, as part of its On-Farm Water Conservation Program. 2. Links to CIMIS and other water management information available on District website. 3. Periodic irrigation newsletter produced and distributed to growers, staff, and the public. 4. Educational materials and resources available to farmers, staff, and the public through the District's website. 5. Educational opportunities and presentations offered to the public by District staff. 6. Historical water use data is available to growers in the Irrigation Enhancement Project (also known as the Division 9 project). 7. In 2015, Drought Task Force aided growers in improving on-farm irrigation efficiencies. 8. Made regular water usage information available online to growers (since 2013). 9. Made on-farm meter readings available to growers online through web portal (since 2018). 10. Added SCADA to 160 magnetic flow meters. 	<ol style="list-style-type: none"> 1. Continue current activities. 2. Provide regular water usage information as part of implementing volumetric billing. 3. Continue adding SCADA monitoring to magnetic flow meters measuring farm deliveries.
10608.48.c(13)	Evaluate the policies of agencies that provide the supplier with water to identify the potential for institutional changes to allow more flexible water deliveries and storage.	Being Implemented	<ol style="list-style-type: none"> 1. SSJID actively evaluates the effect of supplier (Reclamation) and Tri-Dam Project policies and operational practices and seeks policy changes to alleviate water supply constraints. 2. SSJID actively participates in SGMA-related entities and efforts (SSJGSA, ESJGWA, implementation of the Eastern San Joaquin Groundwater Subbasin GSP). 	<ol style="list-style-type: none"> 1. Continue current activities.
10608.48.c(14)	Evaluate and improve the efficiencies of the supplier's pumps.	Being Implemented	<ol style="list-style-type: none"> 1. Periodic evaluation and improvements of pumps by performing periodic pump efficiency tests to identify cost effective energy and/or water conservation improvements. 2. Maintain more than 20 GW pumps. 3. Maintain 7 pumps at the East Basin Reservoir and 5 at the SIDE Reservoir. 	<ol style="list-style-type: none"> 1. Continue testing and periodic refurbishment or replacement of pumps and motors. 2. Add any new pumps to the existing testing program. 3. Rebuild deep well operating at 30 percent efficiency.

Intentionally Left Blank

1 INTRODUCTION

This Agricultural Water Management Plan (AWMP or Plan) has been prepared by the South San Joaquin Irrigation District (SSJID or District) to describe the District’s leadership in agricultural water management. Established in 1909, SSJID has provided reliable irrigation water service to its customers in southern San Joaquin County. SSJID’s goal remains the same today: “It is the desire and intention to carry on the business of the District in a businesslike and economical manner to secure the greatest good to the greatest number.” (SSJID Rules and Regulations 1919).

This section provides a description of the District’s rich history of regional water management spanning more than 115 years, a description of legislative requirements related to the contents of the Plan, and a summary of previous water management activities. The District’s primary water management objective is to maintain a reliable, affordable, high quality water supply for agriculture and other uses. Water for irrigation is foundational to supporting agriculture, the economic engine of San Joaquin County. In 2024, over \$3.14 billion in agricultural commodities were produced in the County². Key strategies employed by SSJID to support overall water management objectives are the conjunctive management of surface and groundwater supplies and water conservation.

Section 2 describes the process of preparing the Plan, including public outreach efforts. Section 3 provides a detailed background describing SSJID, its facilities, and the irrigation service area. Section 4 provides an inventory of SSJID’s water supplies, which is followed in Section 5 with presentation of detailed water balances for the 2005 to 2024 period. Water balances are presented for six primary accounting centers that represent the District’s distribution system and agricultural service area:

- Main Supply Canal (MSC) Above Woodward Reservoir
- Woodward Reservoir
- MSC Below Woodward Reservoir and Main Distributary Canal (MDC)
- District Laterals
- Irrigated Lands
- Drainage System

Potential climate change effects on weather and hydrology, impacts on water supplies, and adaptation strategies are discussed in Section 6. Section 7 describes SSJID’s implementation of Efficient Water Management Practices (EWMPs) and includes an evaluation of EWMP implementation relative to SSJID’s Water Management Objectives (WMOs) and Water Use Efficiency (WUE) improvements in general.

² San Joaquin County Agricultural Commissioner’s 2024 Crop Report reports the gross value of all agricultural production in 2024 as \$3,146,586,502.

This AWMP has been prepared in accordance with the requirements of Assembly Bill (AB) 1668 (May 31, 2018), the Water Conservation Act of 2009 (SBx7-7), and Agricultural Water Measurement Requirements under Title 23 of the California Code of Regulations (CCR), §597 *et seq.*, 2011.

1.1 SSJID HISTORY

SSJID was formed in 1909, and in 1910 co-purchased one-half interest each in certain Stanislaus River water rights and facilities from two existing water companies. SSJID's sister district, Oakdale Irrigation District (OID), holds the other half of the options to the rights and deeds. Thereafter, the Districts initiated expansion of their both shared storage and conveyance facilities as well as individually pursued their own improvement to their respective distribution systems. Collectively, OID and SSJID jointly hold pre-1914 water rights for diversion of up to 1,816.6 cfs from the Stanislaus River at Goodwin Dam.

Construction of New Melones Reservoir and Dam (completed in 1979, Figure 1-1) replaced the original Melones Lake and Dam, and operation was transferred to the U.S. Bureau of Reclamation (USBR), impacting the ability of the districts to store and divert water despite their senior water rights. In 1988, SSJID and OID entered into an operational agreement with USBR recognizing and protecting the rights of the districts. This agreement sets season limits on the quantity and timing of diversions by SSJID. The agreement also provides the districts with the first 600,000 acre-feet (af) of inflow to New Melones annually as a first priority, with special provisions in drought years. Inflow to New Melones represents one of the most reliable water supplies in California.



Figure 1-1. New Melones Dam

With a secure and reliable water supply, SSJID has invested in infrastructure improvements and the maintenance of District's facilities over the last 115 years. Leadership and action by the Board of Directors and staff have maintained the integrity of the District's operational philosophy of providing high quality water for irrigation at affordable prices and have proactively sought physical and operational improvements to enhance irrigation service. SSJID is embarking on efforts to plan for the actions necessary to maintain and continue to enhance service while protecting local water supplies for generations to come.

Over the long history of irrigation in SSJID, cropping patterns have shifted from forage and feed crops grown to support dairy and livestock operations in the region to more permanent orchard and vine crops. Approximately 82.1% of the irrigated acreage within SSJID (as of 2025) are permanent crops. Predominantly, almonds represent approximately 69.4% of the cropped acreage in SSJID. A variety of other crops are also grown including wine grapes, corn, pasture, grains, alfalfa, berries, melons, and stone-fruits. The SSJID distribution system infrastructure and operating policies have evolved over time to satisfy the needs of permanent tree crops, and are still generally adequate to meet those needs. However, improved water delivery strategies are needed to satisfy the evolving irrigation needs of orchards and other specialty crops, particularly as they transition from surface irrigation methods to pressurized irrigation methods (micro-irrigation and sprinklers).

1.2 PREVIOUS WATER MANAGEMENT ACTIVITIES IN SSJID

The SSJID Board and management recognize that continued assessment and updates of the District's policies, procedures, and facilities are needed. As a result, SSJID has initiated and completed several foundational efforts since the 1980s to support long term infrastructure planning. Actions of note initiated or completed in the last 5 years include the following:

- Initiated efforts to improve water measurement and improved data management including the development of an Advanced Metering Infrastructure (AMI) Program and a rehabilitation and maintenance for District drain sites and gages.
- In 2024, the District updated its Strategic Plan to serve as a road map for the District's continuous improvement towards achieving its adopted Mission, Vision and Values. This Strategic Plan identifies the critical issues facing the District now and into the foreseeable future and proposes actionable solutions to resolve these issues.
- Adoption of the District's 2022 Water Master Plan to prioritize investments in addressing aging infrastructure, modernization of the District's irrigation system, and development of a financing strategy.
- Continuing to partner with the Cities of Ripon and Escalon through the South San Joaquin Groundwater Sustainability Agency (SSJGSA)
- The SSJGSA is one of sixteen member GSAs of the Eastern San Joaquin Groundwater Authority (ESJGWA). The ESJGWA submitted to DWR a single revised Groundwater Sustainability Plan (GSP) for the entire Subbasin in 2022 which was approved by DWR.
- The ESJGWA submitted an Amended 2024 GSP and Periodic Evaluation to DWR in January 2025 and is awaiting review and approval by DWR.
- Developed a semi-automatic water budget tool to support District staff in annual updates to the improved water budget.

Actions of note initiated or completed in the last 15 years include the following:

- Initiated planning for a Water Information System (WIS) and prepared a conceptual plan to develop the WIS to improve data management.
- Developed a semi-automatic water budget tool to support District staff in annual updates to the improved water budget.
- As of 2024, installed more than 310 magnetic flow meters (77 in the Irrigation Enhancement Project area, more than 233 elsewhere in the District), at a cost of approximately \$6,000 each. These meters measure water deliveries to customers and SCADA has been installed on 160 magnetic flow meters (60 since 2015) at a cost of \$4,200 each. SCADA transmits the water measurement data to the District Control Room
- Partnered with Ripon and Escalon to form the South San Joaquin Groundwater Sustainability Agency (SSJGSA)
- Through the SSJGSA, joined with other GSAs to form the East San Joaquin Groundwater Authority (ESJGWA) to develop a single Groundwater Sustainability Plan (GSP) for the Subbasin that was submitted to DWR ahead of the January 31, 2020 deadline.
- Funded a feasibility study to assess the costs and benefits of providing District-wide pressurized service, similar to that provided by the Irrigation Enhancement Project (also known as the Division 9 Project).
- Participated in the San Joaquin County Integrated Regional Water Management Plan.
- Developed storm drainage agreements with Manteca and Escalon that provide enhanced safeguards with regard to water quality and quantity standards for water that enters the District's distribution and drainage systems.
- Completion of the Irrigation Enhancement Project (also known as the Division 9 Project) in 2012, resulting in the availability of pressurized water for irrigators with arranged demand and online ordering, also reducing reliability on groundwater of lesser quality.
- Development and implementation of SSJID's On-Farm Water Conservation Program in 2011, providing direct incentives to SSJID irrigators to utilize available surface water supplies while implementing water conservation practices.
- In 2011, the District licensed its own Federal Communications Commission (FCC) frequency and built eight (8) microwave towers to support the enhancement of its Supervisory Control and Data Acquisition (SCADA) system.
- Installation and implementation of TruePoint water ordering software in 2009 to improve accounting of individual customer deliveries and support volumetric water charges.

- Acceleration of capital improvement projects from 2008 through 2010 to create local jobs and to take advantage of reduced construction costs.
- Development and implementation of a Flow Measurement Plan in 2010, including phased measurement improvements at boundary outflows, delivery measurement accuracy assessment, and pilot testing of delivery measurement alternatives.
- Preparation of a Joint Canal hazard study and completion of tunnel improvements on the Joint Canal and Upper Main Supply Canal between 2005 and 2010 totaling approximately \$5 million.
- Development of a 15 year water balance for 1994 to 2008 in 2009, providing a benchmark of recent historical water use within the District to allow for assessment of current water management and planning and evaluation of future improvements.
- Development of the South County Water Supply Program (SCWSP) through a collaborative and cooperative effort between SSJID, Manteca, Escalon, Lathrop and Tracy to provide treated surface water to supplement the cities' existing groundwater supply through the construction of the Nick C. DeGroot Water Treatment Plant (WTP), including 37 miles of transmission pipeline that also supplies the Cities of Manteca, Lathrop and Tracy. Since it was commissioned in 2005, approximately 17,000 af has been delivered each year from Woodward Reservoir to the WTP for treatment and delivery to the cities currently under contract. In 2021, the WTP delivered 24,214 af , the highest annual production since its commissioning, and operates at or near capacity during peak demand months. The opportunity to provide supplemental water to municipalities was made possible through SSJID's extensive conservation and water management efforts in the 1980s and 1990s that resulted in significant reductions in spillage and increased system efficiency. These improvements increased flexibility and reliability in the delivery of water for irrigation.
- Development and implementation of the System Improvements for Distribution Efficiency (SIDE) project in 2003, resulting increased flexibility for system operations and deliveries in the surrounding area.

Additionally, the District has completed several projects related to Woodward Reservoir, including hydrologic, capacity, and dam safety studies as well as various improvements to reduce reservoir losses.

1.3 OTHER WATER MANAGEMENT ACTIVITIES

In addition to this AWMP and the specific activities listed above, SSJID has a long history of involvement with various other water management activities at local, regional, and state levels. These activities include the following:

- **Eastern San Joaquin Groundwater Authority (<http://www.esjgroundwater.org/>).** SSJID, as part of the South San Joaquin Groundwater Sustainability Agency (SSJGSA), is a member of the Eastern San Joaquin Groundwater Authority (ESJGWA). The ESJGWA was established in response to the Sustainable Groundwater Management Act of 2014 (SGMA), and functions to organize, coordinate, and execute SGMA compliance efforts among the 16 GSA members in the Eastern San Joaquin Subbasin to achieve groundwater sustainability by 2040. SSJID’s involvement in the SSJGSA and the ESJGWA has contributed towards the adoption and submittal of the 2022 Revised Groundwater Sustainability Plan (GSP) which was approved by DWR. The ESJGWA submitted an Amended 2024 GSP and Periodic Evaluation to DWR in January 2025 and is awaiting review by DWR.
- **San Joaquin County & Delta Water Quality Coalition (www.sjdeltawatershed.org).** The District is a member of the San Joaquin County and Delta Water Quality Coalition under the Irrigated Lands Regulatory Program of the State Water Resources Control Board. The San Joaquin County & Delta Water Quality Coalition was established to help irrigated agriculture meet the requirements of the California Regional Water Quality Control Board's (RWQCB) Irrigated Lands Regulatory Program (ILRP) in San Joaquin County, Calaveras County and Contra Costa County. Under the ILRP that was originally adopted in July of 2003, farmers and ranchers that irrigate their land and have runoff from that irrigation or rainfall must belong to a coalition or apply for an individual discharge permit from the Regional Board directly. Prior to joining the coalition in 2010, SSJID filed as an individual discharger under the program and collected its own water quality information beginning in 2004.
- **Tri-Dam Project and Power Authority (www.tridamproject.com).** The Tri-Dam Project is a partnership between SSJID and OID that developed and now operates and maintains Donnell's and Beardslee Reservoirs above New Melones Reservoir and Tulloch Reservoir below on the Stanislaus River. The reservoirs are operated for irrigation water supply and power generation, as well as for recreation and water sports. Tri-Dam Power Authority is a joint powers authority of SSJID and OID that owns and operates the Sand Bar power generation plant above New Melones Lake.
- **San Joaquin Tributaries Authority (sjtribs.org).** The San Joaquin Tributaries Authority is a coalition of SSJID with Modesto Irrigation District, Turlock Irrigation District, and the City and County of San Francisco with the mission of advancing collaborative, sustainable water management and flood control while providing dependable water supplies for agriculture, the environment, and the communities we serve. .

Internationally Left Blank

2 PLAN PREPARATION

2.1 AWMP PREPARATION

This AWMP is the April 1, 2025 update to the SSJID AWMP, last adopted and submitted to DWR in 2021 in accordance with SBx7-7. As described previously, this AWMP has been prepared in accordance with the requirements of Assembly Bill (AB) 1668 (May 31, 2018), the Water Conservation Act of 2009 (SBx7-7), and Agricultural Water Measurement Requirements under Title 23 of the California Code of Regulations (CCR), §597 *et seq.*, 2011. This updated 2025 AWMP must be adopted and submitted to DWR by May 1, 2026.

2.2 PUBLIC PARTICIPATION

Public participation in the development of this Plan included the following actions. Sample notices, letters, and publication materials are provided in Appendix G.

- On March 24, 2026, the District Board of Directors approved the Notice of Public Hearing setting the Public hearing date for 9:00 A.M., April 7, 2026 prior to the adoption of the 2025 AWMP
- On March 24, 2026, the District sent a letter notifying the Counties of San Joaquin and Stanislaus, and the Cities of Manteca, Ripon, Escalon, Tracy, and Lathrop of the preparation and impending adoption of the 2025 AWMP;
- On March 31st and April 7th, 2026, the District published a legal Notice of Public Hearing to Adopt the 2025 AWMP in the Manteca Bulletin per Government Code Section 6066;
- The District posted the Draft 2025 AWMP to the District’s web page (www.ssjid.gov) for public review on March 31, 2026 with instructions for reviewers to submit comments and ask questions. The District subsequently posted corrected versions of the Draft 2025 AWMP prior to the Public Hearing;
- On April 14, 2026, District staff presented a summary of the 2025 AWMP to the Board of Directors. The Board of Directors subsequently held the Public Hearing and adopted the 2025 AWMP;
- Before May 1, 2026, District staff submitted the adopted 2025 AWMP to the Department of Water Resources (DWR) through the Water Use Efficiency Data Portal at (www.wuedata.water.ca.gov);
- Provision of copies of the adopted AWMP to the following parties within 30 days of adoption:
 - Counties of San Joaquin and Stanislaus

- Cities of Manteca, Ripon, Escalon, Tracy, and Lathrop
- San Joaquin County Library
- Local Agency Formation Commission (LAFCo) of San Joaquin County
- California State Library (cslgps@library.ca.gov)
- Eastern San Joaquin Groundwater Authority
- The public, via the SSJID website

The public is invited to attend all Board meetings with time reserved on each agenda for public comments. The Board members are accessible to the public. The District has a web site (www.ssjid.com) where the agendas of all Board meetings are published along with the most recent Board minutes, newsletters and other important information. Comments can be submitted via e-mail.

The District distributes a newsletter periodically to publicize important issues. The District maintains an open exchange of information with local newspapers and issues press releases on matters of importance to the public. The District also relies on its Division Managers (DMs) to keep customers informed of the latest water management information.

2.3 REGIONAL COORDINATION

The District coordinates operation of the Tri-Dam Project cooperatively with OID and coordinates with neighboring agencies, as appropriate; however, SSJID does not plan to develop a regional AWMP at this time due to differences in the institutional, physical, and operational characteristics of each district.

2.4 PLAN IMPLEMENTATION

SSJID has taken many actions to promote efficient water management throughout its more than 115 year history. Today, SSJID continues to evaluate and implement additional measures to accomplish improved and more efficient water management, according to the District's water management objectives. For purposes of this AWMP, SSJID water management actions have been organized and are reported with respect to the Efficient Water Management Practices (EWMPs) listed in CWC §10608.48.

A summary of the past and planned implementation efforts for this AWMP are described in Section 7 of this AWMP, outlined according to the EWMPs that these efforts support (Tables ES-1 and 7-5). Other efforts specifically related to drought are described in the District's Drought Management Plan (Appendix D). Drought resilience efforts are implemented in all years, while drought response efforts are implemented in years of water shortage by the District's Board of Directors.

3 BACKGROUND AND DESCRIPTION OF SERVICE AREA

3.1 FORMATION

SSJID was organized in 1909 under the California Irrigation District Act – originally called the “Wright Act” – which provided for the organization of irrigation districts, for the acquisition or construction of irrigation facilities, and for the distribution of water for irrigation purposes. The Wright Act was approved March 31, 1897 (Statutes 1897, p. 254 et seq.).

The ditch system that later gave birth to SSJID and OID was developed by miners in 1855 as a means to divert water from just above the current location of Goodwin Dam for mining and domestic water supply in areas around Knights Ferry (Marvin, 2006). The San Joaquin County Water Company later acquired the diversion rights and the existing “Knights Ferry Ditch” and made efforts to expand the ditch system to the west for irrigation. Foreclosure prompted the sale of the rights to a local landowner named Abraham Schell in 1856. In 1888, Mr. Schell relinquished ownership to the newly formed San Joaquin Land and Water Company who, as early as 1864, had planned to extend the ditches and build a county-wide distribution system that would supply both water and power. Construction and funding for the enterprise proved to be difficult. With approximately \$170,000 already spent on construction, tensions amongst the Company prompted the stockholders to relinquish ownership to H.W. Cowell and his partner, N.S. Harrold, who both owned the Stanislaus and San Joaquin Water Company. Being large landowners, Cowell and Harrold were interested in developing a reliable water supply for irrigation and other uses and had the necessary capital to undertake the massive project of tunnel, ditch, dike, and flume construction.

Between 1888 and 1905, the ditch system was extended southwesterly towards modern-day Lathrop, in part by way of Lone Tree Creek, and northerly through Little Johns Creek toward Farmington. The ditch system irrigated approximately 6,000 acres in what is now SSJID, as well as small landholdings near Oakdale (Greene, 1895). Although there were many important figures involved in developing the system, much of the system’s expansion and eventual success can be traced back to Mr. Charles Tulloch.

In the early 1860s the Tulloch Family, who owned a flour mill in Knights Ferry, acquired the upper portions of the original Knights Ferry Ditch to power their mill and constructed a new diversion dam just below the existing Tulloch Dam. Charles Tulloch was an early member of the San Joaquin Land and Water Company and saw great potential in controlling the water supply for irrigation and electrical generation. With the ownership of the Knights Ferry Ditch, Mr. Tulloch built the first hydroelectric powerhouse on the Stanislaus River and incorporated the Stanislaus Water and Power Company to supply power to Knights Ferry, Oakdale, and rural Modesto. In 1899, Mr. Tulloch and three other prominent local businessmen and landowners organized the Stanislaus Water Company and purchased the entire Knights Ferry Ditch, including all water rights and partially completed facilities, from the financially troubled

Stanislaus and San Joaquin Water Company at auction for \$27,300. The Company expanded the ditch length to reach near Lathrop, increased its capacity, and installed improved concrete infrastructure. Under the Tulloch Family interests, the ditch system continued to supply irrigation and domestic water services under the South San Joaquin Canal and Irrigation Company and the Consolidated Stanislaus Water and Power Company.

The limited capacity of the “Tulloch Ditch” was not enough to supply the growing demand for water, and landowners were not willing to fund the construction of a larger system if the water rights were privately held. In March of 1909, local landowners Joshua Cowell, F.A. West, and P.E. Lunstrom petitioned the San Joaquin County Board of Supervisors to form the South San Joaquin Irrigation District under the Wright Act, and to authorize a bond issue of \$1,875,000. This funding would be used to purchase the Tulloch Ditch and to start the construction of new, larger infrastructure to supply the roughly 70,000 acres that the District would encompass. An election was held on May 11, 1909, in which voters overwhelmingly supported formation of the District (396 to 67) and elected the first Board of Directors (German, 1942).

After the task of legal formation was complete, the Board of Directors adopted a plan for constructing the necessary canals and works, and for acquiring the necessary property and rights to carry out the provisions of the act under which it was created. Additional bond issues were called for by the Board during the initial construction of the system and again during the first few years of operation. The Board also had the power to levy taxes and land assessments within the service area to pay for expenses and to repay the bonds.

A more detailed description of the history of the development of the District’s surface water supply is provided in Section 4: Inventory of Water Supplies.

3.2 DISTRICT ORGANIZATION

SSJID’s elected Board of Directors is responsible for setting policy and organizational direction on behalf of its constituents. The District is organized into five divisions, with each division represented by one director (Figure 3-1). Directors are elected for a four-year term by the registered voters residing within the division. Elections are held every two years so that terms are staggered and only two or three of the directors’ seats are subject to election at any one time. The Board of Directors elects a Board President to run the District’s board meetings, and a Vice-President to serve if the Board President is unavailable. The Board President serves for a two-year term. The Board meets at least twice a month on the second and fourth Tuesdays of the month. Other meetings may be scheduled as needed during the month.

SSJID’s five directors also serve as board members on the Tri-Dam Project’s Joint Board of Directors, and as commissioners of the Tri-Dam Power Authority Board, together with the OID Board of Directors.

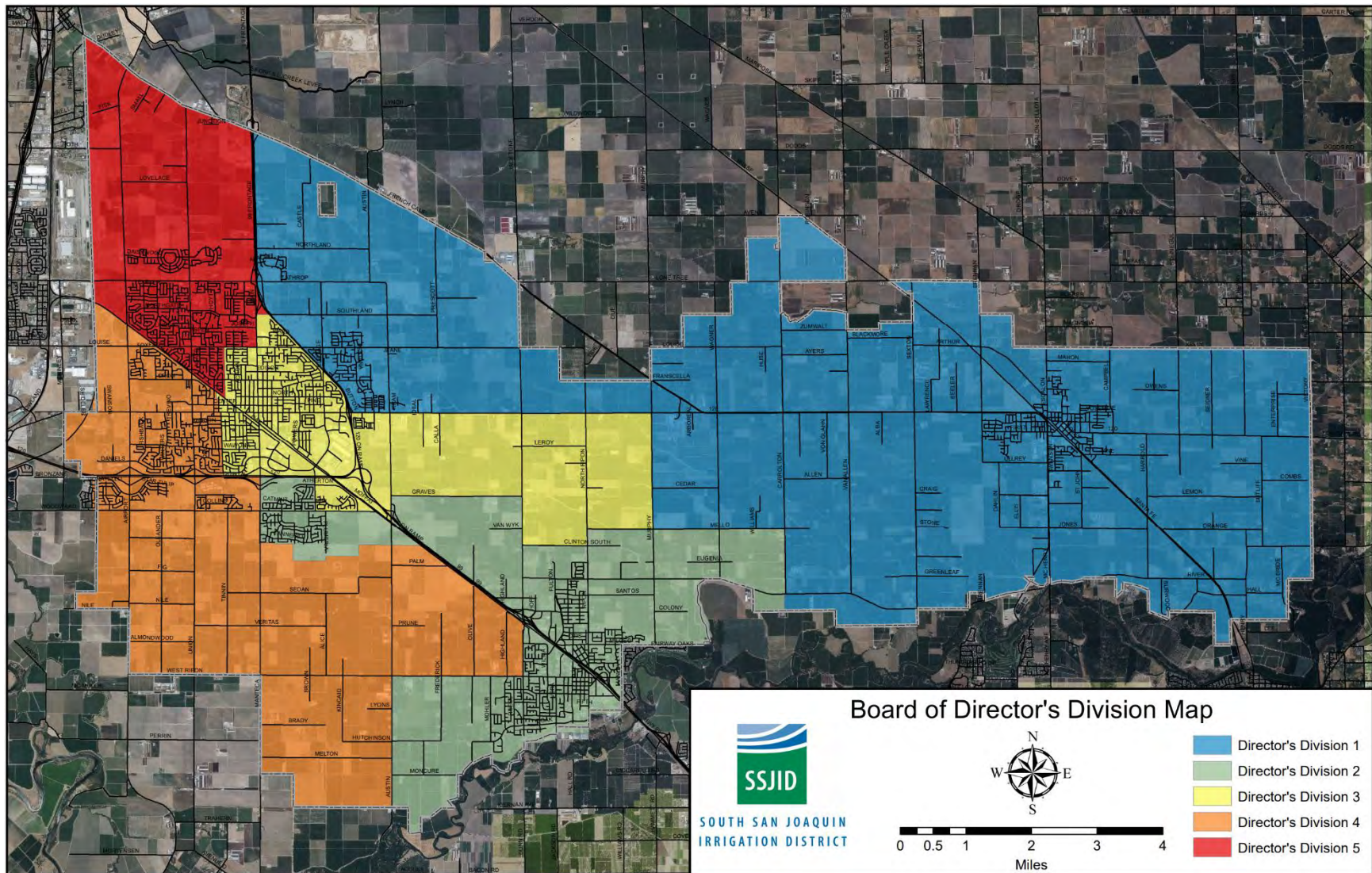

Figure 3-1. SSJID Board of Directors Division Map.

Intentionally Left Blank

The District's General Manager is appointed by the Board of Directors and is the principal administrative officer of the District, as well as the Secretary to the Board of Directors. In general, other management staff report to the General Manager, including the Assistant General Manager, Engineering Department Manager, Irrigation Operations Manager, Water Resources Coordinator, and Water Treatment Plant Manager. Currently, there are more than 100 District employees. An organizational chart of the District is provided in Figure 3-2.

3.3 SIZE AND LOCATION OF SERVICE AREA

The District is located in the northeastern portion of the San Joaquin Valley, approximately 15 miles southeast of Stockton and 11 miles north of Modesto, encompassing the cities of Manteca, Escalon and Ripon (Figure 3-3). All irrigated lands are located north of the Stanislaus River in southeastern San Joaquin County. Woodward Reservoir, approximately 6.5 miles of the Lower Main Supply Canal, and 10.5 miles of the Upper Main Supply Canal are located in Calaveras County. The remaining 2.5 miles of the Joint Supply Canal (to Goodwin Diversion) are located in Tuolumne County. Modesto Irrigation District (MID) lies to the south, OID lies to the east, the South Delta Water Agency lies to the west, and the Central San Joaquin Water Conservation District (CSJWCD) and Stockton East Water District (SEWD) lie to the north.

The District encompasses approximately 72,000 acres, of which approximately 50,000 acres were irrigated in 2024, the last year for which the SSJID water balance was updated.

Intentionally Left Blank

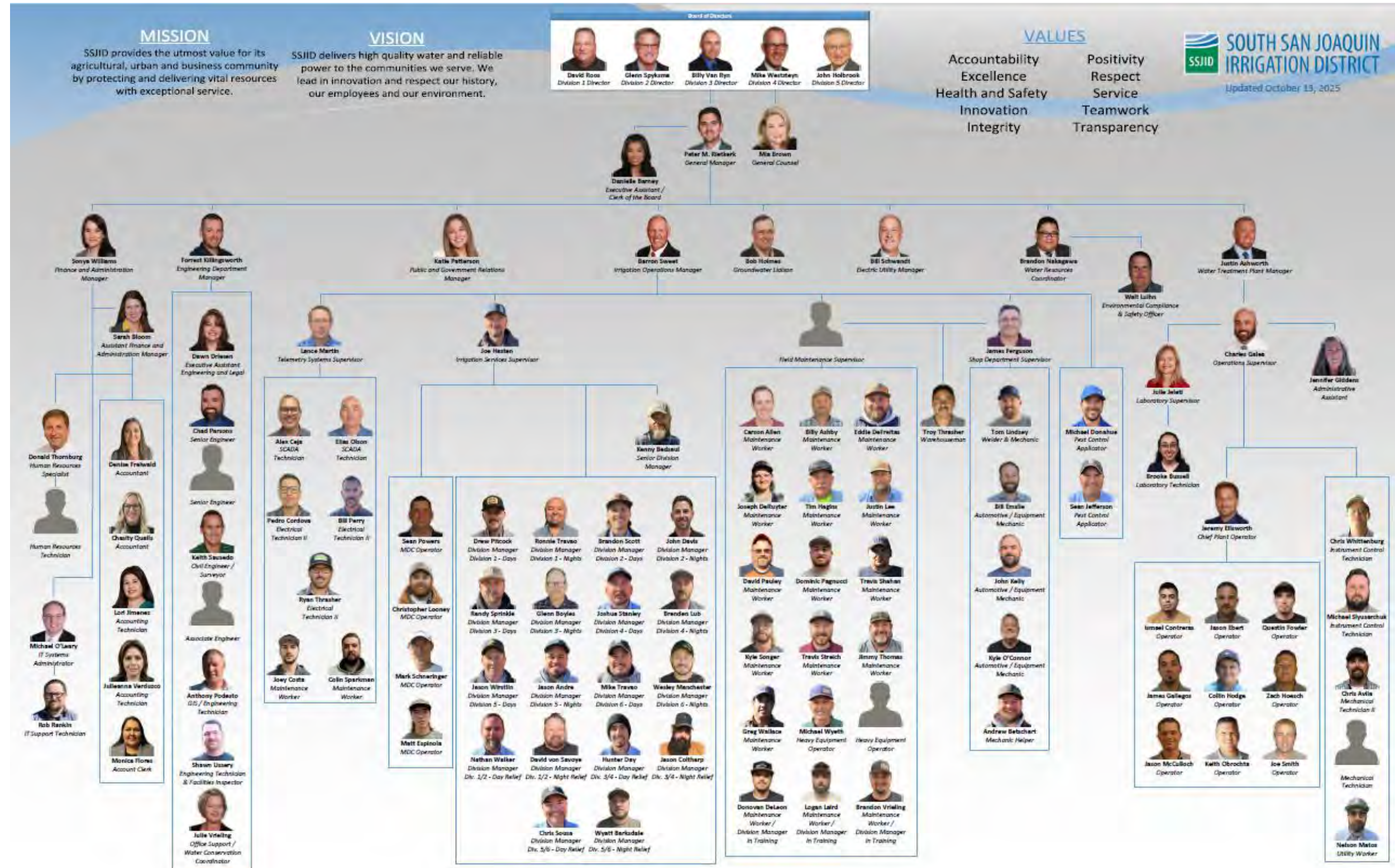

Figure 3-2. SSJID Organizational Chart. Intentionally Left Blank

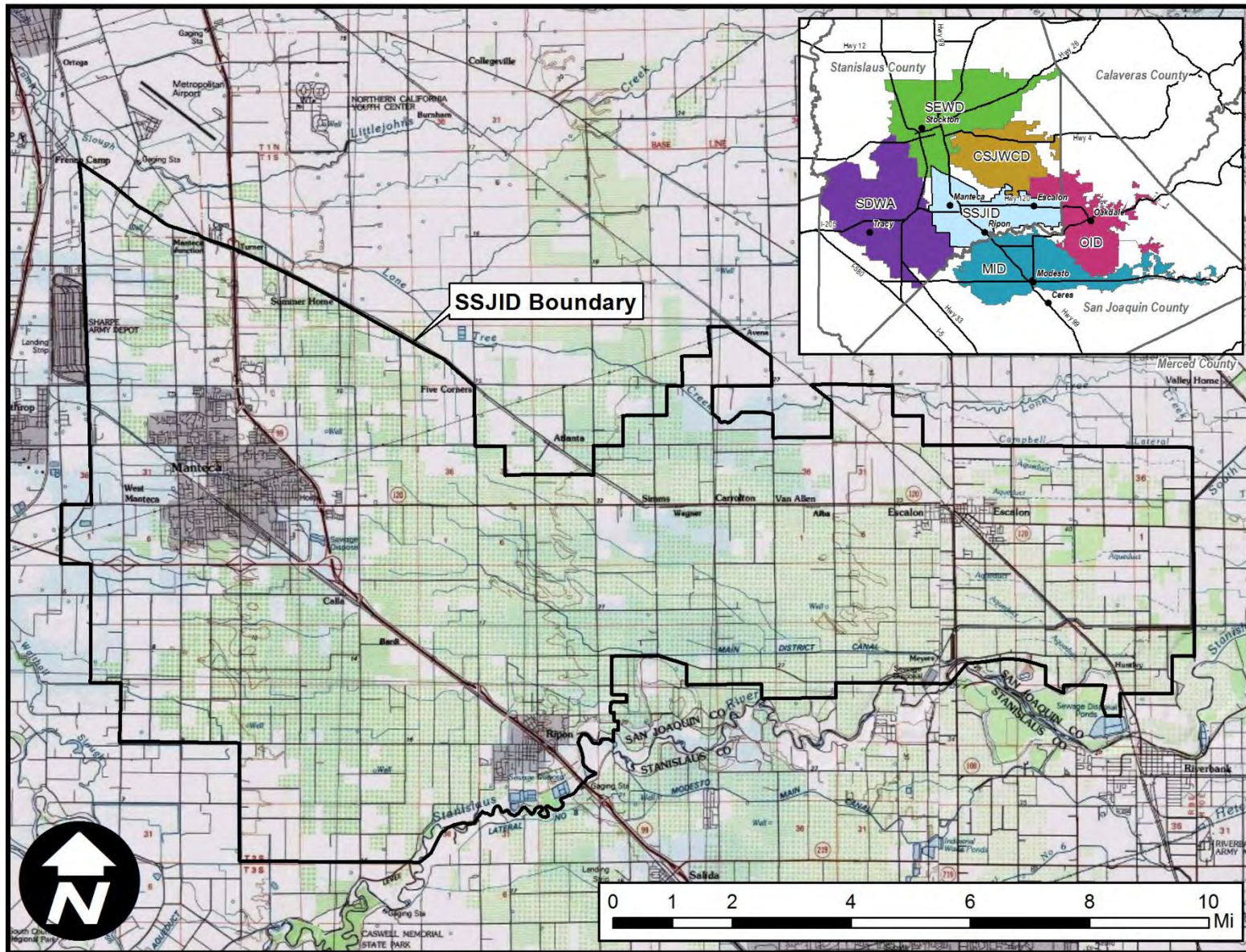

Figure 3-3. SSJID Location Map

Intentionally Left Blank

3.4 SSJID DISTRIBUTION SYSTEM

The SSJID distribution system is described in the subsections below, including the District’s water supply and storage infrastructure, canals and laterals, drainage and spillage infrastructure, groundwater production infrastructure, and water treatment plant.

3.4.1 Water Supply and Storage

SSJID diverts water from the Stanislaus River at Goodwin Dam into the Joint Supply Canal on the north side of the River. The Joint Supply Canal was constructed and is owned and operated by SSJID and OID, with 72 percent of the capacity intended for SSJID and 28 percent intended for OID. OID also has a second diversion channel on the south side of the River. Approximately 3.5 miles downstream of Goodwin Dam, the Joint Supply Canal bifurcates into OID’s North Main Canal and SSJID’s Upper Main Supply Canal (UMSC, Figure 3-4). The UMSC is the sole conveyance serving Woodward Reservoir, all of SSJID’s irrigated area, and the Nick C. DeGroot water treatment plant³. After the split with OID’s North Main Canal, the UMSC continues westward, traveling approximately 10 miles through 11 tunnels and siphons. The largest of these siphons, Hilts’ Sag, was originally a 2,200-foot long wooden flume structure that



Figure 3-4. SSJID Upper Main Supply Canal



Figure 3-5. Woodward Reservoir

crossed OID’s North Canal and bridged a natural gap at a maximum height of 68 feet from the ground. A fire in 1917 and a mud slide in the early 1920s damaged the wooden truss and flume, temporarily delaying service (German, 1942). Shortly thereafter the flume was replaced with a precast concrete structure that stood until 1993, when it was replaced with an underground siphon for earthquake safety concerns.

The UMSC terminates at the Walter J. Woodward Reservoir (Woodward Reservoir, Figure 3-5). The District constructed the

³ The Nick C. DeGroot water treatment plant was dedicated in 2005 and currently serves the cities of Manteca, Tracy, and Lathrop.

36,000 acre-foot Woodward Reservoir in 1916 to provide much needed storage for regulation of diversions and as a safeguard against drought. Today, the reservoir continues to serve these purposes and has been a key feature allowing delivery flexibility and enhancing SSJID’s water conservation capabilities.

3.4.2 Canals and Laterals

Controlled discharges from Woodward Reservoir are channeled in the Lower Main Supply Canal (LMSC), which travels first westward for two miles and then south for an additional two miles before turning southwest and traveling 2.2 miles to the headings of laterals A, B, and B15, and the first of 14 automated check structures (locally referred to as “drop structures”). At that point, the canal enters the irrigation service area and the LMSC becomes the Main Distribution Canal (MDC), travelling south for 2.2 miles and forming the eastern-most boundary of the District. The MDC supplies four more lateral headings before turning west for the final 10 mile stretch and supplying the remaining 17 lateral headings. The MDC is capable of handling flow rates up to 900 cfs.

As of 2024, water is delivered to approximately 1,200 landowners and 2,000 parcels through more than 1,000 delivery points served by approximately 350 miles of laterals off of the main canals. Originally, the entire lateral system consisted of open, unlined ditches. Over time, select laterals and lateral reaches have either been concrete lined or placed in low-head, cast-in-place (CIP) concrete or PVC pipelines. To reduce maintenance requirements, erosion, and seepage losses below Woodward Reservoir, many canals and ditches in the distribution system were lined with concrete in the 1920s through funding from a \$550,000 bond measure passed in 1923. In the 1960s, a low interest loan obtained through the USBR’s P.L. 984 program allowed the replacement of 210 miles of open channel with buried concrete pipe. The majority of the replacement pipe was cast-in-place (CIP). Additionally, related standpipes and water control structures were replaced to enhance operability and to conserve additional water. The pipeline system is considered an “open” system, meaning that it has open control and junction boxes that minimize pressurization of the line.

At present, approximately 312 miles of the District’s laterals are pipelines and 38 miles are open, concrete-lined ditches. The only predominantly unlined open channel is the MDC, totaling 18 miles in length. Although seepage from the unlined MDC generates beneficial groundwater recharge, concerns over embankment erosion prompted the construction of approximately 2,500 feet of concrete lining between drop structures 1 and 3 that was completed before the start of 2013 irrigation season. SSJID crews are targeting between 3,000 and 4,000 linear feet per year of shotcrete lining along the MDC, open laterals, and ditches.

3.4.3 System Modernization Projects

The main canal and lateral distribution system remain upstream-controlled as originally constructed; however, SSJID has implemented a series of system modernization projects to

improve operational flexibility, delivery efficiency, and flow control. Key projects include the Van Groningen Regulating Reservoir (1992), the Northwest Reservoir constructed as part of the System Improvements for Distribution Efficiency (SIDE) Project (2003), full automation of the Main Distribution Canal (MDC), and the East Basin constructed as part of the Irrigation Enhancement Project (Division 9 Project) completed in 2012. These facilities are operated to increase delivery flexibility, reduce operational spillage by minimizing mismatches between diversion and delivery, and provide more consistent flow conditions to downstream laterals, supporting improved on-farm irrigation efficiency.

To support these operations, SSJID has installed automated control structures, including Rubicon FlumeGates® (Figure 3-6) and AquaSystems2000 LOPAC® gates, which maintain target flow rates or upstream water levels. These systems are integrated into the District's SCADA network, enabling real-time monitoring and remote control. Additional automation and flow measurement devices, including SlipMeters® and BladeMeters®, have been installed throughout the system to improve delivery control and measurement accuracy.



Figure 3-6. Flume Gates at Lateral Heading

SSJID has made significant long-term investments in modernization of the MDC. Initial upgrades between 1986 and 1989 included installation of automated control structures and integration with a SCADA system, providing operators with real-time data on flows, water surface elevations, and travel times. Subsequent SCADA upgrades between 1999 and 2003 expanded remote control capabilities and improved flow measurement at lateral headings, resulting in reduced spill and improved delivery service. Continued SCADA and automation upgrades have been implemented to maintain system reliability and incorporate evolving technologies.

The SCADA base station and master control center, constructed in 1996 near the Van Groningen Reservoir (Figure 3-7), serves as the District's central hub for monitoring, control, communications, and operational coordination. In support of improved water balance accounting, SSJID expanded the SCADA system by installing 18 flow measurement devices at drain outflow locations. However, accuracy issues at several sites have limited the reliability of measured outflows.

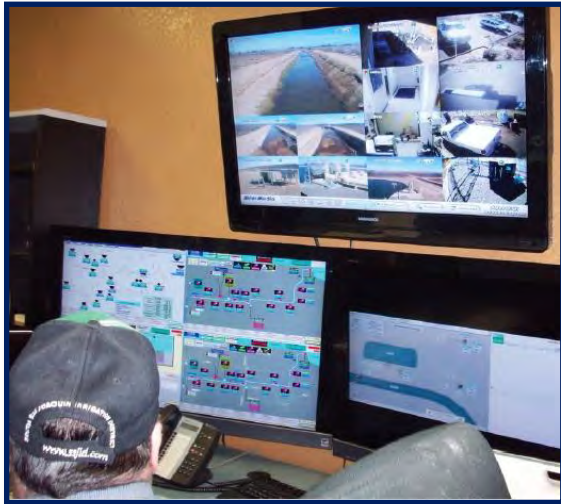

Figure 3-7. SCADA Control Center

In response, the District is undertaking a Drain Outflow Improvement Study to evaluate site conditions and data quality and to develop a structured, prioritized approach for improving measurement reliability. This effort includes development of a comprehensive site inventory, identification of measurement deficiencies and data gaps, prioritization of critical outflow locations, and preparation of a Drain Measurement Improvement Plan. The study will also establish a ranking framework to guide phased implementation of improvements based on their relative importance to water balance accuracy and District operations.

Consistent with the 2022 Water Master Plan, these efforts are part of a broader, phased system modernization strategy supported by a Capital Improvement Plan (CIP) that prioritizes infrastructure upgrades to improve reliability, operational flexibility, and overall system performance. The Water Master Plan emphasizes continued investment in automation, system control, and analytical tools, including water balance evaluation, to support long-term water management and operational decision-making.

SSJID has also implemented improvements to enhance monitoring and communication, including development of a licensed communication network and installation of microwave towers to support SCADA operations.

Additional measurement and automation upgrades have been completed at key locations, including Woodward Reservoir and major system control points.

With improved control of system inflows, SSJID has increasingly focused on modernization of the lateral distribution system. The Irrigation Enhancement Project (Division 9 Project) represents a significant advancement, providing a pressurized pipeline network serving approximately 3,800 acres and 77 customers. The system includes a regulating reservoir (Sam Bologna Reservoir) (Figure 3-8), pump station with variable frequency drives, pipeline distribution system, automated flow control, and real-time monitoring. This project has improved irrigation



Figure 3-8. Irrigation Enhancement Project Sam Bologna Reservoir

efficiency, reduced reliance on groundwater, and enhanced groundwater recharge within the District.

In addition, SSJID has implemented operational and structural improvements to better accommodate increasing use of pressurized irrigation systems. These include installation of float valves, automated gate controls with downstream water level sensors, and modifications to pipeline control structures to improve flow regulation and reduce stress on aging infrastructure. These enhancements provide greater delivery precision, operational flexibility, and system longevity. Locations of downstream water level sensors are shown in Figure 3-9.

SSJID continues to evaluate and implement system modernization projects consistent with the Water Master Plan framework, with a focus on improving measurement accuracy, delivery efficiency, and overall water management capabilities.

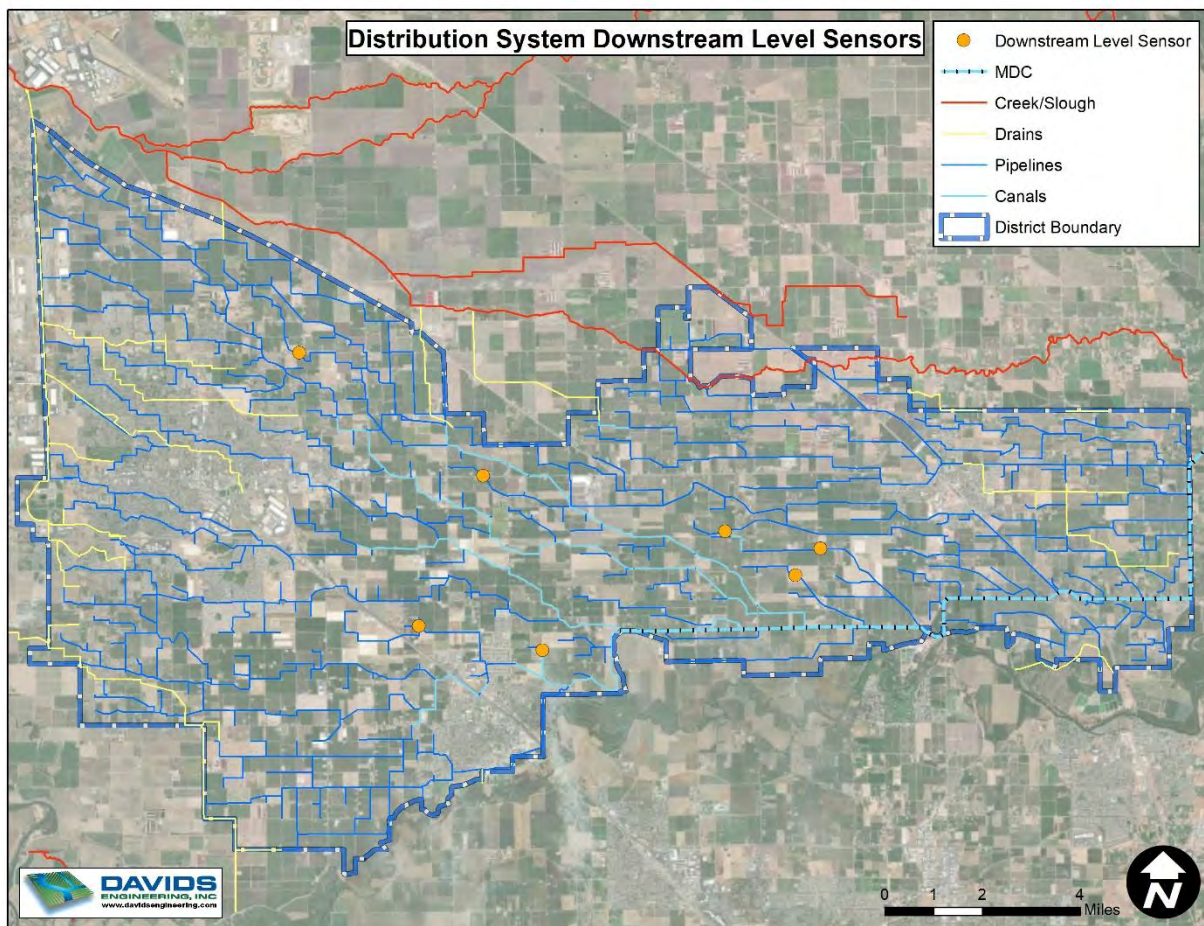

Figure 3-9. SSJID Downstream Level Sensor Locations.

3.4.4 Delivery Structures

Originally, the distribution system was designed to provide irrigation water to growers using graded border, graded furrow, and level basin surface irrigation methods. As such, delivery structures to individual fields commonly consist of large valves spaced evenly on a pipeline running along the head of the field (Figure 3-10). In many cases, the valves are installed directly in the SSJID lateral pipeline. A downstream control structure or “check box” allows the Division Manager to deliver all or a portion of the flow out of the upstream irrigation valves.



Figure 3-10. Surface Irrigation Valves

Where field boundaries are not aligned with the lateral pipeline, an orifice gate within a check box is typically used to deliver water to a privately owned pipeline serving the field. In this configuration, surface irrigators apply water directly through field valves, while pump irrigators utilize concrete sump boxes to provide limited operational storage and buffer mismatches between delivery flow rates and pump capacity.

While the system was originally designed for surface irrigation, it has been successfully adapted to support a growing number of pump and pressurized irrigation deliveries. However, these adaptations introduce operational constraints and have required ongoing refinement of delivery practices, flow control, and measurement approaches. Consistent with the District’s broader system modernization efforts identified in the 2022 Water Master Plan, SSJID continues to evolve its delivery structures and operational strategies to improve flexibility, accommodate changing on-farm irrigation methods, and enhance overall delivery efficiency and water management. Measurement of deliveries is described in detail in Section 3.8

3.4.5 Drainage and Spillage

The District maintains 60 miles of dedicated drainage ways of which 23 miles are buried pipelines, and the remainder are unlined or lined open ditches. There is only one main drain entering the District, Lone Tree Creek. Drainage generally flows westerly to the San Joaquin River or northerly to Lone Tree Creek. Any southerly drainage flows into the Stanislaus River. The French Camp Outlet Canal (FCOC) runs south to north along the District’s western boundary and is the main collector of drainage flows (Figure 3-11).

SSJID actively manages drainage flows as part of its overall water delivery system. Where feasible, drain water is recaptured and redirected into the distribution system to augment available supply and improve operational flexibility. Two emergency spill locations exist on the



Figure 3-11. French Camp Outlet Canal

Main Distribution Canal (MDC) near Ripon and Escalon that discharge to the Stanislaus River if necessary. Historically, these spills were used as operational balancing tools, including when tailwater from upstream systems entered the District. However, the need for such spills has been significantly reduced due to the construction of regulating reservoirs, increased system automation, and improved operational control. The FCOC, in conjunction with the Escalon Spillway, is also used to support releases for maintenance of instream flows in coordination with the U.S. Bureau of Reclamation.

In addition to agricultural drainage, SSJID’s drainage system provides conveyance for urban stormwater through agreements with the Cities of Manteca and Escalon. Stormwater is conveyed via gravity discharge into open drains and through pump systems that discharge into District pipelines and canals. As urban development has expanded, some District conveyance facilities have been repurposed, decommissioned, or transferred for municipal stormwater use. For example, the Tb Lateral in the western portion of Manteca is now used primarily by the City for stormwater collection.

Accurate measurement of drainage flows is critical to quantifying these operations and supporting the District’s water balance. As described in Section 3.4.3, SSJID completed a Drain Outflow Improvement Study to evaluate existing measurement conditions and develop a prioritized plan to improve the accuracy and reliability of drain flow data, particularly at key boundary outflow locations.

Consistent with the 2022 Water Master Plan, the District’s management of drainage facilities reflects an integrated approach to water resources, where conveyance, reuse, operational flexibility, and infrastructure adaptation are coordinated to support efficient water delivery, system reliability, and long-term water management objectives.

3.4.6 Groundwater Production

SSJID owns and operates groundwater production wells to support both groundwater level management and supplemental water supply. These wells are predominantly located in the western portion of the District, where groundwater levels are relatively shallow. Operation of these wells helps control the high groundwater table while also providing supplemental supply during periods of reduced surface water availability.

In recent years, the District has rehabilitated existing wells operating at suboptimal efficiency and constructed additional wells to address localized capacity constraints within the distribution system. Siting and development of these facilities have been informed by system-wide modernization planning efforts to ensure alignment with long-term operational needs. These wells are an important component of the District’s conjunctive use strategy, supporting groundwater management, operational flexibility, and overall water supply reliability.

3.4.7 Water Treatment Plant

In addition to providing water for irrigation, SSJID supplies treated surface water to the Cities of Manteca, Lathrop, and Tracy for municipal use. Phase I of the Nick C. DeGroot Water Treatment Plant (WTP) was completed in 2005 just below Woodward Reservoir Dam (Figure 3-12), with water supplied from Woodward Reservoir. Phase II of the project includes planned expansion of service to Escalon, while the City of Ripon currently receives untreated surface water and is evaluating conversion to treated water service.



Figure 3-12. Nick C. DeGroot Water Treatment Plant and Robert O. Schulz Solar Farm

The WTP is part of the larger South County Water Supply Project, which includes a dedicated pipeline distribution system. Municipal deliveries are measured using electromagnetic flow meters to ensure accurate accounting. In 2024, the WTP delivered nearly 24,000 af and operated at or near capacity during peak demand months.

The District’s ability to provide municipal surface water supplies is supported by long-term system improvements and water conservation achieved through infrastructure modernization. These improvements have allowed SSJID to meet municipal demands

without adversely affecting agricultural deliveries. Consistent with District agreements, municipal deliveries are subject to the same proportional allocation reductions as agricultural users during drought conditions.

SSJID completed the Robert O. Schulz Solar Farm at the WTP in 2009. The 1.4 MW project, including nearly 7,000 photovoltaic panels installed on 14 acres of land offsets the power used to operate the WTP delivering significant savings to WTP customers..

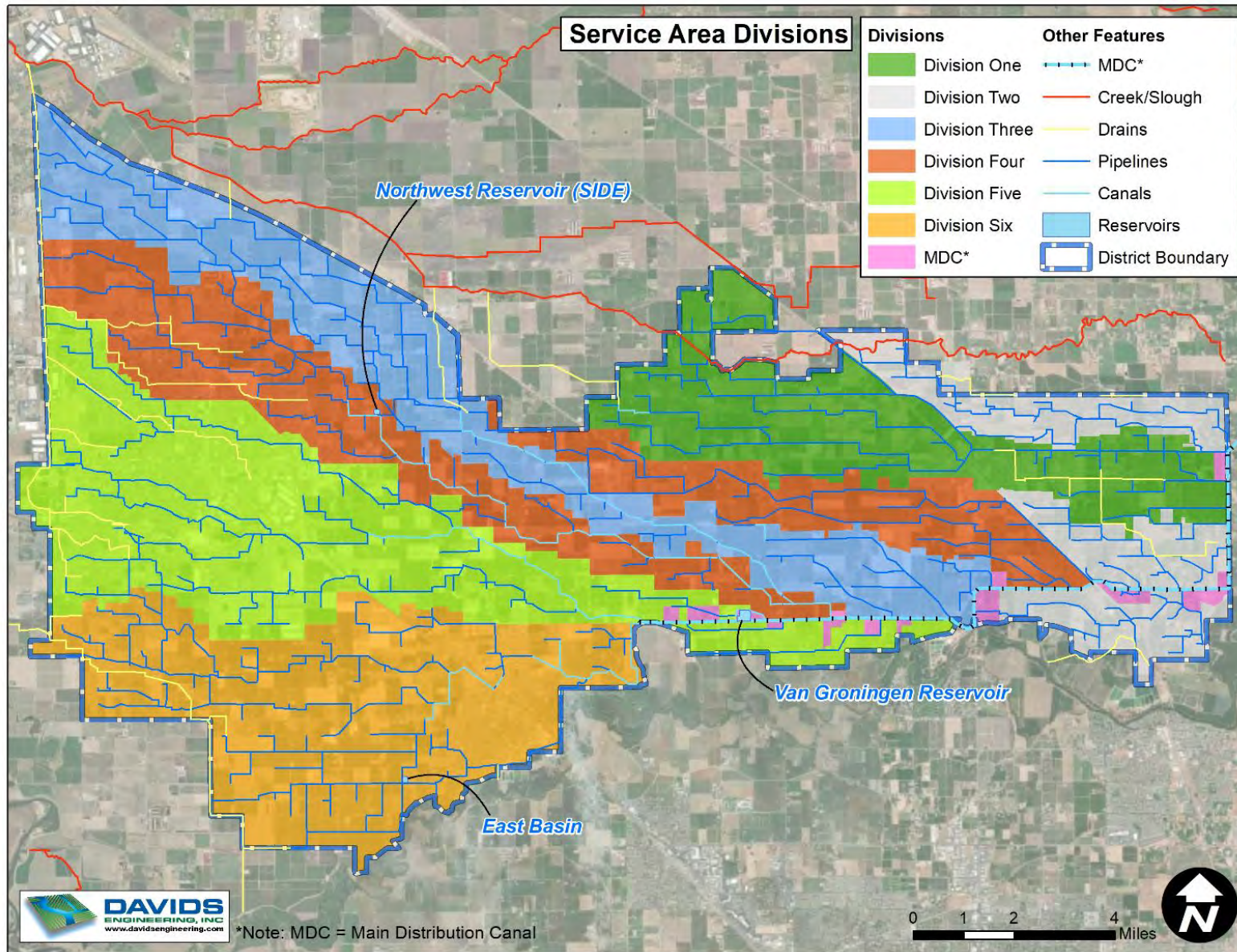

Figure 3-13. SSJID Service Area Divisions

Intentionally Left Blank

3.4.8 Operational Divisions and Water Deliveries

The District is currently divided into six operational divisions. A map of the District’s Service Area Divisions is provided in Figure 3-13 on the previous page. Within divisions, actual field operations are executed by Division Managers (DMs) (Figure 3-14). SSJID provides 24-hour a day 7-day a week service during the irrigation season.

Based on the District’s TruePoint electronic delivery tracking data for 2024 (described in greater detail below), division size ranges between approximately 4,700 acres and 8,200 acres and averages approximately 6,500 acres. The number of parcels per division ranges between 247 and 376 and averages 320. The average parcel size in each division ranges between approximately 16 and 23 acres, and averages about 20 acres. To the extent possible, divisions are organized so that DMs have control of their water from the main lateral heading to the tail of their respective laterals. There are cases, however, where water is passed through one division to the next, rather than being delivered directly from the Main Distribution Canal.



Figure 3-14. SSJID Division Manager Measuring Flow

SSJID has historically delivered water on a rotational basis. The distribution system and operating procedures are designed around a 10-day average rotation⁴. The season begins typically in mid-March to early April and continues until early to mid-October. The rotation frequency may vary slightly by division based on crop types, irrigation methods or user requests. DMs may operate two separate rotation frequencies to cater to specific needs.

Historically, DMs have used “rotation sheets” to organize water deliveries. One rotation sheet is prepared for each lateral (or rotational unit), with the customers listed on the sheet in the order in which they will receive water. This order is referred to as the delivery “run.” Important information about each customer is also provided on the sheet, including the customer’s name, address, phone number, customer name and phone number, crop type, assessor’s parcel number (APN), irrigated acreage, number of hours to receive irrigation water, and delivery flow rate.

As part of the modernization process, SSJID transitioned to TruePoint data collection software program in 2010 to digitally record delivery flow rate and start and stop times (duration) on laptop computers mounted in the DMs pickup trucks. The data is uploaded to a central computer

⁴ Rotations of 14 or 20 days are provided by some DMs in some divisions as warranted based on customer needs.

at the main office once per day. The TruePoint water ordering and tracking system is discussed further in Section 3.8.

Each division has a dedicated cellular phone used to notify customers of delivery timing and coordination of water transfers between users. The phones are shared between day and night shift Division Managers (DMs), providing customers with a single point of contact available 24 hours a day.

Customers typically call DMs to request schedule changes or to report unusual conditions such as delivery interruption. Prior to the start of a rotation, the DM calls each customer in the rotation to see if they would like water. Users can confirm their order or pass until the next rotation. The rotation schedule is adjusted accordingly. Permanent crops are often irrigated throughout the irrigation season while irrigation of field crops, alfalfa, etc. may begin later based on crop-specific water needs.

Each DM is responsible for determining how much water their division will need on at least a daily basis, and for requesting that amount from the control room operators. Typically the required flow rate is predetermined due to the nature of a rotational delivery system, or is limited by the lateral capacity. The control room schedules two times during the day that flow rate changes can be made at the lateral headings off of the MDC and prefers that the DMs make their requests accordingly; however, automated gates and remote control allow changes to be made more frequently during the height of the season based on changes in customer demand. Communication between DMs and with headquarters is facilitated by a two-way radio system and cell phones.

The control room operators total the division requests, calculate the required change from the current flow rate, and initiate changes in diversions at Woodward Reservoir. The releases from Woodward Reservoir and many of the lateral headings off the MDC are remotely controlled through the District's SCADA system by staff in the control room. Based on the DMs' requests, and accounting for travel time from the dam, the control room will remotely adjust the lateral heading to deliver the requested flow rate at the requested time. Gates not located on the MDC are typically adjusted by the DMs. The DMs may also cooperatively transfer water between divisions to manage their rotations, if water is available. For example, if one division is cutting 10 cubic feet per second (cfs) and the adjoining division is adding 10 cfs, the water can be transferred between the two, thereby avoiding routing two flow changes along the main canal.

At the 10-day rotation interval, the DM will begin a "run" either at the top end or bottom end of the division and deliver a "head" of water from one delivery point to the next, based on an established schedule, the capacity of the lateral, and the quantity ordered from the control room.

3.4.9 Delivery Flexibility

The standard flood “head” delivered to irrigators is 25 cfs. Each delivery point receives the water for a predetermined duration that is established, in part, by the acreage and crop type served. There is some flexibility in the delivery duration to accommodate changes in the required delivery duration over the course of the irrigation season. SSJID’s laterals are typically sized to convey one, two, or three heads for rotational delivery to growers. Along laterals sized to convey multiple heads, DMs have the ability to deliver to multiple delivery points at the same time and to allow alternative rotation schedules along the length of the lateral and/or its sub-branches. When more than one owner is served by a delivery location, the full head is either split between customers or passed (rotated) from parcel to parcel by customers, with the delivery duration varying according to parcel size and other factors.

Customers’ needs have evolved over time, with irrigation of specialty crops and increasing use of high-frequency, long duration, low flow rate irrigation systems, such as microirrigation and sprinklers. Based on 2024 TruePoint data, approximately 69% of the delivery events in SSJID had a reported flow rate of 4 cfs or less. These deliveries were responsible for nearly half of the volume delivered that year.

To better meet these evolving needs, SSJID’s DMs consider and accommodate, to the best of their ability, delivery requests from growers who desire to irrigate outside of their scheduled rotation. Ultimately, requests are considered and approved at the discretion of the DM and vary from division to division based on operational constraints. Divisions with high concentrations of pressurized irrigation systems are generally able to successfully provide arranged-demand delivery.

Delivery start times are arranged, and shutoff times are scheduled at the same time that the water order is placed. Shutoff times may be modified by the irrigator in coordination with the DM, subject to the capacity and operational constraints of the distribution system. Division Managers may also schedule two separate rotations within the same lateral pipeline: one for flood irrigators (25 cfs) and one for micro irrigators (typically 2 to 6 cfs, often referred to as a “pump head”). Often times this is not possible, and the DM will instead deliver a pump head to micro- or sprinkler-irrigators and deliver the remaining partial head to a user who may flood irrigate. This requires additional coordination and effort by the DM.

As the amount of pressurized irrigation has increased, it has become increasingly difficult to provide the desired flexibility to sprinkler- and micro-irrigators while maintaining existing levels of service to surface irrigators without system modernization. In response, SSJID has and continues to modernize its distribution system and update operational procedures to provide flexibility and equity to its customers. Conjunctive use of water through installation of privately-owned groundwater wells and operation of District-owned wells is common in SSJID. The advantages of privately-owned wells to growers include complete flexibility in providing water

for frost protection, chemigation, and fertigation, and to better align irrigations with crop water demands, field activities, and harvest.

Woodward Reservoir is key to SSJID’s ability to offer flexible service. The Reservoir is operated to maintain a specific downstream flow rate. SSJID operators coordinate with the Tri-Dam project personnel to adjust Goodwin Dam diversions as needed to maintain target storage amounts. If downstream demand increases, requiring an increase in releases at the Reservoir, the Superintendent checks whether the change can be made within the operational limits described below. Unless constrained by operational limits, the Superintendent requests the operator at the Tri-Dam Project to divert the additional water.

The reservoir is located nearly 15 miles closer to the irrigated lands than the river diversion, serving as a re-regulation point that can be called upon for flexible changes in service that are not possible at the river diversion. It provides buffer storage to absorb excess diversions and provides localized supply for increases in MDC flows, improving service levels, minimizing spillage, and minimizing operational changes at Goodwin Dam.

Per the District’s Rules and Regulations, growers are required to notify the District of their planned water needs (crop(s), acreage, etc.) between January 1st and June 1st of each year they plan to irrigate so that the District can develop a crop report and water usage records can be updated or developed.

Current daily use is determined from flow measurement sensors or rated gates at each of the lateral headings, and is relayed back to the Control Room using telemetry. All this information is tracked using the SCADA system and reports generated by the Control Room. Monitoring devices installed along the MDC, within the Divisions, and at spill sites allow the Control Room to regulate daily water use and provide DMs with helpful management information.

3.5 TERRAIN AND SOILS

The topography and soils within the District are typical of the San Joaquin Valley floor. The land surface is gently sloped westerly with elevations that vary from 150 feet in the east near Escalon to about 50 feet near Manteca, with a relatively constant land slope. Surface water drainage generally flows southwesterly towards the San Joaquin River.

Historical flooding of the region’s major rivers left layers of sediments and silts in the San Joaquin Valley floor, creating a unique soil profile that is well suited to irrigated agriculture, particularly for deep rooted tree crops such as walnuts and almonds. Soils in SSJID are typically deep and well drained with soil textures ranging from fine silts and sands in lower areas to medium textures in the low alluvial fan and terrace areas, with deposits of coarse-grained sands and gravels. SSJID does not contain expansive soils, and the erosion hazard rating is slight, indicating that erosion is unlikely under ordinary climatic conditions (NRCS, 2007).

3.6 CLIMATE

The climate statistics presented in this section are based on the California Irrigation Management Information System (CIMIS) Station at Manteca (#70), established in 1987. This station was also used for the water balance analysis presented in Section 5.

SSJID has a climate typical of the San Joaquin Valley. Winters are mild with moderate precipitation, while summers are generally warm and dry. Average daily maximum temperatures range from a low of about 57.9°F in December and January to a high of 94°F in July (Table 3-1). Mean daily minimum temperatures range from a low of 37.6°F in December to a high of about 58.6°F in July. Average annual reference evapotranspiration (ET_o) is approximately 53.3 inches, ranging from a low of approximately one inch in December and January to a high of approximately eight inches in July. Approximately three quarters of the annual ET_o occurs in the six-month period from April through September.

Table 3-1. Mean Weather Parameters at Manteca CIMIS Station (1994-2024)

Month	Total ET _o (in)	Total Precip. (in)	Daily Temperature (°F)			Relative Humidity (%)			Wind Speed (mi/hr)
			Avg.	Min.	Max.	Avg.	Min.	Max.	
January	1.2	2.7	47.7	39.1	58.5	86.3%	65.1%	98.4%	4.0
February	2.0	1.8	50.1	38.1	63.6	72.3%	46.2%	96.0%	4.3
March	3.5	1.7	53.9	42.0	66.9	72.7%	46.6%	96.2%	4.4
April	5.0	1.0	59.6	46.1	74.2	64.7%	39.9%	94.7%	4.9
May	6.7	0.5	65.3	50.5	80.3	58.8%	37.1%	90.7%	5.3
June	7.8	0.1	72.3	56.0	88.7	52.5%	32.2%	86.4%	5.1
July	8.2	0.0	76.1	58.6	94.2	50.4%	29.3%	86.7%	4.6
August	7.2	0.1	74.7	58.5	92.4	55.8%	32.9%	90.6%	4.3
September	5.3	0.1	70.5	54.9	87.8	58.1%	33.0%	91.9%	3.9
October	3.6	0.7	62.3	47.5	79.7	62.0%	34.0%	93.0%	3.3
November	1.7	1.2	51.6	39.2	66.5	75.7%	47.9%	96.7%	3.0
December	1.1	2.5	46.8	37.6	57.9	82.5%	59.0%	96.8%	3.5
Annual	53.3	12.5	60.9	47.3	75.9	66.0%	41.9%	93.2%	4.2

Average annual precipitation is approximately 12.5 inches, with 10.0 inches, or approximately 80 percent occurring in the five-month period from November through March.

Even during the peak summer period, the average maximum relative humidity reaches over 80 percent, which is indicative of an irrigated area, and exceeds 95 percent between November and March. Minimum relative humidity ranges between approximately 32 percent during June through September, and approximately 50 percent during the wet winter months. Average wind speed is lowest in November (3.0 miles per hour) and highest in May and June (5.3 miles per

hour). There are no significant microclimates within the district that affect water management or operations.

3.7 OPERATING RULES AND REGULATIONS

The District maintains “Rules and Regulations for Governing the Distribution of Water in the South San Joaquin Irrigation District” (Rules and Regulations) for control of system facilities, employee conduct, apportionment of water, rotation of water, irrigation time limits, continuous use of water, deliveries, control, waste of water, access to land, breaks, use of rights-of-way, unlawful acts, and enforcement and modification of rules. The intention of the rules and regulations is summarized as follows:

“It is the desire and intention to carry on the business of the District in a businesslike and economical manner and to distribute the water equitably, and, as near as may be satisfactory to all water users. No two individuals have exactly the same requirements and while these individual requirements will be met as far as possible, yet there must be general rules and general practices to secure the greatest good to the greatest number.”
(SSJID, 1919)

The District plans to review and revise the Rules and Regulations as necessary. The Rules and Regulations prescribe conditions that ensure distribution of irrigation water to users in an orderly, efficient and equitable manner. The existing Rules and Regulations are available to water users and the public in pamphlet form, and are attached to this report for convenient reference (Appendix B).

3.8 WATER DELIVERY MEASUREMENT AND CALCULATION

In recent years, SSJID has made substantial efforts to improve flow measurement to support efficient management of the District’s water resources and planning. The general approach to improving water measurement within SSJID has been to focus initial efforts on improving the measurement of inflows and outflows at the District boundaries (where needed), and then to improve internal flow measurements, prioritizing upstream flows. This approach has enabled development of a District-wide water balance, and increasingly supports future development of water balances for each of the District’s divisions. The following sections describe boundary and system flow measurements, followed by delivery flow measurements.

3.8.1 Boundary and System Flow Measurement

Water diverted from the Stanislaus River into the Joint Main Canal is measured by stream gage stations operated and maintained by the Tri-Dam Authority to U.S. Geological Survey (USGS) standards.

Releases to the Main Distribution Canal (MDC) below Woodward Reservoir are controlled through SCADA and measured using an acoustic Doppler device installed in a rated section below Woodward Dam (USGS Station 11300700), providing accurate measurement of distribution system inflows (Figure 3-15). SSJID staff perform periodic calibration and verification of flow measurement devices to maintain accuracy. A flow measurement station at Valley Home Drop provides an additional point of measurement downstream of the Woodward takeout.



*Figure 3-15. Woodward Release
Gaging Station*

Deliveries from the MDC to laterals have historically been measured using rated orifice gates, weirs, flumes, and rated canal sections. In recent years, SSJID has upgraded these facilities with SonTek Pipe IQ acoustic Doppler devices installed at lateral headings, allowing for improved accuracy and real-time monitoring through the SCADA system. In addition, Rubicon Water FlumeGates® and AquaSystems2000 LOPAC® gates have been installed at selected locations to provide both automated flow control and measurement, supporting smoother routing of flow changes and improved operational efficiency.

Additional measurement and control improvements have been implemented at key system locations, including installation of Rubicon SlipMeters® to enhance flow measurement and operational flexibility at points where flows are divided between laterals and at regulating reservoirs.

Within divisions, DMs perform localized flow measurements using a combination of traditional and advanced methods, including weir sticks, measuring tapes, staff gauges, and acoustic Doppler meters. Select locations are equipped with SonTek and ISCO acoustic Doppler meters that provide local readouts and transmit data through the SCADA system for remote monitoring. Water surface elevation at rated structures is measured using pressure transducers, ultrasonic sensors, and stilling wells.

System spillage and on-farm tailwater are collected through a network of District and private drains and discharged at multiple boundary locations. These flows may be reused by downstream irrigators or contribute to flows in the Stanislaus and San Joaquin Rivers.

SSJID has made significant progress in improving boundary flow measurement. A majority of District outflows are now measured at key locations, including operational spill sites and drainage outflows. However, variability in site conditions and legacy infrastructure has resulted in ongoing challenges with measurement accuracy at certain locations. In response, the District completed a Drain Outflow Improvement Study (see Section 3.4.3) to evaluate existing

measurement conditions, identify deficiencies, and develop a prioritized plan for improving the accuracy and reliability of boundary flow measurements.

Consistent with the 2022 Water Master Plan, SSJID continues to invest in modernization of flow measurement infrastructure, expanded SCADA integration, and improved data collection to support more accurate water balance accounting, operational decision-making, and long-term water management.

3.8.2 Water Delivery Measurement and Calculation

SSJID utilizes centralized data management and reporting systems to track water deliveries, support volumetric billing, and provide accurate accounting of water use throughout the District. Delivery information, including flow rates, duration, and associated parcel and crop data, is recorded and maintained through the District's TruePoint system, which serves as the primary platform for water ordering, tracking, and reporting. These tools enhance transparency, improve operational coordination, and support compliance with regulatory requirements. Integration of delivery data with field measurements and SCADA-based system monitoring provides a comprehensive framework for managing water deliveries and supporting informed decision-making.

3.8.1.1 Ongoing Efforts for Compliance with SBx7-7

SSJID has made significant progress in improving the accuracy of delivery measurements and continues to implement a structured program to meet the requirements of SB x7-7 and §597 of Title 23 of the California Code of Regulations (23 CCR §597). Key elements of this program include installation of magnetic flow meters at delivery points, use of acoustic Doppler meters (ADMs) to support operational measurement and flow balancing, and implementation of system-wide improvements identified through the District's Water Master Plan.

The District has prioritized measurement improvements that align with long-term infrastructure modernization efforts to ensure investments remain compatible with future system upgrades. These efforts are supported through the District's capital improvement planning process and are coordinated with broader system modernization initiatives identified in the Water Master Plan.

Documentation of the District's current agricultural water measurement compliance efforts is provided in Appendix A. SSJID will continue to refine its measurement program and update its corrective action plan as needed to achieve compliance with 23 CCR §597 accuracy standards.

3.8.1.2 Irrigation Enhancement Project and On-Farm Water Conservation Program

SSJID has implemented targeted projects to improve delivery measurement accuracy, most notably through the Irrigation Enhancement Project (Division 9 Project). In this area, all deliveries are measured using magnetic flow meters with a manufacturer-certified accuracy of ± 1 percent. These meters are installed at approximately 77 turnouts serving about 3,800 acres and

are integrated with the SCADA system, providing real-time flow data to both District staff and growers (Figure 3-16).

The District has also supported on-farm measurement improvements through its On-Farm Water Conservation Program, which facilitated installation of magnetic flow meters on pump deliveries and pressurized irrigation systems. Through this program and related efforts, hundreds of highly accurate magnetic flow meters have been installed throughout the District, supporting volumetric measurement, improved water management, and regulatory compliance.



Figure 3-16. Magnetic Flow Meter

3.8.1.3 Delivery Measurement Program (CCR 23 §597)

In fulfillment of the delivery measurement accuracy requirements of §597 of Title 23 of the California Code of Regulations (CCR), SSJID has installed magnetic flow meters at selected turnouts and pump deliveries throughout the District. As of 2024, more than 310 magnetic flow meters have been installed in SSJID, including 77 meters in the Irrigation Enhancement Project area and more than 233 meters installed elsewhere in the system. Information about the



Figure 3-17. Orchard Valve Installed on SSJID Pipeline

District’s delivery measurement program efforts are described in Appendix A.

Outside of the Irrigation Enhancement Project area, farm deliveries without magnetic meters are currently measured by rated gates or, in some cases, by determining the difference in flow between stand structures in the lateral upstream and downstream of the farm turnout.

Direct measurement of deliveries to some individual fields is not technically feasible because multiple irrigation valves serving the field have been installed directly in the SSJID lateral pipeline (Figure 3-17). This tends to occur where the pipeline runs along the head of the field. The only technically feasible solution in these cases is to measure delivery volumes using a volume differential method. DMs read in-line flow meters where present and use manufacturer-provided pump capacities for estimating pump delivery flow rates where flow meters are not present.

As noted in the previous section, SSJID has installed new, more accurate SonTek Pipe IQs at lateral headings, and has installed or plans to install additional flow measurement devices at other locations along laterals to improve delivery measurement throughout the District.

3.8.1.4 Other Delivery Measurement

SSJID has implemented additional measurement verification and pilot programs to support accuracy and responsiveness. These include the use of portable current meters to verify delivery rates and pilot projects evaluating the use of acoustic Doppler meters within lateral systems to improve measurement resolution at the farm level. These efforts have informed broader implementation of measurement technologies across the District and continue to support refinement of delivery measurement practices.

3.8.1.5 Delivery Data Management Software and Reporting Tools

SSJID utilizes the TruePoint data management system to track water deliveries, support volumetric billing, and provide reporting of water use. Delivery data recorded by Division Managers includes start and stop times, flow rates, and key attributes such as parcel information, crop type, acreage, lateral, and irrigation method. The system calculates delivery duration, volume, and applied water depth based on these inputs (Figure 3-18).

SSJID provides online account access for growers, allowing them to view water usage and billing information. Additional tools, including an on-farm meter data portal, provide access to real-time and historical flow data for participating users. Growers can view delivery information in multiple formats, including calendar-based summaries of irrigation events (Figure 3-19).

These systems enhance transparency, support improved on-farm water management, and strengthen the District's overall data management capabilities.

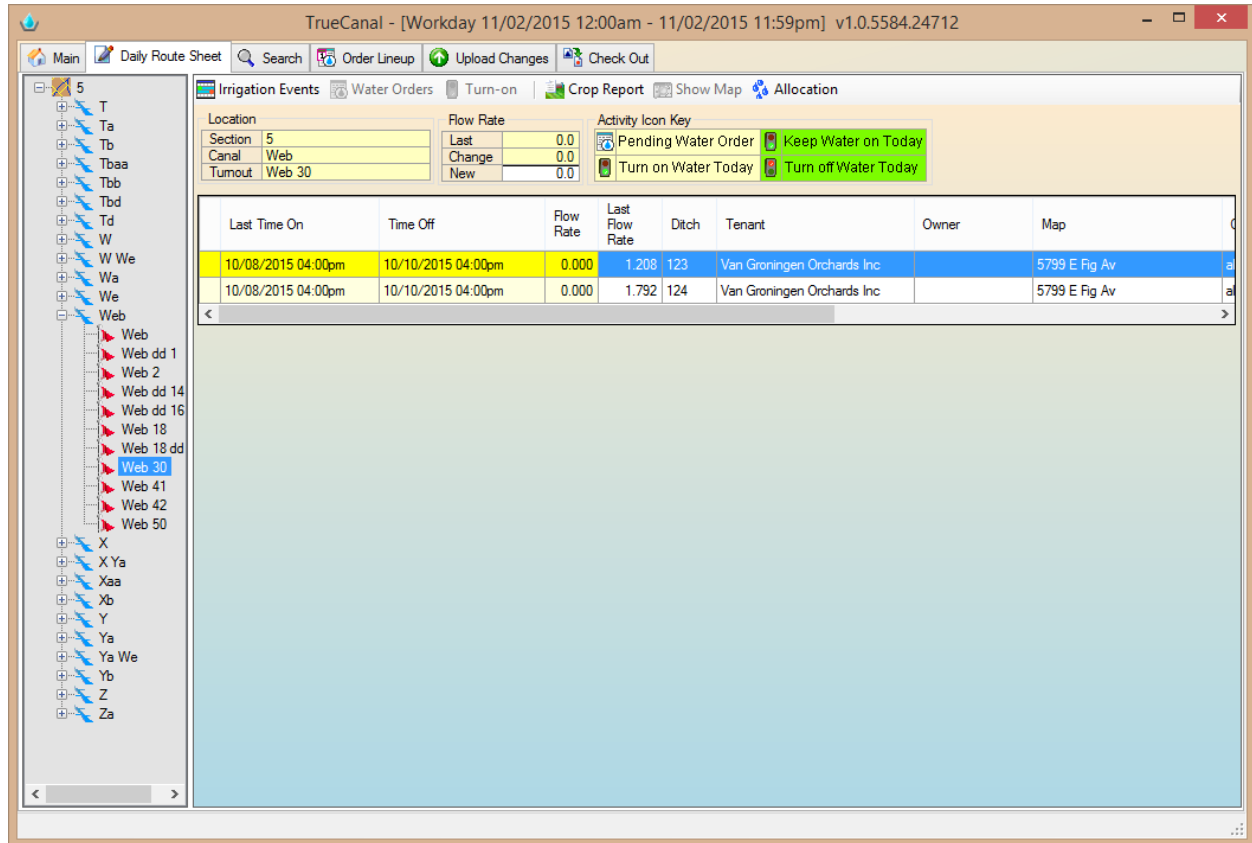

Figure 3-18. TruePoint Water Order Entry Screen

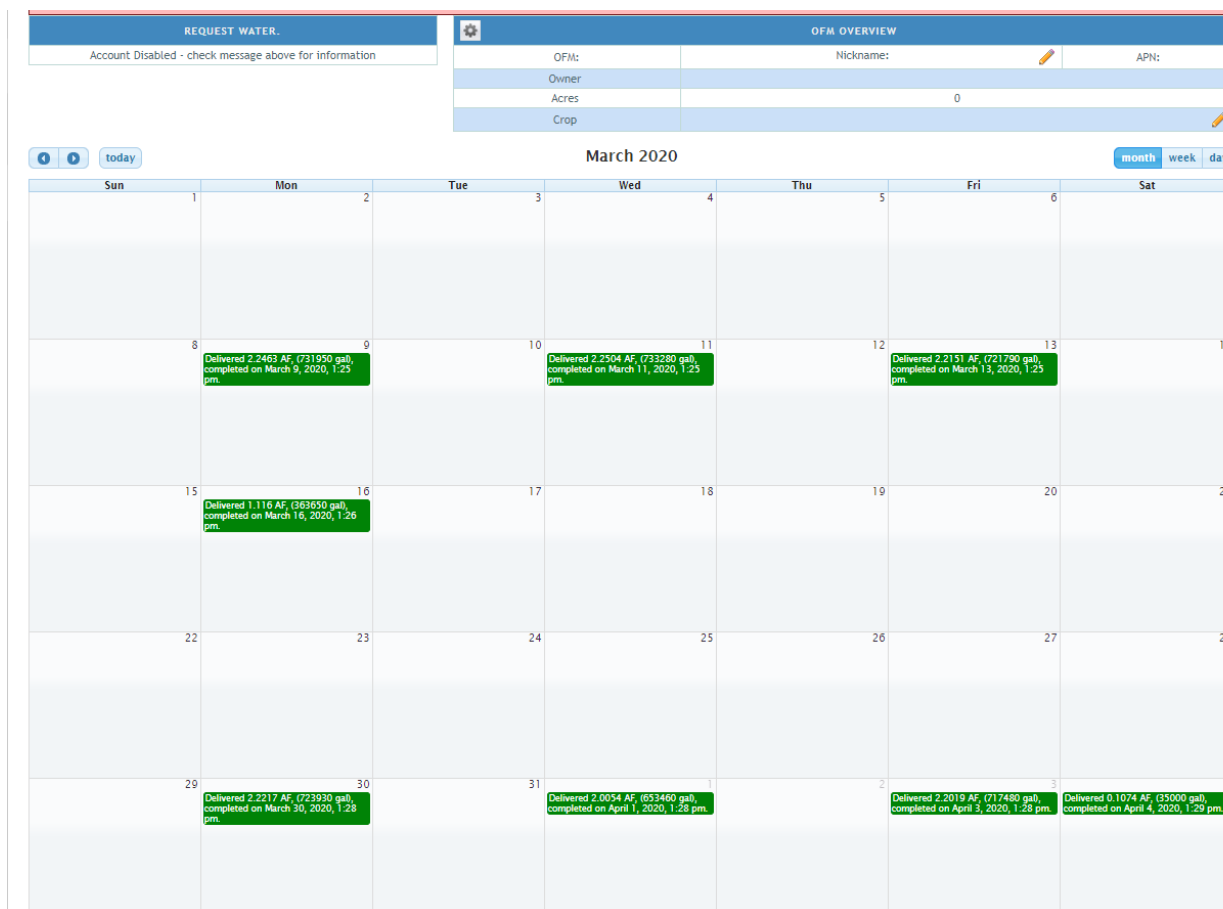

Figure 3-19. On-Farm Meter Portal, Sample Calendar View of Deliveries

3.9 WATER RATE SCHEDULES AND BILLING

In accordance with SBx7-7, SSJID implements a pricing structure based in part on the volume of water delivered. In 2023, the District raised its irrigation rates through a successful Proposition 218 effort. The District approved additional annual maximum rate increase through the 2028 Irrigation season and the Board of Directors will annually approve the actual rate which cannot exceed the maximum rates approved in 2023.

SSJID’s current rate structure has two tiers of volumetric pricing for growers that receive non-pressurized water service. For the 2026 irrigation season, a fixed acreage charge of \$60 per acre charge plus an additional volumetric charge. Growers that receive less than 48 inches per year are charged the ‘Tier 1’ rate, with a volumetric charge of \$10 per af. Growers pay the ‘Tier 2’ rate of \$17.50 per af for any water diverted over 48 inches per year.

Parcels that receive pressurized water from the District’s Division 9 Irrigation Enhancement Project are subject to the fixed acreage charge and volumetric charges plus the Pressurized Irrigation Rate of \$58.12 per acre-foot. The Pressurization rate consists of energy component

and provision for capital assets. On January 27, 2026, there was sufficient protests in opposition to the proposed Pressurized Irrigation Rate which is now effectively capped at the current rate of \$58.12 per acre-foot until such time as the District holds an additional Proposition 218 protest process is conducted.

For properties that do not partake in District surface water irrigation service and irrigate with groundwater, landowners may qualify to sign-off from District services through a Services Abandonment Agreement. These parcels also would not be subject to the charges and rates above, and instead would pay a groundwater recharge fee of \$12 per acre.

Billing practices vary by service type. Customers receiving non-pressurized service are typically billed through the San Joaquin County property tax bills for acreage-based charges, while volumetric charges are billed monthly based on water use. Customers receiving pressurized irrigation service are also billed monthly for both volumetric and pressurization charges. Customers may access billing information and water use data through the District’s online portal, which provides account management and payment capabilities.

3.10 WATER SHORTAGE ALLOCATION POLICIES AND CONTINGENCY PLAN

For a detailed description of the SSJID operational response during water shortage conditions, refer to the District’s Drought Management Plan (Appendix D), which includes discussion of actions implemented during the 2012 through 2016 drought. This section provides a general overview of the District’s approach to water shortage allocation and management.

SSJID recognizes that periodic shortages in available surface water supplies may occur and may be insufficient to meet full agricultural demands. In response, the Board of Directors has developed and implemented a set of “special rules” to guide operations during water supply emergencies. These rules are intended to maintain equitable water delivery service while managing limited supplies in a reasonable and beneficial manner. Originally adopted in 1991 and subsequently refined, these provisions provide a flexible framework that may be adjusted over time based on Board direction and prevailing conditions.

Historically, SSJID has managed drought conditions through a combination of reduced surface water deliveries, operational adjustments, and the use of alternative water supplies, including groundwater. Compliance with SGMA requires that groundwater resources be managed to avoid undesirable results, which may constrain the future availability of groundwater. Accordingly, future drought management actions will continue to emphasize the efficient and economical delivery of available surface water supplies and ensuring that groundwater continues to be a supplemental source of water for District growers while also aligning with basin-wide groundwater sustainability objectives.

Current and past surface water shortage contingency actions are summarized below. These measures provide SSJID with operational flexibility to respond to varying levels of water supply availability, although specific actions implemented in any given year may vary based on hydrologic conditions, regulatory requirements, and Board policy direction. The District has found that implementation of a per-parcel drought allocation (e.g., the 36-inch allocation utilized in 2015) can be an effective method to manage limited supplies and may consider similar approaches in future shortage conditions.

In 2021, severe drought conditions threatened much of California. Fortunately, hydrologic conditions particularly in the Stanislaus River Basin were sufficient to only require voluntary reduction in District agricultural water use. SSJID messaged heavily the importance of using water efficiently and to reduce waste if at all possible. District Division Managers were also tasked with ensuring minimal operational spills.

Potential drought response measures include:

- Establishing a per-parcel drought allocation limit based on available supply
- Reducing the maximum water surface elevation of Woodward Reservoir to minimize evaporation and seepage losses
- Delaying the start date of the irrigation season
- Implementing variable water delivery rotation schedules
- Establishing maximum time limits for flood irrigation
- Implementing irrigation quantity limits for pressurized systems
- Utilizing alternative supply sources (e.g., District wells, leased private pumps, or other available supplies), as consistent with groundwater sustainability requirements
- Allowing inter-parcel transfers and voluntary fallowing, subject to administrative deadlines
- Enforcing Tier 2 service agreement provisions

As implementation of the Eastern San Joaquin GSP continues, the District will expand its capabilities to both estimate and track groundwater recharge and groundwater extractions both at the District scale and at the Subbasin scale. As described in the Water Budget section of this AWMP, the Eastern San Joaquin Groundwater Authority basin has experienced periods of groundwater level decline and reductions in groundwater storage. Within this regional context, the South San Joaquin Irrigation District has historically relied on a combination of surface water supplies and conjunctive use operations that, in many years, have contributed to groundwater recharge and reduced reliance on groundwater pumping relative to other areas of the Subbasin.

Accordingly, drought response actions implemented by SSJID will continue to prioritize the use of available surface water supplies and recharge opportunities, while managing groundwater use in coordination with basin-wide sustainability requirements. While groundwater may continue to serve as a supplemental supply during dry conditions, its use will be balanced with the District’s operational practices and the need to support progress toward achieving groundwater sustainability by 2040.

3.11 POLICIES ADDRESSING WASTEFUL USE OF WATER

SSJID actively prohibits the wasteful use of water, as described in Rule No. 10 in its Rules and Regulations, which states:

“Persons wasting water on roads or vacant land, or land previously irrigated, either willfully, carelessly, or on account of defective ditches or inadequately prepared land, or who shall flood certain portions of the land to an unreasonable depth or amount in order to properly irrigate other portions, will be refused the use of water until such conditions are remedied.” [Rule no. 10, pg. 6, SSJID Rules and Regulations]

Enforcement actions include withholding water for willful wasteful use. The District’s policies regarding unauthorized uses of water and enforcement are described in detail in the Rules and Regulations (Appendix B).

Intentionally Left Blank

4 INVENTORY OF WATER SUPPLIES

This section of the AWMP describes the quantity and quality of the water resources available to SSJID.

Water supply volumes presented in this AWMP section are described on a calendar year basis, thus better describing irrigation practices and SSJID operations that support those practices. The irrigation season varies from year to year based on water needs approximately covering the period from March through October. Consequently, the typical irrigation season in SSJID generally straddles two DWR-defined water years (defined as October 1 to September 30). Water year summaries of the complete SSJID water balance are included in Appendix F (DWR Water Budget Reporting Tables).

In this Section 4 (Inventory of Water Supplies) and in the following Section 5 (Water Balance), the following periods are used for the presentation and interpretation of water supply and water use:

1. **2005-2024 Period (Long-Term Historical):** The 2005-2024 data are reflective of longer-term historical SSJID operations and weather conditions. The most complete and accurate water budget for the SSJID service area is available during this 20-year period. The period begins the year that measured spillage from OID was first available (2005), and after the first year a complete water budget was created for the SSJID drainage system (2003). Results are summarized by:
 - a. Annual values for the 20 years between 2005-2024.
 - b. Average annual value over the 2005-2024 period.
 - c. Average annual value by hydrologic year type (see Section 5.4)
2. **20120-2024 Period (Near-Term Historical):** The 2020-2024 data are reflective of recent SSJID operations and weather conditions. During this period, two water years were classified as “wet” according to the hydrologic year type classification (2023, 2024; see Section 5.4), and three water years were classified as “dry.” Results are summarized by:
 - a. Average annual value over 2020-2024, the last five years of operation.
 - b. Minimum and maximum annual values over 2020-2024, depicting the range of values under recent historical conditions.

4.1 OVERVIEW OF WATER SUPPLIES

Since 1909, SSJID has supplied irrigation water to southern San Joaquin County. With the completion of the Nick C. DeGroot Water Treatment Plant at Woodward Reservoir in 2005, SSJID also provides drinking water to the Cities of Tracy, Manteca, and Lathrop.

The water that SSJID utilizes comes primarily from the Stanislaus River watershed. This surface water supply is highly reliable, and is stored or regulated in the Beardsley, Donnels, New Melones, Tulloch, and Woodward Reservoirs. In addition, both the District and private landowners have constructed groundwater production wells that serve primarily to supplement surface water supplies. Precipitation also provides additional soil moisture for agricultural purposes but, because of its unpredictability and limited quantity, is not considered a primary source. Table 4-1 summarizes the water supply volumes available to SSJID over the 2005-2024 period, and Table 4-2 summarizes the percent total water supply available from each source. Surface water and groundwater supplies are discussed in the following sections.

4.2 SURFACE WATER SUPPLY

Table 4-3 provides a summary of the total surface water supply in SSJID, identifying the relative volume derived from each source. The majority of surface water is delivered from New Melones Reservoir through the Joint Supply Canal. Ordered spillage from New Melones Reservoir also enters the SSJID system, primarily during wet years. Additional details and history surrounding SSJID's surface water supply are described below.

4.2.1 Overview

The Stanislaus River is the primary source of water supply for the District. The District's use of water is based on pre-1914 adjudicated and post-1914 appropriative rights that are shared with OID. "Pre-1914 water rights" are titled as such due to their establishment prior to the California Water Commission Act in 1914, and are only acquired by certain actions to protect the beneficial use of water prior to 1914. With these rights, SSJID and OID may change the place and/or purpose of use as long as it does not injure other users, is not being unreasonably used, and is not impacting public trust uses. A 1929 judgment from the San Joaquin County Superior Court adjudicated the districts' pre-1914 water rights and established a summary response for any future challenges of the water rights. SSJID solely holds post-1914 water rights for storage in Woodward Reservoir.

Table 4-1. Summary of Water Supply Volumes in SSJID.

Year	Year Type	Surface Water Supply ¹ (af)	Groundwater Supply ² (af)	Other Water Supply ³ (af)	Total Supply (af)
2005	Wet	204,761	50,936	10,094	265,791
2006	Wet	232,748	52,389	15,337	300,474
2007	Dry	250,650	71,729	6,291	328,669
2008	Dry	252,760	62,761	7,465	322,986
2009	Dry	244,339	58,170	8,176	310,684
2010	Wet	223,463	41,804	10,784	276,050
2011	Wet	228,392	53,304	11,555	293,252
2012	Dry	225,865	68,593	12,619	307,076
2013	Dry	239,700	70,332	6,039	316,071
2014	Dry	213,060	70,080	7,298	290,438
2015	Dry	187,227	89,884	4,579	281,689
2016	Dry	190,754	78,141	9,071	277,965
2017	Wet	200,296	78,537	7,399	286,232
2018	Dry	222,247	68,484	8,261	298,991
2019	Wet	210,206	62,771	10,103	283,079
2020	Dry	251,142	66,044	8,030	325,216
2021	Dry	216,245	80,046	10,016	306,307
2022	Dry	226,438	93,437	8,283	328,158
2023	Wet	200,930	55,087	17,368	273,385
2024	Wet	223,240	67,449	21,413	312,101
2005-2019	Average	222,223	66,999	10,009	299,231
	Wet Year Avg.	215,505	57,784	13,007	286,295
	Dry Year Avg.	226,702	73,142	8,011	307,854
2020-2024	Average	223,599	72,412	13,022	309,033
	Maximum	251,142	93,437	21,413	328,158
	Minimum	200,930	55,087	8,030	273,385

¹ Surface water supply includes Deliveries from Joint Supply Canal and Ordered Spillage.

² Groundwater supply includes District Pumping, Private Pumping, and Pumping for Groundwater Transfer

³ Other Water Supply includes OID Spills to Main Canal, Tributary Inflow, and Stormwater Runoff.

Table 4-2. Summary of Water Supplies in SSJID as a Percentage of Total Supply.¹

Year	Year Type	Surface Water Supply ¹ (%)	Groundwater Supply ² (%)	Other Water Supply ³ (%)	Total Supply (%)
2005	Wet	77%	19%	4%	100%
2006	Wet	77%	17%	5%	100%
2007	Dry	76%	22%	2%	100%
2008	Dry	78%	19%	2%	100%
2009	Dry	79%	19%	3%	100%
2010	Wet	81%	15%	4%	100%
2011	Wet	78%	18%	4%	100%
2012	Dry	74%	22%	4%	100%
2013	Dry	76%	22%	2%	100%
2014	Dry	73%	24%	3%	100%
2015	Dry	66%	32%	2%	100%
2016	Dry	69%	28%	3%	100%
2017	Wet	70%	27%	3%	100%
2018	Dry	74%	23%	3%	100%
2019	Wet	74%	22%	4%	100%
2020	Dry	77%	20%	2%	100%
2021	Dry	71%	26%	3%	100%
2022	Dry	69%	28%	3%	100%
2023	Wet	74%	20%	6%	100%
2024	Wet	72%	22%	7%	100%
2005-2019	Average	74%	22%	3%	100%
	Wet Year Avg.	75%	20%	5%	100%
	Dry Year Avg.	74%	24%	3%	100%
2020-2024	Average	72%	23%	4%	100%
	Maximum	77%	28%	7%	100%
	Minimum	69%	20%	2%	100%

¹ Surface water supply includes Deliveries from Joint Supply Canal and Ordered Spillage.

² Groundwater supply includes District Pumping, Private Pumping, and Pumping for Groundwater Transfer

³ Other Water Supply includes OID Spills to Main Canal, Tributary Inflow, and Stormwater Runoff.

Table 4-3. Surface Water Supply Summary.

Year	Year Type	Deliveries from Joint Supply Canal (af)	Ordered Spillage (af)	Total Surface Water Supply (af)
2005	Wet	204,501	260	204,761
2006	Wet	222,390	10,358	232,748
2007	Dry	249,569	1,081	250,650
2008	Dry	252,483	277	252,760
2009	Dry	244,059	280	244,339
2010	Wet	223,202	260	223,463
2011	Wet	219,289	9,103	228,392
2012	Dry	225,684	181	225,865
2013	Dry	239,670	30	239,700
2014	Dry	213,017	43	213,060
2015	Dry	187,227	0	187,227
2016	Dry	190,662	92	190,754
2017	Wet	199,600	697	200,296
2018	Dry	222,247	0	222,247
2019	Wet	210,206	0	210,206
2020	Dry	251,142	0	251,142
2021	Dry	216,245	0	216,245
2022	Dry	226,438	0	226,438
2023	Wet	200,930	0	200,930
2024	Wet	223,240	0	223,240
2005-2019	Average	221,090	1,133	222,223
	Wet Year Avg.	212,920	2,585	215,505
	Dry Year Avg.	226,537	165	226,702
2020-2024	Average	223,599	0	223,599
	Maximum	251,142	0	251,142
	Minimum	200,930	0	200,930

After the construction of New Melones Reservoir by the U. S. Bureau of Reclamation (USBR), the District entered into the 1988 Agreement and Stipulation with the USBR describing how water was to be allocated between SSJID, OID, and the USBR. Under the 1988 Agreement, SSJID and OID are entitled to receive the first 600,000 acre-feet per year, and in years when inflow to New Melones is less than 600,000 acre-feet, are entitled to receive the actual inflow plus one-third of the difference between 600,000 and the actual inflow, as explained in Section

4.2.5. Water that is unused in any one year may be stored at New Melones in a “conservation account,” up to a total of 200,000 acre-feet, and can be used in certain drought conditions.

4.2.2 Pre-1914 Water Rights and Goodwin Dam

In 1858, Mr. Charles Tulloch, visionary and entrepreneur, built a small diversion dam immediately downstream of the current site of Tulloch Dam to distribute water to the Knights Ferry area. The system was extended down to the valley to serve 6,000 acres reaching as far downstream as Manteca (an area now served by SSJID) and a small area around Oakdale.

Wielding their newly authorized power following SSJID’s formation in 1909, the District entered into a deal with the OID, who had an option on the “Tulloch Rights,” to equally split the purchase of the complete rights from the San Joaquin Canal and Irrigation Company and the Consolidated Stanislaus Water and Power Company for the sum of \$650,000 on April 28, 1910.

After purchasing the “Tulloch Rights”, the districts abandoned the old miners’ diversion dam and began construction of Goodwin Dam (Figure 4-1) in 1912. Goodwin Dam was completed in April of 1913 with a finished height of 80 feet above the bed of the Stanislaus River and a crest length of 500 feet. Main canals were constructed by both districts to deliver water to customers in the valley. A Joint Main Canal (also referred to as the Joint Supply Canal) was constructed on the north



Figure 4-1. Goodwin Dam

side of the river to supply 850 cfs to SSJID and 260 cfs to OID, with construction costs shared in proportion to their respective diversion allotments. Diversions to the two districts separate at a bifurcation point approximately 3.6 miles from the Dam, with SSJID’s diversion continuing to the west and OID’s diversion channeled into Littlejohns Creek.

4.2.3 Woodward Reservoir and Melones Reservoir

Severe water shortages in 1914-1915 prompted a meeting of landowners who approved the use of funds allocated in a 1913 bond issue specifically for construction of a storage reservoir. In 1916, the District completed construction of an earthen dam on the Main Supply Canal that stretched 3,400 feet long and 60 feet high and created the 36,000 acre-feet Woodward Reservoir to provide much needed storage and water regulation.

During dry years, the additional storage provided by Woodward Reservoir afforded SSJID additional rotations as compared to neighboring districts with little or no storage. However, expansion of irrigated acreage and changing crop patterns increased water demand, and in the early 1920s the Board and farmers agreed to allocate funding for an additional reservoir, primarily for winter water storage. In 1925, the two districts began construction of Melones Dam, which would provide storage capacity of 112,500 af in Melones Reservoir. The dam was completed by the end of 1926, and each District was provided with 51,250 af of stored water, accounted as a post-1914 appropriation. At the time the water supply from Melones Reservoir was sufficient for the needs of SSJID, but increasing irrigated acreage and changes in cropping patterns, along with concern over deficiency in dry years, would prompt the Board of Directors to actively seek supplemental water. Some of this supplemental water was supplied through the installation of groundwater wells by the District in the early 1920s to control the high groundwater table, primarily in the western portions of SSJID.

4.2.4 Tri-Dam Project

By the mid-1940s SSJID and OID were again searching for additional reservoir storage capacity to serve their constituents. In 1948, the districts jointly formed the Tri-Dam organization and selected three reservoir sites to be collectively named the Tri-Dam Project. Donnell's and Beardsley Reservoirs were constructed on the Middle Fork of the Stanislaus River with storage capacities of 64,500 and 97,500 af, respectively. Tulloch Reservoir was constructed above Goodwin Diversion Dam with a storage capacity to 68,400 af. The Tri-Dam facilities – including hydropower – became operational in 1957. Goodwin Diversion Dam was also raised 7 feet in 1955 to bring its total storage capacity to 500 af. Donnell's and Beardsley Reservoirs have post-1914 rights to store water.

4.2.5 New Melones Reservoir

Prior to the construction of the New Melones Dam and Reservoir by the USBR, and as part of the condemnation of the (Old) Melones Reservoir, the joint districts entered into a 1972 Stipulation and Agreement, whereby the exercise of the joint districts' water rights was modified by an allocation agreement between the USBR and the districts for 654,000 af per year. In 1988, the joint districts renegotiated the 1972 Stipulation and Agreement with the USBR. In the 1988 Agreement, the districts receive a maximum of 600,000 af per year. Based on an even split of the available supply, this equates to 300,000 af that are available to both SSJID and OID each year. In reaching this Agreement, the joint districts agreed to relinquish 54,000 af per year of water in exchange for an obligation from the USBR to make up 33 percent of any deficiency below 600,000 af per year. In years when the inflow into New Melones Reservoir is less than 600,000 af, the District's available water supply under the 1988 Agreement is determined as set forth in Equation 4-1:

$$\text{Annual SSJID + OID Supply} = \text{Inflow} + [600,000 \text{ af} - (\text{inflow})] \times 0.33 \quad [4-1]$$

To determine the probability that SSJID’s available water supply under the 1988 Agreement will be less than 300,000 af, an analysis was performed based on historical water year inflows for the period from 1895 to 2014. New Melones inflows over this period varied from 129,300 af in water year 1977 to 2,800,000 af in water year 1907 with an average of 1,136,000 af over the full 120-year record (Figure 4-2). The running 30-year average varies from 996,000 af for 1985 through 2014 to 1,300,000 af for 1895 through 1924. Based on the analysis, it is estimated that SSJID will receive its full supply in 79 out of 100 years and will receive at least 267,000 af in 90 out of 100 years (Figure 4-3). The minimum supply SSJID will likely receive in any year is approximately 225,000 af, assuming there are sufficient supplies in the District’s conservation account at New Melones (established by the 1988 Agreement) to make up the difference between the result of Equation 4-1 and 225,000 af.

Based on recent hydrology (1985-2014), SSJID is expected to receive its full supply in approximately 60% of years, and at least 253,000 af in 90% of years. In spite of this decrease in reliability, the minimum supply SSJID will likely receive in any year is still approximately 225,000 af.

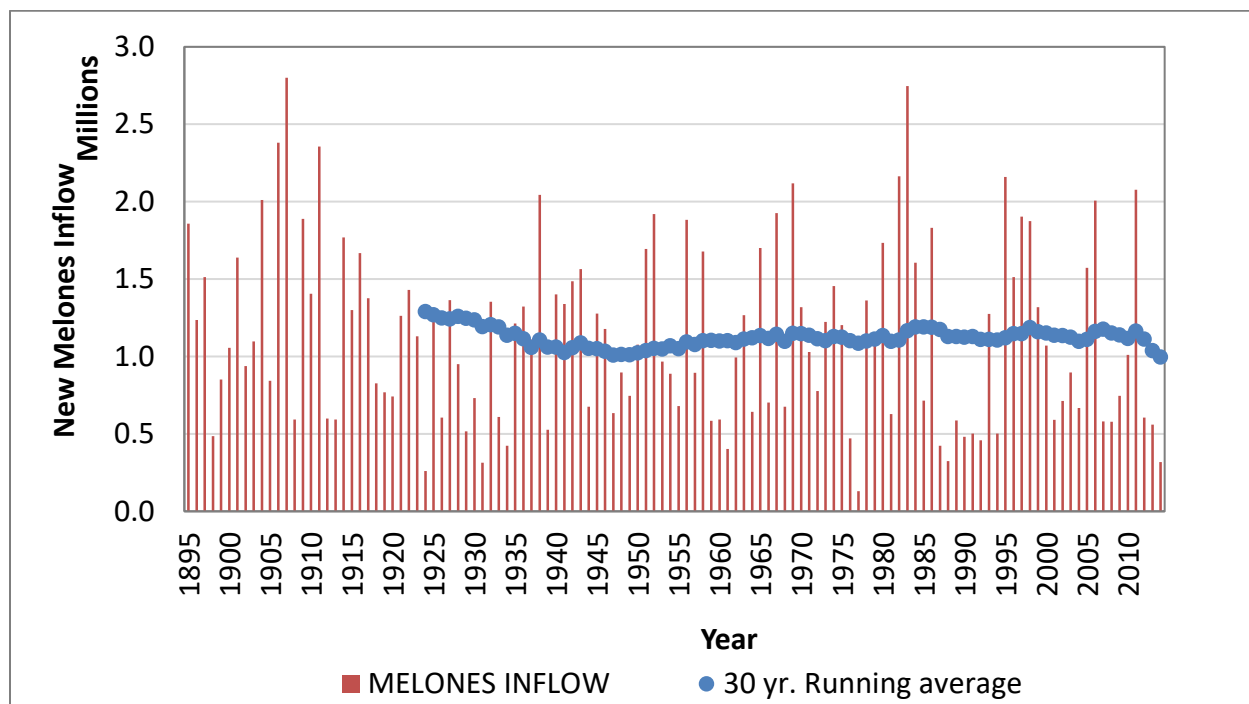

Figure 4-2. New Melones Inflow (1895 through 2014 Water Years)

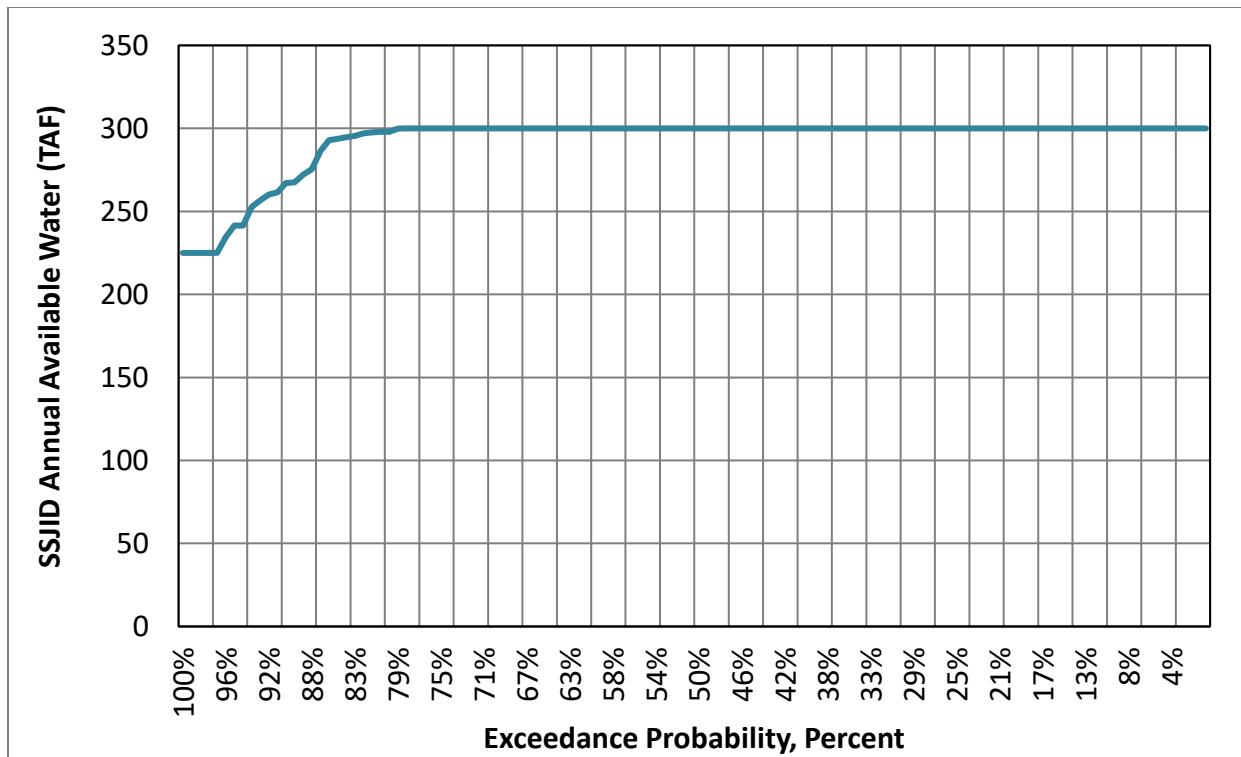

Figure 4-3. Exceedance Probability of SSJID Stanislaus River Water Supply

4.3 GROUNDWATER SUPPLY

Table 4-4 provides a summary of the total groundwater supply in SSJID, identifying the relative volume derived from each source. The majority of groundwater results from private pumping, or pumping from privately owned wells. Approximately 3,000 af to 6,000 af per year is also pumped by the District. In 2015 and 2022, as a humanitarian response to unprecedented drought conditions and the threat of a local fire emergency, approximately 1,000 af and 1,800 af respectively, of additional groundwater was pumped and transferred to the Mountain House Community Services District (incorporated as City of Mountain House in 2024) in southwestern San Joaquin County.

Table 4-4. Groundwater Supply Summary.

Year	Year Type	District Pumping (af)	Private Pumping (af)	Pumping for Groundwater Transfer (af)	Total Groundwater Supply (af)
2005	Wet	5,974	44,962	0	50,936
2006	Wet	5,239	47,150	0	52,389
2007	Dry	6,024	65,705	0	71,729
2008	Dry	5,656	57,105	0	62,761
2009	Dry	4,917	53,253	0	58,170
2010	Wet	3,078	38,725	0	41,804
2011	Wet	2,601	50,703	0	53,304
2012	Dry	4,399	64,194	0	68,593
2013	Dry	6,120	64,212	0	70,332
2014	Dry	5,388	64,692	0	70,080
2015	Dry	5,264	83,613	1,007	89,884
2016	Dry	3,699	74,442	0	78,141
2017	Wet	3,938	74,599	0	78,537
2018	Dry	3,229	65,255	0	68,484
2019	Wet	4,538	58,232	0	62,771
2020	Dry	4,630	61,413	0	66,044
2021	Dry	5,348	74,699	0	80,046
2022	Dry	5,043	86,585	1,809	93,437
2023	Wet	3,660	51,426	0	55,087
2024	Wet	2,900	64,549	0	67,449
2005-2024	Average	4,582	62,276	141	66,999
	Wet Year Avg.	3,991	53,793	0	57,784
	Dry Year Avg.	4,976	67,931	235	73,142
2020-2024	Average	4,316	67,734	362	72,412
	Maximum	5,348	86,585	1,809	93,437
	Minimum	2,900	51,426	0	55,087

4.3.1 Groundwater Supply Wells

The District has more than 20 deep wells located mainly in the southwestern portion of its service area that are operated to alleviate shallow groundwater conditions there (Figure 4-4). Shallow groundwater levels can cause harm to crops if root zones are saturate or seldom drained. Groundwater also provides increased water supply flexibility by allowing operators to access additional flow by turning on one or more pumps. Pumped groundwater is directly discharged into laterals, and a combination of groundwater and surface water is then delivered to growers in the area. In 2018, two new District wells came online near the Sam Bologna Reservoir to supplement Division 9 supplies.



Figure 4-4. SSJID Groundwater Well

Annual production of District wells ranges between approximately 2,600 and 6,200 af and are operated as needed as opposed to continuously. All deep well pumps are remotely monitored.

SSJID production wells are tested for pump efficiency as needed or if a pump falls significantly below its design capacity. The need for replacement or rehabilitation of each well is periodically assessed, and improvement actions are prioritized to provide the greatest benefit relative to the cost.

4.3.2 Subbasin Characteristics

SSJID overlies the southern portion of the Eastern San Joaquin Subbasin (Basin 5-22.01 under California’s Bulletin 118) of the San Joaquin Valley Groundwater Basin. The Eastern San Joaquin Subbasin is bounded by the Mokelumne River to the north, the Stanislaus River to the south, the San Joaquin River to the west and the Sierra Nevada foothills to the east. The Subbasin underlies the urban areas of Manteca, Ripon, Escalon, Lodi and Stockton, which utilize groundwater for a sizable portion of their drinking water supplies (Figure 4-5).

The subbasin formation is generally characterized by stream deposited sands, gravels, silts and clays. In the western portion of the District, localized layers of clay and silt result in zones of perched water (Kreinberg, 1994). Four permeable water bearing formations are found to exist within the District’s boundaries: the Modesto Formation, the Riverbank Formation, the Laguna Formation, and the Mehrten Formation. Water for agricultural use is typically extracted from the first and second layers. These formations exist at varying depths and thicknesses, and produce yields typically ranging from 650 – 1,500 gpm (DWR, 2006). Irrigation and municipal well depths range from approximately 80 to 800 feet with an average depth of 350 feet.

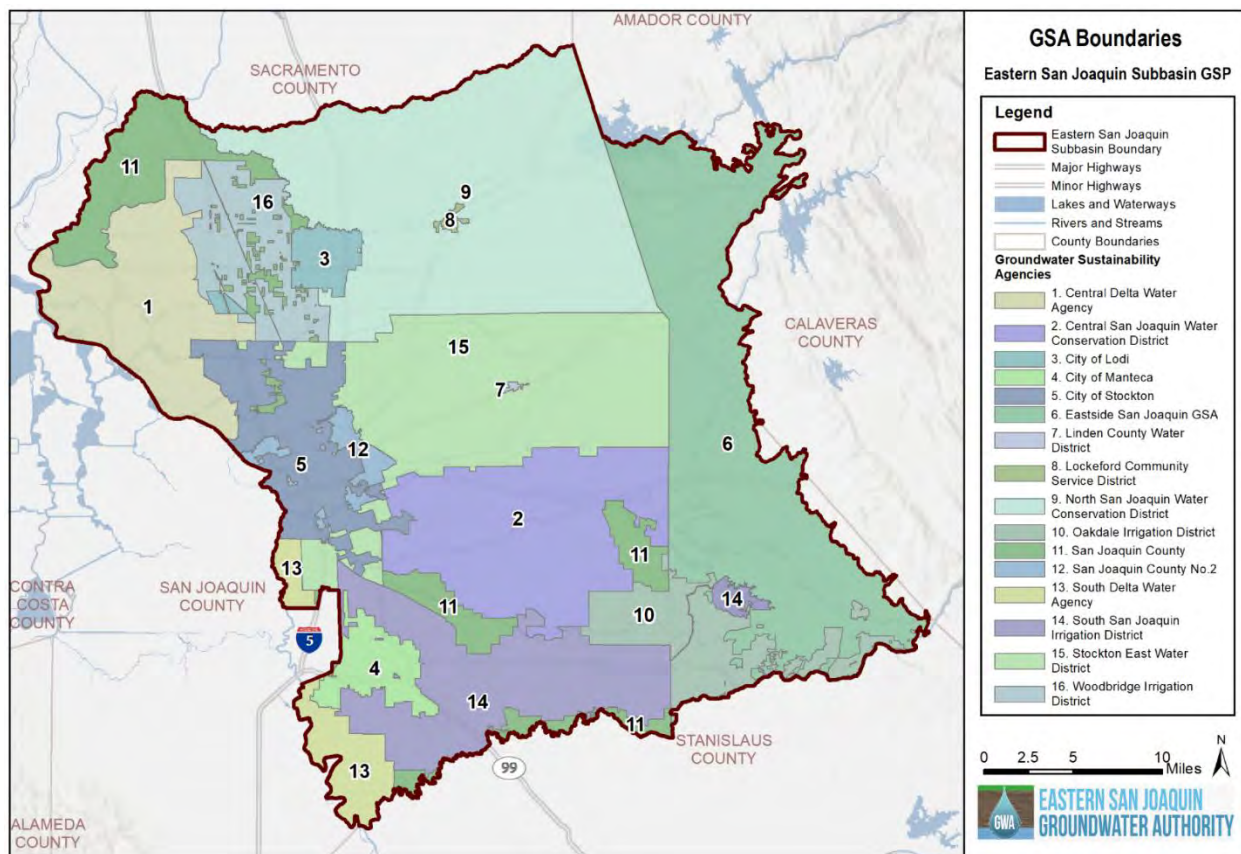

Figure 4-5. Eastern San Joaquin Groundwater Subbasin and Groundwater Sustainability Agency Boundaries (Eastern San Joaquin Subbasin GSP, 2024)

4.3.3 Sustainable Groundwater Management

SSJID, as part of the South San Joaquin Groundwater Sustainability Agency (SSJGSA), is a member of the Eastern San Joaquin Groundwater Authority (ESJGWA). The ESJGWA was established in response to the Sustainable Groundwater Management Act of 2014 (SGMA), and functions to organize, coordinate, and execute SGMA compliance efforts among the 16 GSA members in the Eastern San Joaquin Subbasin to achieve groundwater sustainability by 2040. SSJID’s involvement in the SSJGSA and the ESJGWA has contributed towards the adoption and submittal of the 2022 Revised Groundwater Sustainability Plan (GSP) which was approved by DWR. The ESJGWA submitted an Amended 2024 GSP and Periodic Evaluation to DWR in January 2025 and is awaiting review by DWR.

As documented in the Amended 2024 GSP, seepage and deep percolation associated with South San Joaquin Irrigation District (SSJID) surface water facilities and surface water deliveries remains a significant source of groundwater recharge for the District. In addition, SSJID’s conjunctive use framework—where surface water deliveries reduce reliance on groundwater pumping while simultaneously contributing to recharge—provides substantial District benefits.

Generally, groundwater overdraft persists in areas north of SSJID where surface water availability and delivery is limited. This has resulted in a pronounced cone of depression that has altered regional groundwater flow patterns, with flow now trending northward from SSJID. Modeling of groundwater levels shows that climate change could potentially exacerbate conditions of overdraft. SSJID will continue to play a role in Subbasin-wide efforts to comply with SGMA and to support effort by other GSAs to mitigate conditions of overdraft through projects and management actions. A link to the ESJGWA Amended 2024 GSP can found in Appendix E.

4.3.4 Subbasin Groundwater Use and Recharge

The Amended 2024 GSP quantifies groundwater conditions in the Eastern San Joaquin Subbasin. Modeling indicates that an additional 95,000 af/yr of additional supplemental surface water would need to be recharged subbasin-wide to bring eliminate overdraft and bring sustainability. An additional 166,000 af/yr would be needed using the 2070 Central Tendency dataset for SGMA climate change analysis as recommended by DWR.

The District continues to exert its rights to surface water recharged from its facilities such as canals, reservoirs, and laterals, and also the groundwater saved through conjunctively managing surface and groundwater supplies. This supply is needed for existing groundwater users within the District and as a future drought supply.

4.4 OTHER WATER SUPPLIES

In addition to Stanislaus River water and groundwater supplies, the District is receptive to the reuse of municipal and industrial (M&I) effluent⁵ and in certain situations, accepts tailwater from irrigators who produce tailwater and do not have access to a drain.

Table 4-5 provides a summary of the other supplies available in SSJID, identifying the relative volume derived from each source. SSJID captures boundary outflows from OID and individual irrigators in the MDC and MSC. OID monitors and reports spillage volumes that enter the SSJID system, which totals approximately 3,000 af per year, on average. Other stormwater inflow and tributary runoff provide an average of 2,300 af and 3,600 af, respectively, to the SSJID service area each year. The District is also open to evaluating the potential for municipal recycled water as a possible solution to river discharges and as a supplemental irrigation supply source. Municipal stormwater discharges are also possible sources of water however, the timing of availability makes this source of water infeasible for most of the irrigation season.

⁵ There is currently no known source of M&I effluent within SSJID's service area that is not otherwise beneficially used.

4.5 WATER QUALITY MONITORING

SSJID has historically performed monitoring of surface water and groundwater quality within its service area and the surrounding areas under a combination of District and regional water management activities. These activities are described in greater detail below.

Table 4-5. Other Water Supply Summary.

Year	Year Type	OID Spills to Main Canal (af)	Stormwater Runoff (af)	Tributary Inflow (af)	Total Other Water Supply (af)
2005	Wet	2,645	2,895	4,554	10,094
2006	Wet	3,888	2,573	8,876	15,337
2007	Dry	3,883	1,115	1,292	6,291
2008	Dry	3,243	1,541	2,681	7,465
2009	Dry	2,470	2,018	3,687	8,176
2010	Wet	3,078	3,463	4,244	10,784
2011	Wet	2,932	2,111	6,512	11,555
2012	Dry	4,035	2,483	6,101	12,619
2013	Dry	4,419	927	693	6,039
2014	Dry	2,553	2,818	1,928	7,298
2015	Dry	1,732	1,611	1,235	4,579
2016	Dry	1,934	3,445	3,692	9,071
2017	Wet	2,284	2,108	3,007	7,399
2018	Dry	3,402	2,669	2,190	8,261
2019	Wet	3,411	2,960	3,732	10,103
2020	Dry	3,061	1,410	3,560	8,030
2021	Dry	3,061	2,388	4,567	10,016
2022	Dry	3,061	2,285	2,937	8,283
2023	Wet	5,275	3,642	8,451	17,368
2024	Wet	13,715	2,723	4,975	21,413
2005-2024	Average	3,704	2,359	3,946	10,009
	Wet Year Avg.	4,654	2,809	5,544	13,007
	Dry Year Avg.	3,071	2,059	2,880	8,011
2020-2024	Average	5,634	2,490	4,898	13,022
	Maximum	13,715	3,642	8,451	21,413
	Minimum	3,061	1,410	2,937	8,030

4.5.1 Surface Water, Other Water, and Source Water Quality Monitoring Practices

Historically, SSJID has performed in-house water quality monitoring of its surface water supply at Woodward Reservoir. This testing is done on a regular basis as part of the District’s WTP

operation. The District's surface water supply is of excellent quality for both drinking water and irrigation.

SSJID participates in regional water quality monitoring through the Central Valley Regional Water Quality Control Board's Irrigated Lands Program by way of membership in the San Joaquin County and Delta Water Quality Coalition, which the District joined in March 2011. Additionally, the District monitors for aquatic pesticides as required by the Statewide General National Pollutant Discharge Elimination System (NPDES) Permit for the Discharge of Aquatic Pesticide for Aquatic Weed Control in Waters of the United States.

4.5.2 Groundwater Supply Monitoring

The District participates in groundwater quality monitoring through the ESJGWA which is a requirement of the Amended 2024 GSP. The ESJGWA monitors 21 wells for water quality semi-annually in the spring and fall. The ESJGWA reports lab results for total dissolved solids (TDS) and chloride, and pH, electrical conductivity (EC), and temperature taken in the field.

In addition, the San Joaquin County Flood Control and Water Conservation District (SJCFCWD) monitors both groundwater levels and groundwater quality at wells throughout San Joaquin County, including SSJID. County staff, sample several wells and test for total dissolved solids (TDS), chloride, and electrical conductivity (EC). The SJCFCWCD produces semi-annual (spring and fall) groundwater reports and publishes these reports on its website (<https://www.sjwater.org/Water-Resources-Management/Groundwater/Groundwater-Reports>).

In general, groundwater quality data is published only in the fall report, following peak production during the summer months. SJCFCWCD has been developing the San Joaquin County Groundwater Data Center (GDC), a web-based interactive tool to make historical groundwater information readily available in individuals and public entities, such as SSJID. Groundwater pumped for irrigation in SSJID is generally of good quality, with a few localized areas of elevated TDS values.

5 WATER BALANCE

5.1 INTRODUCTION

This section describes the various water uses and water supplies within SSJID, providing an overall picture of how SSJID's water supplies are used to meet water demands with the District's service area. The detailed water balance is provided to quantify all significant inflows and outflows of water to and from key accounting centers within the District. For each accounting center, a detailed, multi-year water balance covering the period from 2005 to 2024 is presented.

The water uses and water balances are discussed in relation to hydrologic conditions within SSJID, which vary from year to year. Key hydrologic drivers of water management in a given year include available surface water supply under the 1988 Agreement and Stipulation with the USBR, which is based on New Melones Reservoir inflows; precipitation within the SSJID service area; and atmospheric water demand.

Water budget results presented in this AWMP section are provided on a calendar year basis. The irrigation season varies from year to year based on water needs, but approximately covers the period from March through October. Consequently, the typical irrigation season in SSJID generally straddles two DWR-defined water years (defined as October 1 to September 30). By keeping the March through October irrigation season in one year, the calendar year water budget better describes irrigation practices and SSJID operations that support those practices. Water year summaries of the complete SSJID water balance are included in Appendix F.

5.2 WATER BALANCE OVERVIEW

In 2020, SSJID developed and began implementing a semi-automated water balance application. This application imports and compiles data collected and reported by SSJID staff that quantify the District's water supply inflows and water deliveries, among other information. The application then automatically combines these imported data with other data describing weather parameters, reservoir and canal characteristics, and crop water use and root zone characteristics to automatically compute the SSJID water balance. The resulting water balance is then reviewed and edited, as needed, by SSJID staff.

The semi-automated water balance application will afford significant improvements over past water balances, allowing District staff to quantify all major flows into, through, and out of the District's reservoirs, canals, drains, and irrigated lands with greater speed, lower effort, and greater consistency from year to year. Altogether, these advantages greatly support the District's efforts to efficiently and effectively manage its water resources.

This section describes the general water balance methodology and structure used in SSJID, with a brief description of the major flow paths and data sources used in the improved semi-

automated water balance application. Additional detail describing the data sources and uncertainty associated with each flow path are described in the following section.

5.2.1 General Water Balance Methodology

The District's semi-automated water balance application has six⁶ accounting centers through which agricultural water supplies are conveyed or used. These include three separate accounting centers for the SSJID distribution system, and one accounting center each for Woodward Reservoir, the irrigated lands within the SSJID boundary, and the SSJID drainage system. A schematic of the water balance structure is provided in Figure 5-1. The accounting centers for SSJID are:

1. Main Supply Canal (MSC) Above Woodward Reservoir
2. Woodward Reservoir
3. MSC below Woodward Reservoir and Main Distributary Canal (MDC)
4. District Laterals
5. Irrigated Lands
6. Drainage System

In general, flow paths are quantified on a monthly basis using District data sources, weather data sources, and root zone water budget model results (described in Section 5.3). For each accounting center, all but one flow path is quantified independently based on measured data, calculations, or estimates. The remaining flow path is then calculated on a monthly time step based on the principle of conservation of mass (Equation 5-1), which states that the difference between total inflows and outflows to an accounting center for a given period of time is equivalent to the change in water stored within that accounting center.

$$\text{Inflows} - \text{Outflows} = \text{Change in Storage (monthly time step)} \quad [5-1]$$

⁶ A seventh accounting center representing urban lands in the SSJID service area is also included in the semi-automated water balance application. This accounting center is included to support SSJID's many other water balance reporting needs, including Urban Water Management Plan (UWMP) reporting and SGMA reporting. Flows through the urban lands accounting center are not reported in this AWMP water balance except in cases where they interact with the six accounting centers described herein.

- MSC = Main Supply Canal
- MDC = Main Distribution Canal
- ⊗ = Measured Record
- ⊙ = Partially Measured Record
- 1 = Closure during Winter months
- 2 = Closure during Summer months
- 3 = Mountain House in 2015
- * = Complete Balance not performed
- ← = Accounting Center Closure Term
- ← = IDC Model Output
- ← = TruePoint
- ← = SSJID Records

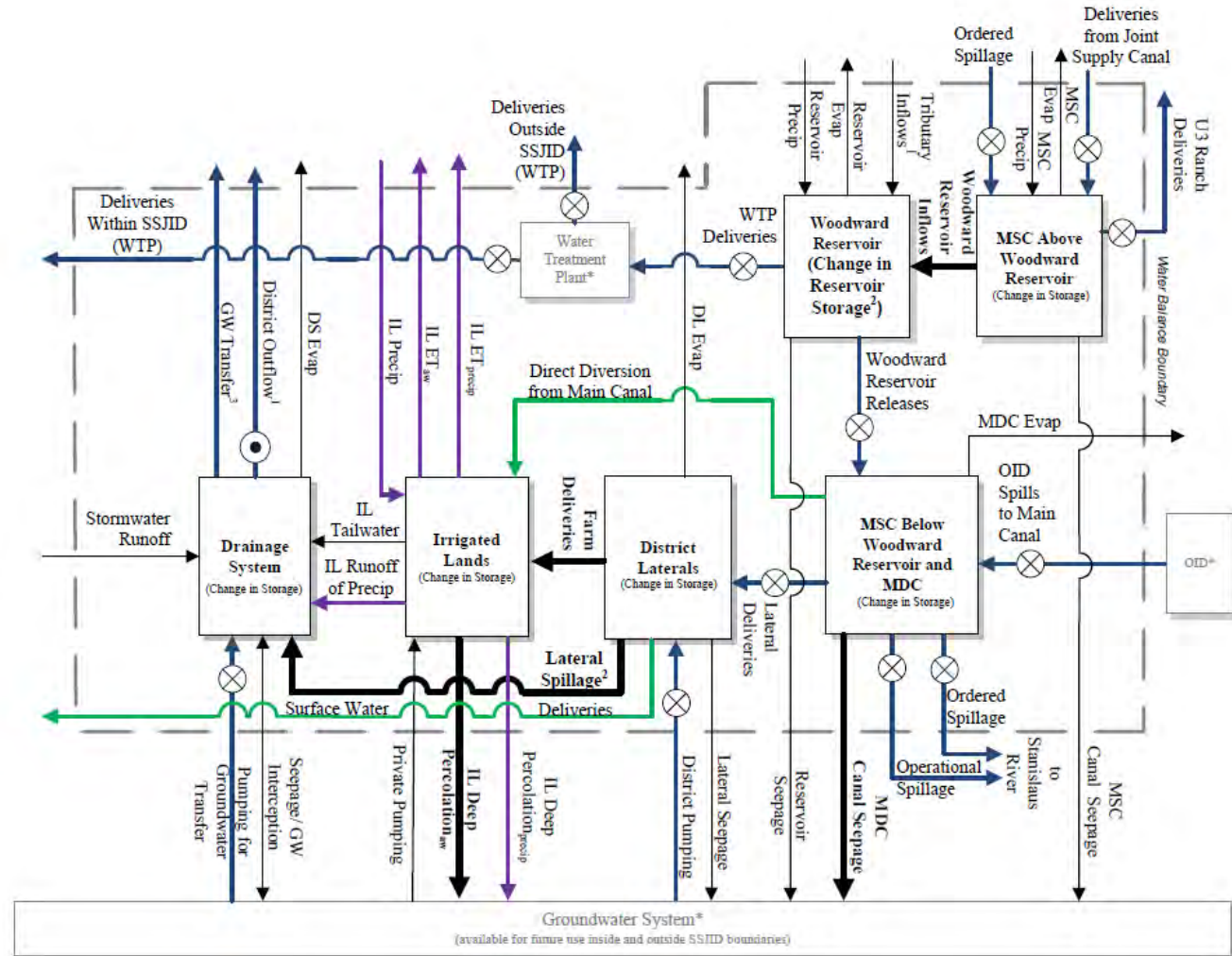

Figure 5-1. SSJID Water Balance Structure

Intentionally Left Blank

The flow path that is calculated as the difference between all other inflows and outflows in the accounting center is referred to as the “closure term” because the mass balance equation is solved or “closed” for the unknown quantity. The closure term is selected based on consideration of the availability of data or other information to support an independent estimate of each flow path, as well as the volume of water representing the flow path relative to the size of other flow paths. Generally speaking, the largest, most uncertain flow path is selected as the closure term.

5.2.2 Irrigated Lands Root Zone Water Budget Model and Improved Crop Coefficients

A daily root zone water balance model and improved crop coefficients derived from ET estimated by a remotely sensed energy balance that reflect water use reductions due to crop stressors were used to develop an accurate and consistent calculation of historical crop ET (ET_c) and ET from applied water (ET_{aw}). A daily root zone water balance is a generally accepted and widely used method to estimate effective rainfall (ASCE, 2015 and ASABE, 2007). The water balance reported in the District’s 2012 AWMP used a monthly, volume-based root zone water balance to parse the ET_a into ET_{aw} and ET from precipitation (ET_{pr}). The District’s updated water balance was improved by using the daily, physical-based Integrated Water Flow Model Demand Calculator (IDC) version 2015.0.0036 (DWR, 2015). IDC is the root zone component of the California Department of Water Resources Integrated Water Flow Model (IWFm). In this application, IDC is independent of IWFm. An advantage of using IDC as the District’s root zone model is that it can be used as the foundation for coupling the SSJID water balance to a groundwater model and, perhaps, eventually an integrated hydrologic model in the future.

Additionally, improved crop coefficients were derived from actual ET (ET_a) estimated by Mapping EvapoTranspiration at high Resolution with Internalized Calibration (METRIC) for two recent years. Remotely sensed energy balance ET results account for the effect of salinity, deficit irrigation, disease, poor plant stands, and other stress factors on crop ET. Studies by Bastiaanssen, et al. (2005), Allen, et al. (2007 and 2011), Thoreson, et al. (2009) and others have found that when performed by an expert analyst, seasonal ET_a estimates by these models are within plus or minus five percent of actual ET.

5.3 WATER BUDGET CALCULATION AND UNCERTAINTY

Monthly volumes for the flow paths shown in Figure 5-1 were estimated based on direct measurements or based on calculations using measurements and other data. As described previously, flow paths not estimated independently were calculated as the closure term of each accounting center.

The data sources and methodologies used to quantify these flow paths are described in the sections below, organized by accounting center. The flow path names described in these sections correspond to the flow paths identified in Figure 5-1. Unless otherwise specified, the change in

storage of canals, laterals, and drains is assumed to be zero across the duration of a complete calendar year. A discussion of flow path uncertainty is provided below.

5.3.1 Main Supply Canal Above Woodward Reservoir

For the “Main Supply Canal (MSC) above Woodward Reservoir” accounting center, the closure term for the entire 2005-2024 water budget period was the Woodward Reservoir Inflows.

Other flow paths were quantified as follows:

- Deliveries from Joint Supply Canal: measured data (rated section).
- Ordered Spillage: measured data (rated section).
- MSC Precip: calculated from daily Manteca CIMIS station precipitation data multiplied by surface area.
- MSC Canal Seepage: calculated from seepage coefficient of soils underlying the canal, estimated wetted area, and wetted duration.
- MSC Evap: calculated from daily Manteca CIMIS station reference ET (ET_0) multiplied by the open water surface area and an open water surface evaporation coefficient (1.1) (UCCE Extension Leaflet).
- U3 Ranch Deliveries: measured data (one slide gate, one weir).

5.3.2 Woodward Reservoir

For the “Woodward Reservoir” accounting center, the closure term differed between the winter and summer (irrigation season) months. During the summer, the Change in Reservoir Storage was the accounting center closure term. During the winter months, Tributary Inflows were the accounting center closure term. Other flow paths and time periods were quantified as follows:

- Woodward Reservoir Inflows: calculated as closure of the “MSC above Woodward Reservoir” accounting center.
- Tributary Inflows (Summer Months): estimated as zero (minimal summer runoff).
- Change in Reservoir Storage (Winter Months): estimated from water level data and capacity-stage relationship.
- Woodward Reservoir Releases: measured data (rated section).
- Water Treatment Plant (WTP) Deliveries: measured data (KROHNE INFL meter - FIT-1320-1 & FIT-1320-2).
- Reservoir Precip: calculated from daily Manteca CIMIS station precipitation data multiplied by surface area.
- Reservoir Seepage: calculated from seepage coefficient of soils underlying the reservoir and the wetted area of the reservoir. The seepage coefficients are based on change in storage during times when there were no inflows to or outflows from the reservoir.

- Reservoir Evap: calculated from daily Manteca CIMIS station ET_o multiplied by the open water surface area and an open water surface evaporation coefficient (1.1) (UCCE Extension Leaflet)

5.3.3 Main Supply Canal Below Woodward Reservoir and Main Distributary Canal

For the “MSC Below Woodward Reservoir and Main Distributary Canal (MDC)” accounting center, the closure term was MDC Canal Seepage. Other flow paths and time periods were quantified as follows:

- Woodward Reservoir Releases: measured data (rated section)
- OID Spills to Main Canal: measured data (OID records)
- Ordered Spillage (to Stanislaus River): measured data (rated section)
- Operational Spillage (to Stanislaus River): measured data (long-crested weir)
- Lateral Deliveries: measured data (primarily SonTek IQ flow meters at lateral headings)
- Direct Diversion from Main Canal: estimated based on distribution system flows and recorded in TruePoint
- MDC Evap: Calculated from daily Manteca CIMIS station ET_o multiplied by the open water surface area and an open water surface evaporation coefficient (1.1) (UCCE Extension Leaflet)

5.3.4 District Laterals

For the “District Laterals” accounting center, the closure term was Farm Deliveries to irrigated agricultural land. This closure is compared to TruePoint delivery data as a validation of the accuracy of delivery measurements stored in TruePoint. Other flow paths and time periods were quantified as follows:

- Lateral Deliveries: measured data (primarily SonTek IQ flow meters at lateral headings)
- Lateral Spillage: calculated as closure of the “Drainage System” accounting center
- District Pumping: measured data (propeller meters)
- Surface Water Deliveries (to Urban Lands): estimated based on distribution system flows and recorded in TruePoint (deliveries are to urban areas in Ripon)
- Lateral Seepage: calculated based on the wetted area, wetted duration, and an assumed seepage coefficient 0.05 feet per day for concrete lining (USBR, 1994)
- District Laterals (DL) Evap: Calculated from daily Manteca CIMIS station ET_o multiplied by the open water surface area and an open water surface evaporation coefficient (1.1) (UCCE Extension Leaflet)

5.3.5 Irrigated Lands

For the “Irrigated Lands” (IL) accounting center, the closure term was deep percolation of applied water, or “IL Deep Percolation_{aw}.”

Other flow paths and time periods were quantified as follows:

- Farm Deliveries: calculated as closure of the “District Laterals” accounting center
- Direct Diversion from Main Canal: measured data (recorded in TruePoint)
- Private Pumping: Estimated as the additional water necessary to meet IL ET_{aw}
- Irrigated Lands Evapotranspiration of Applied Water (IL ET_{aw}): IDC output (see description below)
- Irrigated Lands Evapotranspiration of Precipitation (IL ET_{precip}): IDC output (see description below)
- Irrigated Lands Precipitation (IL Precip): IDC output (see description below)
- Irrigated Lands Tailwater (IL Tailwater): IDC output (see description below)
- Irrigated Lands (IL) Runoff of Precip: IDC output (see description below)
- Irrigated Lands Deep Percolation of Precipitation (IL Deep Percolation $_{precip}$): IDC output (see description below)
- Change in Storage: change in root zone storage is an IDC output (see description below)

5.3.5.1 IDC Root Zone Water Budget Results

The primary outflow from irrigated lands is crop evapotranspiration (ET). Crop ET may be derived from applied irrigation water or from precipitation. The Integrated Water Flow Model – Demand Calculator (IDC), developed by the DWR and introduced in Section 5.2.2, is a root zone water balance model that partitions total crop ET into ET_{aw} and ET_{precip} .

Primary inputs into the IDC model include: crop evapotranspiration, precipitation, and soil parameters, such as hydraulic conductivity, field capacity, permanent wilting point, etc. Nine crop groups were modeled: alfalfa, almonds, corn, grapes, idle, other crops, pasture, peaches, and walnuts. Soil parameters were based on two soil types: sandy loam and loamy sand, resulting in eighteen unique crop-soil combinations. ET_a was estimated from 2005 to 2024 based on Mapping EvapoTranspiration at high Resolution with Internalized Calibration (METRIC) derived grass reference crop coefficients and grass reference evapotranspiration from the Manteca CIMIS station. Combining IDC model outputs with annual crop acreage summaries provided by the District, volume of precipitation, ET_{aw} , ET_{precip} , runoff, and deep percolation of precipitation was incorporated into the water balance.

5.3.6 **Drainage System**

For the “Drainage System” accounting center, the summer closure term was Lateral Spillage and the winter closure term was District Outflow. Other flow paths and time periods were quantified as follows:

- Pumping for Groundwater Transfer: measured data (propeller meters)
- Stormwater Runoff: IDC output for urban lands (see description above; represents runoff from urban areas that enters the SSJID Drainage System)

- Lateral Spillage (winter): estimated as zero
- IL Tailwater: IDC model output
- IL Runoff of Precip: IDC model output
- District Outflow (summer): Partially measured data
- Groundwater (GW) Transfer: measured data (propeller meters)
- Net seepage and groundwater interception (Seepage/GW Interception): calculated based on the wetted area, wetted duration, and an assumed seepage coefficient
- Drainage System Evaporation (DS Evap): Calculated from daily Manteca CIMIS station ET_0 multiplied by the open water surface area and an open water surface evaporation coefficient (1.1) (UCCE Extension Leaflet)

5.3.7 Flow Path Uncertainty

The results of the SSJID water budget are reported for each flow path with a high level of precision (nearest whole acre-foot) that implies a higher degree of accuracy in the values than is actually justified. To identify the level of uncertainty associated with each flow path, an estimated percent uncertainty has been defined for each measured or estimated flow path, approximately representing a 95 percent confidence interval. These uncertainty values are quantified based on the accuracy of measurement devices, typical values quantified in other water budgets, or professional judgment. Then, based on the relative magnitude of each flow path, the resulting uncertainty in each closure term can be estimated by assuming that errors in estimates are random, following the procedure described by Clemmens and Burt (1997). Errors in estimates for individual flow paths may cancel each other out to some degree, but the net error due to the collective uncertainty in the various estimated flow paths is ultimately expressed in the closure term.

Table 5-1 lists each flow path included in the water balance, indicating which accounting center(s) it belongs to, whether it is an inflow or an outflow, whether it was measured or estimated, the supporting data used to determine it, and the estimated uncertainty, expressed as a percent. As indicated, estimated uncertainties vary by flow path from 5 to 100 percent of the estimated value, with uncertainties generally being less for measured flow paths and greater for estimated flow paths. The estimated uncertainty of each closure term is also provided, calculated based on the concept of propagation of random errors as described above.

The general increase in flow path uncertainty as the water flows from the distribution system accounting centers to the Irrigated Lands accounting center is typical of agricultural water suppliers. Increased uncertainty for the Irrigated Lands accounting center results chiefly from estimates of tailwater and deep percolation flow paths as these flows are difficult and expensive to accurately measure. Despite appreciable uncertainty in some flow path quantities, the water balance provides useful insights into SSJID's water management.

Intentionally Left Blank

Table 5-1. Water Balance Flow Paths, Supporting Data, and Estimated Uncertainty

Accounting Center, Flow Path Direction	Flow Path	Database Data Source	Average Volume 2005-2024, af	Uncertainty	Uncertainty Source	
Main Supply Canal Above Woodward Reservoir	Inflows	Deliveries from Joint Supply Canal	Measured--Rated Section	221,090	6%	Dickinson, 1967; USBR, 2001
		Ordered Spillage	Measured--Rated Section	1,133	6%	Dickinson, 1967; USBR, 2001
		MSC Precip	Manteca CIMIS	18	30%	Clemmens, A.J. and C.M. Burt, 1997
	Outflows	Woodward Reservoir Inflows	Closure (MSC)	218,552	6%	Computed
		MSC Canal Seepage	NRCS soils data, published seepage rates by soil type, estimated wetted area, estimated wetted duration	459	50%	Typical of monthly calculation based on NRCS soils data and measured inflows
		MSC Evap	Estimate--surface area, Kc and ETo	76	30%	Clemmens, A.J. and C.M. Burt, 1997; Based on 20 percent estimate of Kc*ETo process plus 10 percent allowance for surface area estimate
		U3 Ranch Deliveries	One slide gate and one weir	3,153	100%	Computed based on estimated accuracy of measurement method used for spillage location.
Woodward Reservoir	Inflows	Woodward Reservoir Inflows	Closure (MSC)	218,552	6%	Computed
		Tributary Inflows	Tributary Area X Precip X Factor	3,946	50%	DE estimate
		Reservoir Precip	Estimate	1,346	30%	Clemmens, A.J. and C.M. Burt, 1997
	Outflows	Woodward Reservoir Releases	Measured--Rated Section	180,444	6%	Dickinson, 1967; USBR, 2001
		WTP Deliveries	KROHNE INFL meter - FIT-1320-1 & FIT-1320-2	18,501	5%	Manufacturer's accuracy (typical)
		Reservoir Seepage	NRCS soils data, published seepage rates by soil type, estimated wetted area	16,471	50%	Typical of monthly calculation based on NRCS soils data and measured inflows
		Reservoir Evap	Estimate--surface area, Kc and ETo	8,561	100%	Clemmens, A.J. and C.M. Burt, 1997; Based on 20 percent estimate of Kc*ETo process plus 10 percent allowance for surface area estimate.
Change in Reservoir Storage	Closure (WR)	-132.46	-16001%	Typical uncertainty of change in storage calculation.		
Main Supply Canal Below Woodward Reservoir and Main Distributory Canal	Inflows	Woodward Reservoir Releases	Measured--Rated Section	180,444	6%	Dickinson, 1967; USBR, 2001
		OID Spills to Main Canal	Measured	3,704	50%	USBR, 2001 (combined for all sites)
	Outflows	Lateral Deliveries	SonTek IQ meters in pipes	155,754	5%	Computed for 1% manufacturer's flow accuracy, and typical duration accuracy
		Direct Diversion from Main Canal	Recorded Deliveries in TruePoint	1,279	25%	DE estimate
		Ordered Spillage	Measured--Rated Section	1,133	6%	Dickinson, 1967; USBR, 2001
		Operational Spillage	Long crested weir	0	9%	Computed based on estimated accuracy of measurement method used for spillage location.
		MDC Canal Seepage	Closure (MDC)	25,464	53%	Computed
MDC Evap	Estimate--surface area, Kc and ETo	518	30%	Clemmens, A.J. and C.M. Burt, 1997; Based on 20 percent estimate of Kc*ETo process plus 10 percent allowance for surface area estimate.		
District Laterals	Inflows	Lateral Deliveries	SonTek IQ meters in pipes	155,754	5%	Computed for 1% manufacturer's flow accuracy, and typical duration accuracy
		District Pumping	Assumes measurement with some type of propeller meter.	4,582	20%	Idaho Department of Water Resources study
	Outflows	Farm Deliveries (to Irrigated Lands)	Closure (DL)	134,158	11%	Computed
		Surface Water Deliveries (to Urban Lands)	Recorded Deliveries in TruePoint	151	25%	DE estimate
		Lateral Spillage	Closure (DS)	20,270	59%	Computed
Lateral Seepage	Canal lining seepage coefficient, estimated wetted area, estimated wetted duration	5,053	50%	Typical of monthly calculation based on a		

Accounting Center, Flow Path Direction		Flow Path	Database Data Source	Average Volume 2005-2024, af	Uncertainty	Uncertainty Source		
						seepage coefficient and measured inflows		
		DL Evap	Estimate--surface area, Kc and ETo	703	30%	Clemmens, A.J. and C.M. Burt, 1997; Based on 20 percent estimate of Kc*ETo process plus 10 percent allowance for surface area estimate.		
Irrigated Lands	Inflows	Farm Deliveries	Closure (DL)	134,158	11%	Computed		
		Direct Diversion from Main Canal	Recorded Deliveries in TruePoint	1,279	25%	DE estimate		
		Private Pumping	Efficiency Estimate	62,276	50%	DE estimate (Typical uncertainty calculated from closure based on IDC results and measured surface water deliveries)		
		IL Precip	Manteca CIMIS	50,371	30%	Clemmens, A.J. and C.M. Burt, 1997		
	Outflows	IL ET _{aw}	Irrigated area/crops/Kc/ETo/monthly water balance	134,295	10%	CIMIS reference ET, estimated crop coefficients from METRIC analysis, cropped area by crop, root zone simulation model (IDC) to divide ET in applied water and precipitation components.		
		IL ET _{precip}	Irrigated area/crops/Kc/ETo/monthly water balance	26,516	10%	CIMIS reference ET, estimated crop coefficients from METRIC analysis, cropped area by crop, root zone simulation model (IDC) to divide ET in applied water and precipitation components.		
		IL Deep Percolation _{aw}	Closure (IL)	60,574	67%	Computed		
		IL Deep Percolation _{precip}	DE Root Zone Model	22,556	30%	Root zone simulation model (IDC).		
		IL Tailwater	Efficiency Estimate	2,844	50%	DE estimate		
		IL Runoff of Precip	Estimate	143	35%	Root zone simulation model, CIMIS precipitation data, and NRCS curve number method.		
		IL Change in Root Zone Storage of Precipitation	DE Root Zone Model	1,155	30%	Root zone simulation model (IDC).		
		Drainage System	Inflows	Lateral Spillage	Closure (DS)	20,270	59%	Computed
				Pumping for Groundwater Transfer	Measured	141	5%	DE estimate
Stormwater Runoff	Estimate			2,359	35%	Root zone simulation model, CIMIS precipitation data, and NRCS curve number method.		
IL Tailwater	Efficiency Estimate			2,844	50%	DE estimate		
IL Runoff of Precip	Estimate			143	35%	Root zone simulation model, CIMIS precipitation data, and NRCS curve number method.		
Outflows	District Outflow		Estimated / Measured	23,180	50%	USBR, 2001 (combined for all sites)		
	GW Transfer		Measured	282	5%	DE estimate		
	Seepage/GW Interception		Estimate; based on assumed seepage coefficient, estimated wetted area, estimated wetted duration	2,067	100%	Typical of monthly calculation based on seepage coefficient and measured inflows		
	DS Evap		Estimate--surface area, Kc and ETo	369	30%	Based on 20 percent estimate of Kc*ETo process plus 10 percent allowance for surface area estimate.		

5.4 HYDROLOGIC YEAR TYPES IN SSJID

Development of a multi-year water balance allows for evaluation of the varied impacts of surface water supply, precipitation, and other hydrologic variability on SSJID’s water management and use over time. Specifically, a multi-year water balance that includes both dry and wet years is essential to planning for conjunctive use of surface water and groundwater, an EWMP included in the CWC and discussed in Section 7.

The SSJID water budget presented in this section covers a 20-year period from 2005 through 2024. Each year is classified by hydrologic year type, as shown in Table 5-2 (“wet” or “dry”). Hydrologic year types are based on the DWR San Joaquin Valley Water Year Hydrologic Classification Index, with “wet” years defined as those classified as wet or above normal, and “dry” years defined as those classified as below normal, dry, or critically dry. Hydrologic year types are included in each water budget table throughout this section to support interpretation of water use within SSJID and evaluation of overall water balance trends over time. Between 2005 and 2024, eight years are classified as wet and twelve years as dry.

Between 2005-20124, the dry-year average precipitation was 9.8 inches, nearly four inches lower than the wet-year average precipitation of 14.1 inches. The atmospheric water demand (ET_o) is also typically higher in dry years, resulting in increased crop irrigation requirements and corresponding irrigation demands. Over the 2005-2024 period, the dry-year average ET_o was approximately 55.2 inches per year, versus 51.5 inches per year in wet years. These increased demands are typically coupled with reduced surface water supplies in dry years with partial surface water allocations.

As discussed previously, SSJID has a reliable source of surface water supply under its 1988 agreement with USBR which is based on inflows into New Melones Reservoir. However, reduced precipitation and increased atmospheric water demand (ET_o) in the SSJID service area typically occurs in years when precipitation is also reduced in the Stanislaus River watershed, limiting inflows into New Melones Reservoir. Consequently, between 2005-2024, SSJID did not receive its full entitlement in 2007-2008, in 2013-2016, and most recently in 2021.

Evaluating the SSJID water budget according to these “wet” and “dry” hydrologic year type classifications supports deeper understanding of the implications of reduced precipitation, increased ET_o , and partial allocations on SSJID’s water resources. This in turn, may support the identification and implementation of management actions to increase the reliability of surface water and groundwater supplies while maintaining or improving levels of service to the water users.

Table 5-2. SSJID Allotment, Precipitation, ET_o, and Hydrologic Year Type (2005-2024).

Year	Hydrologic Year Type	Irrigation Start	Irrigation End	Irrigation Season Length (Days)	Surface Water Allotment	Precipitation, in	ET _o , in
2005	Wet	3/13	10/22	223	Full	17.4	51.1
2006	Wet	3/21	10/21	214	Full	15.0	50.7
2007	Dry	3/11	10/17	220	Partial	6.3	55.9
2008	Dry	3/9	10/16	221	Partial	8.6	55.5
2009	Dry	3/11	10/20	223	Full	11.0	53.1
2010	Wet	3/15	10/24	223	Full	18.4	49.1
2011	Wet	3/13	10/29	230	Full	11.0	49.7
2012	Dry	3/11	10/19	222	Full	12.6	53.9
2013	Dry	3/8	10/19	225	Partial	4.6	56.9
2014	Dry	3/17	10/1	198	Partial	13.6	55.3
2015	Dry	3/8	10/10	216	Partial	6.6	54.3
2016	Dry	3/20	10/15	209	Partial	16.1	53.2
2017	Wet	3/19	10/21	216	Full	9.7	53.1
2018	Dry	2/25	10/20	237	Full	12.0	54.7
2019	Wet	3/17	10/26	223	Full	13.0	54.5
2020	Dry	3/4	10/15	225	Full	6.1	55.8
2021	Dry	3/7	10/9	216	Partial	10.2	56.5
2022	Dry	2/28	10/10	224	Full	9.3	57.7
2023	Wet	4/9	11/4	209	Full	15.7	51.8
2024	Wet	3/17	10/19	216	Full	11.8	51.8
2005-2024	Average					11.4	53.7
	Wet Year Average					14.0	51.5
	Dry Year Average					9.8	55.2
2020-2024	Average					10.6	54.7
	Maximum					15.7	57.7
	Minimum					6.1	51.8

5.5 WATER USES

Since 1909, SSJID has supplied irrigation water in southern San Joaquin County. With the completion of the Nick C. DeGroot Water Treatment Plant (WTP) at Woodward Reservoir in 2005, SSJID also provides treated drinking water to the Cities of Tracy, Manteca, and Lathrop. Between 2020-2024, SSJID supplied an average of 23,360 af of water to the (WTP) each year. In the future, the Cities are starting discussions on WTP upgrades through Phase 2 of the South

County Water Supply Program which includes building additional capacity and supplying drinking water to the City of Escalon. The City of Ripon has also shown interest in connecting to the WTP and receiving treated drinking water. SSJID currently supplies raw water to Ripon for non-potable uses.

The District co-owns three reservoirs with OID that are managed by the Tri-Dam Project and Tri-Dam Power Authority. These reservoirs are used for water supply, power generation, recreation, and water sports. The Authority also owns and operates a separate hydro-power generation facility known as Sand Bar. All of these reservoirs lie outside of SSJID’s service area. SSJID also owns the Frankenheimer and Woodward power generation facilities at the inlet and outtake of Woodward Reservoir, respectively. Turlock Irrigation District (TID) provided the financial capital for the installation of these sites in the early 1980s and operates and maintains the projects. Through the District’s water conservation efforts, SSJID’s water has been made available for environmental enhancement through water transfers and in-lieu groundwater recharge. These water uses are described in greater detail in the remainder of this section.

5.5.1 Agricultural

Agricultural irrigation is the dominant water use in SSJID (Figure 5-2). Between 2005 and 2024, the total crop water demand (evapotranspiration, ETc) for crops grown in SSJID averaged approximately 161,000 acre-feet (af) per year. Of this total, an average of 27,000 af is supplied by effective precipitation stored in the root zone, while approximately 134,000 af is supplied by applied irrigation.



Figure 5-2. Young Almond Orchard in SSJID

Table 5-3 summarizes the acreage of major crops and crop groups in SSJID. Over the 2005–2024 period, irrigated cropland averaged approximately 51,000 acres annually, with an additional 2,000 acres of fallow or idle land. Almonds are the dominant crop, occupying an average of 33,500 acres. Other permanent tree and vine crops, including fruit trees, grapes, and walnuts, account for an additional 7,200 acres on average. In total, permanent crops represent approximately 80 percent of the irrigated acreage in SSJID, with annual and semi-permanent crops comprising the remaining 20 percent.

Acreage planted to permanent crops ranged from approximately 38,000 to 43,000 acres over the 20-year period, as shown in Table 5-3 and Figure 5-3. These crops represent a relatively fixed and reliable demand for District water supplies.

Improved, locally derived crop coefficients were developed for the SSJID water balance to reflect actual crop water use conditions. Daily crop coefficients were derived from estimates of actual evapotranspiration (ET_a) using remotely sensed surface energy balance methods. Specifically, the

Improved, local crop coefficients were developed for the SSJID water balance that reflect actual, observed water use characteristics of crops in SSJID. Daily crop coefficients were derived from actual evapotranspiration (ET_a) estimates calculated using remotely sensed surface energy balance results from two recent years. The Mapping EvapoTranspiration at high Resolution with Internalized Calibration (METRIC) surface energy balance approach was used to calculate ET_a in SSJID. METRIC results account for the many factors that impact crop evapotranspiration (ET_c), including crop age, vegetation density, disease, salinity, deficit irrigation, and other stress factors.

Previous studies (e.g., Bastiaanssen et al., 2005; Allen et al., 2007, 2011; Thoreson et al., 2009) indicate that seasonal ET_a estimates derived using METRIC are typically within ±5 to 15 percent of actual evapotranspiration when performed by experienced analysts.

Average crop evapotranspiration rates (Table 5-4) were calculated using CIMIS reference evapotranspiration (ET_o) in combination with the locally derived crop coefficients. These ET_c values were then input into the Integrated Demand Calculator (IDC, Version 2015.0.0036; DWR, 2015), which partitions total ET_c into evapotranspiration of applied water (ET_{aw}) and evapotranspiration of precipitation (ET_{precip}).

The IDC model simulates daily soil water balance processes using precipitation, soil properties, and crop characteristics to estimate inflows and outflows within the root zone. This approach provides a consistent and reliable estimate of ET_c and its components, improving overall water budget accuracy.

Across all crops, average ET_c ranges from approximately 22.9 inches per year for grapes to approximately 38–39 inches per year for almonds, walnuts, and pasture. The average ET_c across all irrigated lands is approximately 36.7 inches per year. Almonds, the primary crop in SSJID, have an average ET_{aw} of approximately 32 inches per year. Overall, average ET_{aw} across all crops is approximately 31 inches, with the remaining 6 inches supplied by precipitation.

Over the 2005–2024 period, total annual ET_c averaged approximately 161,000 af, with approximately 134,000 af (83 percent) derived from applied irrigation and 27,000 af (17 percent) from precipitation. Additional applied water uses include salt leaching and frost protection. Due to the relatively low salinity of SSJID surface water, leaching requirements are minimal. Similarly, water used for frost protection is limited in volume and typically applied outside the primary irrigation season. These uses are described further in Section 5.10.

Table 5-3. SSJID Crop Acreages (2005-2024).

Year	Permanent			Annual	Semi-Permanent	Idle	Total
	Almonds	Others	Subtotal				
2005	31,771	8,074	39,845	6,210	5,944	1,903	53,901
2006	31,920	7,636	39,555	6,465	5,600	1,915	53,535
2007	31,747	7,374	39,121	6,390	5,440	1,943	52,893
2008	30,699	7,233	37,932	6,895	4,992	1,876	51,695
2009	31,854	7,018	38,872	6,737	4,762	1,759	52,131
2010	31,854	7,018	38,872	6,737	4,762	1,759	52,131
2011	31,854	7,018	38,872	6,737	4,762	1,759	52,131
2012	33,010	6,803	39,813	6,579	4,532	1,643	52,567
2013	32,673	6,936	39,608	6,579	4,559	1,669	52,416
2014	32,757	7,172	39,929	6,640	4,474	1,857	52,901
2015	33,252	7,214	40,466	6,499	4,374	1,850	53,189
2016	34,508	6,967	41,475	5,222	3,700	2,495	52,892
2017	34,730	7,304	42,034	5,313	3,621	2,221	53,189
2018	34,789	7,379	42,168	5,231	3,488	2,262	53,149
2019	34,892	7,372	42,264	5,201	3,665	2,201	53,331
2020	35,388	7,115	42,503	5,232	3,662	2,101	53,499
2021	34,787	7,203	41,990	5,516	3,510	1,751	52,766
2022	35,714	6,999	42,712	5,191	3,253	1,357	52,514
2023	35,714	6,999	42,712	5,191	3,253	1,357	52,514
2024	36,303	6,533	42,835	5,057	3,245	999	52,137
Average	33,511	7,168	40,679	5,981	4,280	1,834	52,774
Maximum	36,303	8,074	42,835	6,895	5,944	2,495	53,901
Minimum	30,699	6,533	37,932	5,057	3,245	999	51,695

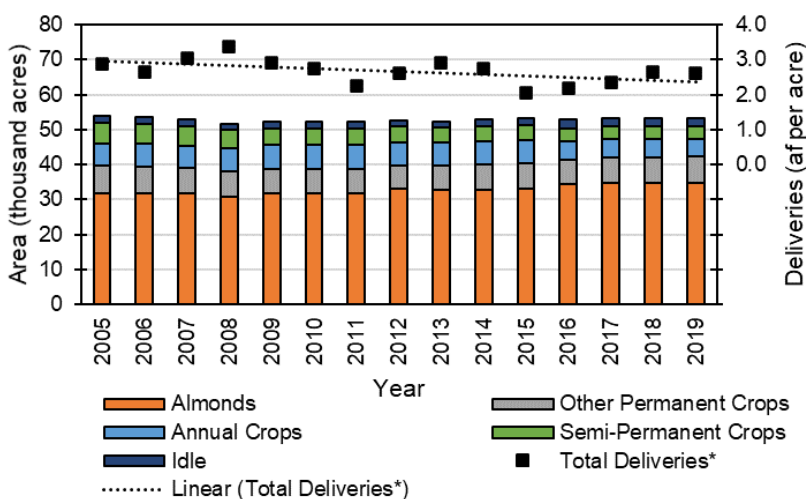

Figure 5-3. SSJID Cropping (2005-2019).

*Total deliveries include SSJID farm deliveries and direct deliveries from Main Canal.

Table 5-4. Average Acreages and Annual Evapotranspiration Rates for SSJID Crops (2005-2024).

Crop Group	Average Acres	Average Evapotranspiration (in/year)		
		ET _c	ET _{aw}	ET _{precip}
Alfalfa	1,178	36.9	30.2	6.7
Almonds ¹	33,947	38.7	32.3	6.4
Corn	4,831	33.1	27.3	5.7
Grapes	2,786	22.8	17.6	5.2
Open	1,834	27.1	22.7	4.4
Other Crops	2,050	35.5	30.8	4.8
Pasture	3,100	38.1	32.1	6.0
Peaches	1,148	36.8	30.7	6.1
Walnuts	1,898	38.4	31.9	6.5
Total	52,772	36.7	30.6	6.1

¹ The “Almonds” crop group includes comparatively small acreages of other miscellaneous orchard crops. ET for these other orchard crops was calculated using the almonds crop coefficients, as they are considered to have similar crop water requirements.

5.5.2 Environmental

The District is currently a member of the San Joaquin Tributaries Authority (SJTA) along with its partners, Modesto Irrigation District (MID), Turlock Irrigation District (TID), and the City and County of San Francisco. The SJTA is actively engaged in advancing collaborative, sustainable water management and flood control while providing dependable water supplies for agriculture, the environment, and the communities we serve.

Previously, the District had been a member of the San Joaquin River Group Authority along with Merced Irrigation District (Merced ID), TID, MID, Oakdale Irrigation District (OID), Friant Water Users Authority (FWUA), the San Joaquin River Exchange Contractors Water Authority (Exchange Contractors) and its member districts, and San Francisco. The San Joaquin River Agreement is a cooperative effort developed by urban, agricultural, environmental and governmental agencies to meet flow obligations at Vernalis on the San Joaquin River southeast of Tracy. Under the Agreement, the Vernalis Adaptive Management Plan (VAMP) was developed as an experimental adaptive management program designed to protect juvenile Chinook salmon during migration through the River while also evaluating the effects of flows on salmon survival. VAMP was initiated in 2000 and ended in 2011.

Under VAMP, SSJID and other member agencies were responsible for releasing supplemental water to provide spring (April – May) pulse flows to encourage outmigration of young fall run Chinook salmon. The required supplemental pulse flows varied from year to year depending on existing flow conditions in the River and previous year conditions. In certain years, SSJID’s VAMP obligation was made available to USBR at New Melones Reservoir to be used at the

Bureau’s discretion for authorized purposes. Typically, USBR released the additional water during other times of the year or carried it over in storage to the following year and then released it.

The objectives of these supplemental releases included various fish and wildlife benefits such as additional instream flows on the Stanislaus River during the months when fish are present, ramping of flow changes on the River following high flow periods, implementing pre-VAMP and post-VAMP ramping objectives during the spring flow period, water for fall attraction flows, temperature control in the lower Stanislaus River during the summer and fall periods, and/or storage in New Melones Reservoir for the purpose of using the additional water to augment flows in subsequent dry years.

The total volume of water provided by SSJID for pulse flows or to USBR for other environmental purposes on the Stanislaus and San Joaquin rivers from 2000 to 2010 is summarized in Table 5-5. As suggested by the table, the need for SSJID supplemental water to increase river flows is correlated to years with partial allotments due to reduced inflow into New Melones Reservoir. During the 2005 to 2011 period, the two years in which SSJID provided supplemental water were the partial allocation years of 2007 and 2008.

Table 5-5. Annual SSJID Supplemental Water under VAMP (2000-2010⁷)

Year	SSJID Supplemental Water (af)
2000	7,300
2001	7,365
2002	3,795
2003	5,039
2004	5,880
2005	0
2006	0
2007	2,185
2008	7,260
2009	0
2010	0
Average	3,529

OID and SSJID have made water available for pulse flows on the Stanislaus River following the end of VAMP which are listed as part of water transfer opportunities section below. OID and SSJID continue to make water available to the State Wate Project and CVP water contractors for both export and also to provide a benefit to fisheries. The Districts will continue discussions

⁷ Based on San Joaquin River Group Authority annual technical reports from 2000 through 2010.

with the USBR on opportunities to make water available for the benefit of both water users and the environment; .

5.5.3 Recreational

The District co-owns three reservoirs with OID that are managed by the Tri-Dam Project and Power Authority: the Beardsley Reservoir and Donnells Reservoir (Figure 5-4) above New Melones Reservoir, and Tulloch Reservoir below New Melones Reservoir. These reservoirs are used for water supply, power generation, recreation, and water sports. All three reservoirs lie outside of SSJID’s service area.

Woodward Reservoir is owned by SSJID, with the adjoining lands and water surface managed for recreational purposes by the Stanislaus County Parks and Recreation Department. The Woodward Regional Park offers established campsites and recreational activities including hunting, fishing, boating, and swimming.

Water stored in the reservoirs is not “used” for recreation, per se, as it is not consumed to support recreation activities. Rather, the storage of water in the reservoirs supports recreation activities.

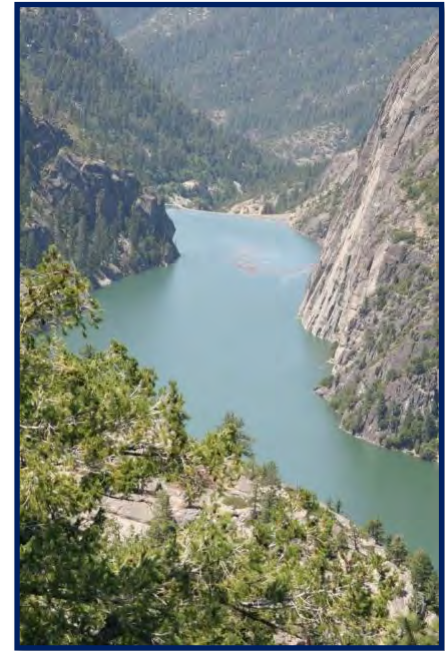

Figure 5-4. Donnells Reservoir

5.5.4 Municipal and Industrial

SSJID currently provides treated drinking water to several municipalities in San Joaquin County as part of the District’s existing pre-1914 surface water rights. The South County Water Supply Program (SCWSP) was developed through a collaborative effort between SSJID and the Cities of Manteca, Escalon, Lathrop, and Tracy to supplement municipal water supplies, particularly for cities historically reliant on groundwater. The participating cities financed the construction of the Nick C. DeGroot Water Treatment Plant (WTP), located just west of Woodward Reservoir Dam on Dodds Road.

Phase I of the project includes approximately 37 miles of transmission pipeline supplying the Cities of Manteca, Lathrop, and Tracy. The system includes four pump stations and three large storage tanks, which deliver water from the transmission system to municipal distribution systems and provide operational storage capacity. SSJID operates the WTP and serves as the wholesale water provider, while the participating cities act as retail water agencies under agreements extending through December 2049.

The SCWSP was designed to allow for phased expansion of treatment and delivery capacity. A future Phase II expansion is intended to increase treatment capacity at the WTP and expand service to additional participating agencies, including the City of Escalon. Escalon has an existing contractual allocation under the program but is not currently receiving treated water service.

The Phase II configuration includes an additional pump stations, treatment and storage facilities to support increased deliveries (P&P, 2011). The City of Ripon is not currently a participant in the SCWSP and instead purchases untreated surface water from SSJID for non-potable uses, although discussions regarding potential future participation have occurred. Contractual water supply allotments for participating cities under Phase I and Phase II are summarized in Table 5-6 (Water Supply Development Agreements between the Cities and SSJID).

Table 5-6. SCWSP Phase I and II Allotments by City (acre-feet)

Phase	City				Total
	Escalon	Lathrop	Manteca	Tracy	
Phase I Allotment	2,015	6,887	11,500	11,120	31,522
Phase II Allotment	2,799	10,671	18,500	11,120	43,090

Source: Water Supply Development Agreements between the Cities and SSJID

Raw water is diverted from Woodward Reservoir to the WTP, where it is treated using membrane filtration and chemical treatment processes to meet drinking water standards. Since becoming operational in 2005, the WTP has delivered treated surface water supplies to participating cities, with annual deliveries increasing over time. In recent years, deliveries have exceeded 24,000 acre-feet annually (in 2020), and the facility has operated at or near its existing capacity during peak demand periods (SSJID, 2022; P&P, 2011).

The opportunity to provide supplemental municipal water supplies was made possible through SSJID’s long-term investments in water conservation and system efficiency improvements, which reduced operational losses and increased available supplies. These efforts have improved the reliability and flexibility of both agricultural and municipal water deliveries. The SCWSP also supports regional groundwater management objectives and provides a reliable source of high-quality drinking water to local communities.

Table 5-7. Annual Deliveries to Nick C. DeGroot WTP for Urban Water Supply (2005-2024).

Year	Year Type	WTP Deliveries (af)
2005	Wet	1,326
2006	Wet	11,707
2007	Dry	16,794
2008	Dry	16,479
2009	Dry	19,376
2010	Wet	16,931
2011	Wet	17,927
2012	Dry	18,426
2013	Dry	20,148
2014	Dry	18,840
2015	Dry	15,406
2016	Dry	17,001
2017	Wet	20,124
2018	Dry	21,046
2019	Wet	21,690
2020	Dry	23,984
2021	Dry	24,043
2022	Dry	23,863
2023	Wet	21,196
2024	Wet	23,715
2005-2019	Average	18,501
	Wet Year Average	16,827
	Dry Year Average	19,617
2020-2024	Average	23,360
	Maximum	24,043
	Minimum	21,196

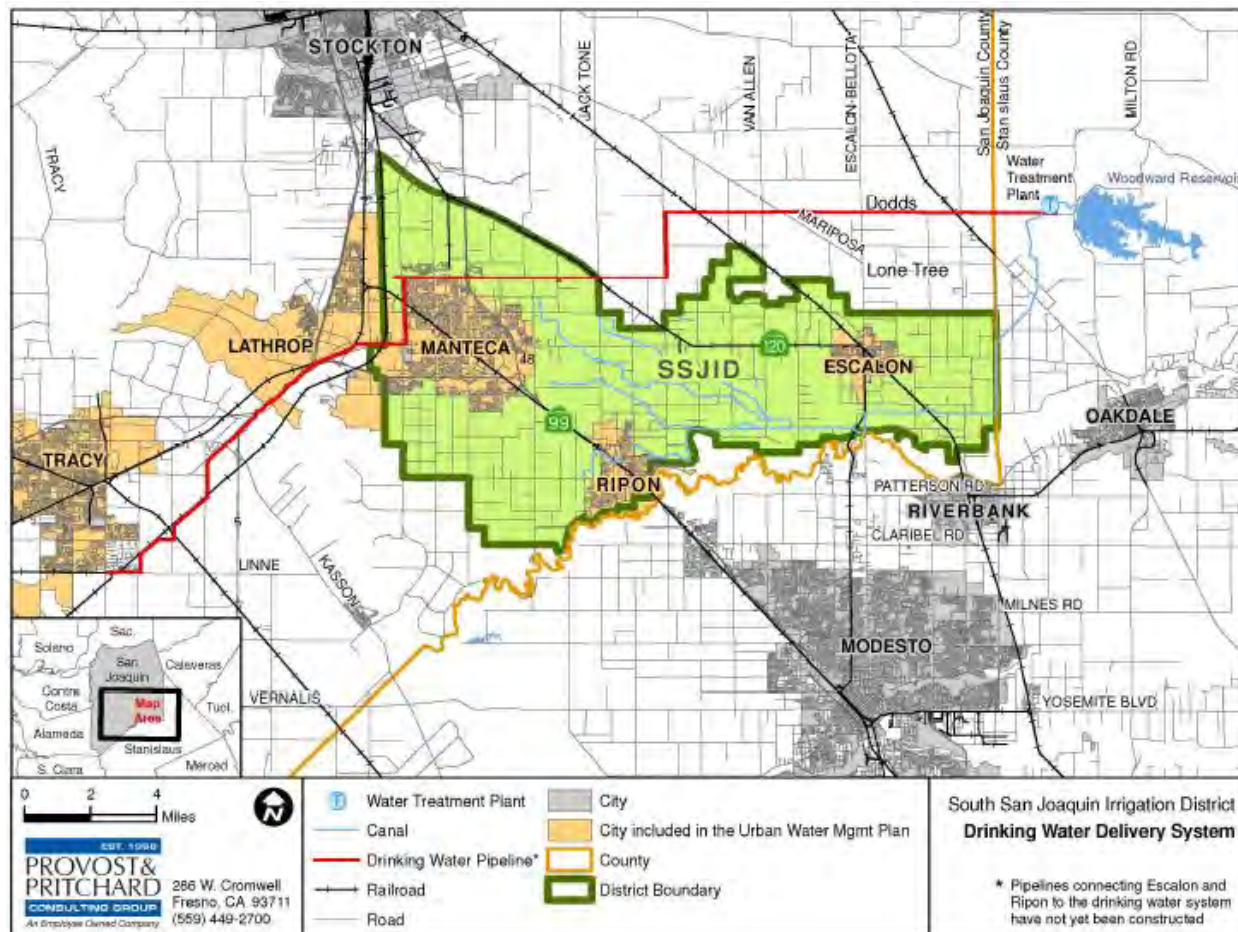

Figure 5-5. SCWSP Phase I Water System

To offset WTP power demands, SSJID constructed a seven-acre solar array utilizing thin-film solar modules mounted on tracking frames. Construction was completed in two phases. Phase I included approximately 7,000 175-watt crystalline modules with a maximum production capacity of 1.2 megawatts and was placed into service on May 15, 2008, with formal dedication as the Robert O. Schulz Solar Farm on July 18, 2008. Phase II was completed in March 2009 and added approximately 6,000 72.5-watt thin-film modules, increasing total production capacity to approximately 1.4 megawatts. In 2025, the District initiated a \$4.5 Million re-powering project of the Solar Farm bringing increasing power production levels to offset a higher proportion of WTP power needs.

The solar facility supplies a substantial portion of the power required for WTP operations, reducing energy costs and helping maintain lower water rates for participating agencies. Cost savings associated with the facility have historically been passed on to participating cities through reduced water rates. Additional information regarding Robert O. Schulz Solar Farm is available on the District’s website (SSJID, 2026): <https://www.ssjid.com/district-services/electric-services/>.

5.5.5 Groundwater Recharge

Groundwater recharge that occurs within SSJID consists of seepage from SSJID canals and reservoirs and deep percolation of precipitation and applied irrigation water. Distributed recharge from the SSJID service area provides substantial recharge to support groundwater levels in the Eastern San Joaquin Subbasin, which underlies SSJID and surrounding areas (see Section 4.3 for more information on the Eastern San Joaquin Subbasin). Inflows to the groundwater system and pumping volumes for the 2005 to 2024 period are shown in Figure 5-6, along with the net annual volume of groundwater recharge.

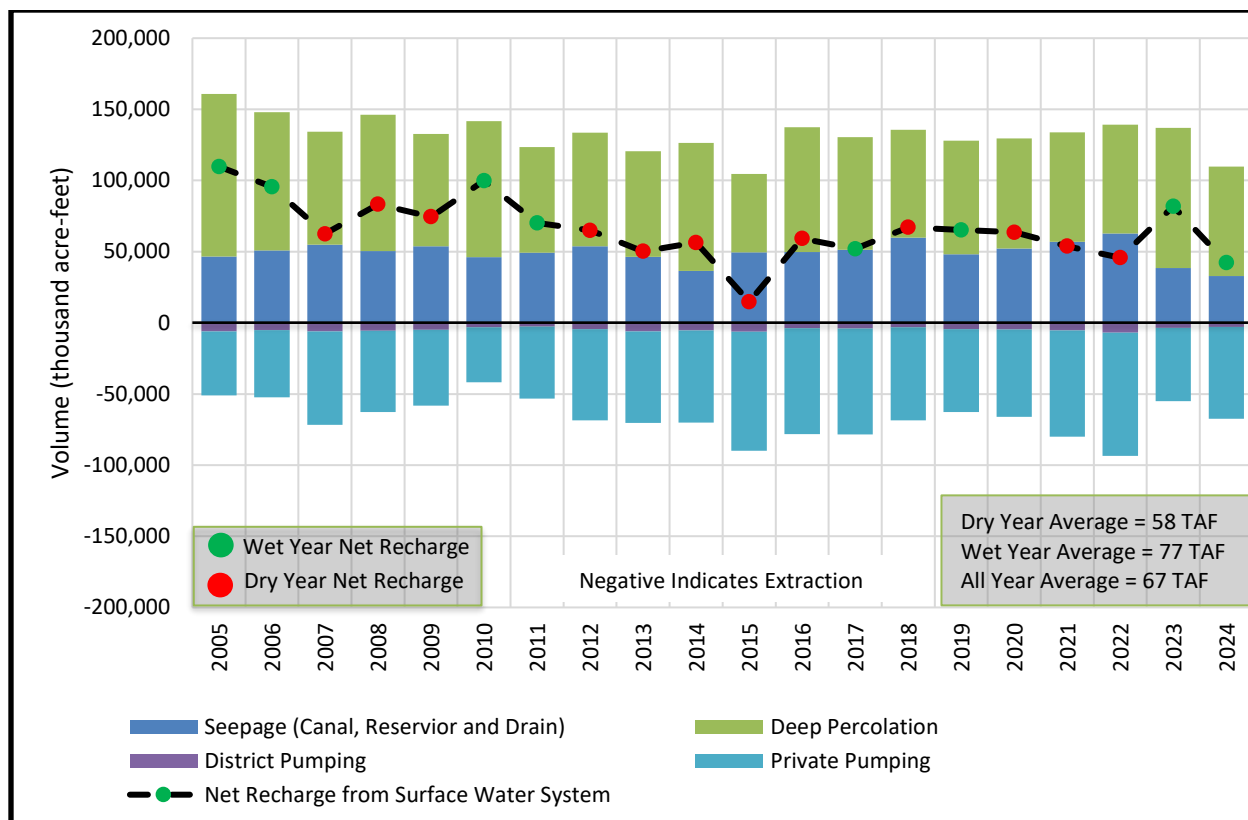

Figure 5-6. Groundwater System Inflows, Outflows, and Net Recharge (2005-2024)

Total seepage and deep percolation volumes for 2005 through 2024 are summarized in Table 5-8, including total recharge expressed both as volume and as a depth of water relative to cropped acreage. Over this period, total recharge ranged from approximately 131,000 acre-feet in average dry years to 135,000 acre-feet in average wet years, equivalent to approximately 2.5 acre-feet per cropped acre annually. On average, approximately 37 percent of recharge is derived from seepage and 63 percent from deep percolation,

Table 5-8. SSJID Total Groundwater Recharge (2005-2024)

Year	Surface Water Allotment	Hydrologic Year Type	Canal and Reservoir Seepage (af)	Drain Seepage (af)	Deep Percolation (af)	Total Recharge	
						(af)	(af/ac)
2005	Full	Wet	44,351	2,132	114,249	160,732	3.0
2006	Full	Wet	48,779	2,141	97,091	148,011	2.8
2007	Partial	Dry	52,841	2,120	79,245	134,205	2.5
2008	Partial	Dry	48,304	2,094	95,675	146,073	2.8
2009	Full	Dry	51,704	2,104	78,903	132,710	2.5
2010	Full	Wet	43,935	2,157	95,591	141,683	2.7
2011	Full	Wet	47,266	2,018	74,255	123,539	2.4
2012	Full	Dry	51,501	2,163	79,833	133,497	2.5
2013	Partial	Dry	44,508	1,945	74,103	120,556	2.3
2014	Partial	Dry	34,488	2,070	89,926	126,484	2.4
2015	Partial	Dry	47,505	1,990	55,181	104,676	2.0
2016	Partial	Dry	47,701	2,100	87,510	137,311	2.6
2017	Full	Wet	49,428	1,869	79,128	130,425	2.5
2018	Full	Dry	57,756	2,157	75,619	135,532	2.6
2019	Full	Wet	46,013	2,083	79,939	128,034	2.4
2020	Full	Dry	50,114	1,977	77,562	129,653	2.4
2021	Partial	Dry	54,853	2,085	76,952	133,889	2.5
2022	Full	Dry	60,853	1,818	76,553	139,224	2.7
2023	Full	Wet	36,238	2,157	98,579	136,974	2.6
2024	Full	Wet	30,783	2,163	76,717	109,664	2.1
2005-2024	Average		47,446	2,067	83,130	132,644	2.5
	Wet Year Average		43,349	2,090	89,444	134,883	2.5
	Dry Year Average		50,177	2,052	78,922	131,151	2.5
2020-2024	Average		46,568	2,040	81,273	129,881	2.5
	Maximum		60,853	2,163	98,579	139,224	2.7
	Minimum		30,783	1,818	76,553	109,664	2.1

Net recharge from the surface water system is used to quantify the contribution of District operations to overall groundwater conditions. Net recharge is calculated as the difference between total recharge and groundwater pumping. Annual net recharge estimates for the SSJID irrigated service area are presented in Table 5-9.

Table 5-9. SSJID Net Groundwater Recharge (2005-2024)

Year	Surface Water Allotment	Hydrologic Year Type	Total Recharge (af)	Groundwater Pumping (af)	Net Recharge	
					(af)	(af/ac)
2005	Full	Wet	160,732	50,936	109,796	2.0
2006	Full	Wet	148,011	52,389	95,622	1.8
2007	Partial	Dry	134,205	71,729	62,477	1.2
2008	Partial	Dry	146,073	62,761	83,312	1.6
2009	Full	Dry	132,710	58,170	74,540	1.4
2010	Full	Wet	141,683	41,804	99,880	1.9
2011	Full	Wet	123,539	53,304	70,235	1.3
2012	Full	Dry	133,497	68,593	64,904	1.2
2013	Partial	Dry	120,556	70,332	50,224	1.0
2014	Partial	Dry	126,484	70,080	56,405	1.1
2015	Partial	Dry	104,676	89,884	14,792	0.3
2016	Partial	Dry	137,311	78,141	59,170	1.1
2017	Full	Wet	130,425	78,537	51,889	1.0
2018	Full	Dry	135,532	68,484	67,048	1.3
2019	Full	Wet	128,034	62,771	65,263	1.2
2020	Full	Dry	129,653	66,044	63,609	1.2
2021	Partial	Dry	133,889	80,046	53,843	1.0
2022	Full	Dry	139,224	93,437	45,787	0.9
2023	Full	Wet	136,974	55,087	81,888	1.6
2024	Full	Wet	109,664	67,449	42,215	0.8
2005-2024	Average		132,644	66,999	65,645	1.2
	Wet Year Average		134,883	57,784	77,098	1.5
	Dry Year Average		131,151	73,142	58,009	1.1
2020-2024	Average		129,881	72,412	57,468	1.1
	Maximum		139,224	93,437	81,888	1.6
	Minimum		109,664	55,087	42,215	0.8

Between 2005 and 2024, total groundwater recharge averaged approximately 133,000 acre-feet per year, while combined District and private groundwater pumping averaged approximately 67,000 acre-feet per year. As a result, average net recharge to the groundwater system was approximately 66,000 acre-feet per year, or about 1.2 acre-feet per acre across the District’s cropped area. Net groundwater recharge is generally higher during wet years with full surface water allocations.

During the more recent period from 2020 through 2024, average net recharge decreased slightly to approximately 1.1 acre-feet per acre. This trend reflects changes in land and water use

practices, including an increase in permanent crops and micro irrigation systems, as well as the effects of the 2020–2021 drought, which reduced deep percolation and increased reliance on groundwater pumping.

5.5.6 Transfers and Exchanges

Voluntary transfers of water provide a source of funding for improvements to the SSJID distribution system. SSJID has participated in several water transfers in the past, and continues to seek opportunities for mutually beneficial transfer agreements with water users outside of the District. Parties to whom SSJID has transferred water include Stockton-East Water District (SEWD), VAMP, USBR, Central San Joaquin Water Conservation District (CSJWCD), Department of Water Resources, Banta Carbona Irrigation District (BCID), City of Mountain House (MH), San Luis-Delta Mendota Water Agency (SLDMWA), and South Delta Water Agency (SDWA).

In 1997, SSJID entered a 10-year contract with SEWD to provide a maximum of 15,000 acre-feet (adjusted based on annual inflows to New Melones) of surface water annually primarily for municipal and industrial use by the City of Stockton and the Lincoln Village and Colonial Heights Maintenance Districts. Deliveries commenced in 2000 and ended in 2010. SSJID transferred an additional 10,000 af to SEWD in 2016.

As described previously in Section 5.2.2, the VAMP and USBR transfers were primarily made for environmental uses, such as to encourage outmigration of fall run Chinook salmon smolt (Figure 5-7). In addition to environmental uses, transfers to USBR are integrated into the Central Valley Project (CVP) operations, enabling USBR to meet contractual water supply obligations more reliably and to comply with Delta outflow and water quality requirements.



Figure 5-7. Chinook Salmon Smolt

In 2015, as a humanitarian response to unprecedented drought conditions, 1,007 af of additional groundwater was pumped and transferred to the Mountain House Community Services District (incorporated as City of Mountain House in 2024) in southwestern San Joaquin County. Mountain House came to the District again in 2022 after the State Water Resources Control Board (State Water Board) issued a curtailment order which affected their primary source of water. Also in response to the drought in 2022, the District, in partnership with OID, transferred water to SEWD primarily to serve the drinking water needs of the City of Stockton Metropolitan area. In 2023, the District and OID antecedent a 10-year partnership with SEWD to provide

municipal and agricultural water for drought times and as a means to reduce conditions of groundwater overdraft.

The District has also made water available to the SDWA when certain growers who have more junior appropriative rights are curtailed by the State Water Board due to Term 91 restrictions. In 2023, the District in partnership with OID piloted a small water transfer with BCID. From 1997 to 2024, SSJID transferred a total of 464,721 af (Table 5-10).

Table 5-10. SSJID Water Transfers (1997-2024)

Year	Transfer Recipient								Total
	SEWD	VAMP	CSJWCD	USBR	SLDMWA	SDWA	MH	BCID	
1997	0	0	0	40,000	0	0	0		40,000
1998	0	0	0	25,000	0	0	0		25,000
1999	0	0	0	25,000	0	0	0		25,000
2000	15,000	7,300	0	0	0	0	0		22,300
2001	23,750	7,365	0	0	0	0	0		31,115
2002	15,000	3,795	20,000	0	0	0	0		38,795
2003	15,000	5,039	15,000	0	0	0	0		35,039
2004	15,147	5,880	10,000	0	0	0	0		31,027
2005	15,117	0	0	0	0	0	0		15,117
2006	15,298	0	0	0	0	0	0		15,298
2007	15,820	2,185	0	10,000	0	0	0		28,005
2008	18,200	7,260	1,600	0	0	0	0		27,060
2009	20,000	0	0	0	25,000	0	0		45,000
2010	4,089	0	0	0	0	0	0		4,089
2011	0	0	0	0	0	130	0		130
2012	0	0	0	0	0	150	0		150
2013	0	0	0	0	40,000	310	0		40,310
2014	0	0	0	0	0	0	0		0
2015	0	0	0	0	0	0	1,007		1,800
2016	10,000	0	0	16,000	0	238	0		26,238
2017	0	0	0	0	0	200	0		200
2018	0	0	0	0	0	150	0		150
2019	1,000	0	0	0	0	0	0		1,000
2020	0	0	0	0	0	0	0		0
2021	1,570	0	0	0	0	366	0		1,936
2022	6,912	0	0	0	0	805	1,800		9,517
2023	0	0	0	0	0	0	0	75	75
2024	0	0	0	0	0	370	0		370
Totals	191,903	38,824	46,600	116,000	65,000	2,719	2,807	75	464,721

5.5.7 Other Water Uses

Other incidental uses of water within SSJID may include watering of roads for dust abatement, agricultural spraying, and stock watering by SSJID water users. The volume of water used for such purposes is small relative to other uses and has not been quantified as part of this AWMP.

5.6 DRAINAGE

5.6.1 SSJID Boundary Outflows

As previously discussed, SSJID completed a systematic evaluation and ranking of boundary flow measurement sites through development of the SSJID Flow Measurement Plan. The purpose of this effort was to identify and prioritize improvements at drainage outflow locations, including phased upgrades to boundary measurement sites, assessment of delivery measurement accuracy, and evaluation of alternative measurement technologies.

Since that time, SSJID has expanded and enhanced its flow measurement and monitoring network, including installation of improved flow measurement devices and remote monitoring equipment at boundary outflow locations. Measurement infrastructure has also been expanded to include additional outflow sites and operational spill locations, including the use of advanced technologies such as SonTek Pipe IQ devices to improve measurement of spill flows.

Despite these improvements, variability in site conditions and measurement limitations at certain locations have continued to affect data reliability. As described in Section 3.4.3, SSJID completed a Drain Outflow Improvement Study to further evaluate measurement accuracy, identify data gaps, and develop a prioritized, phased approach for improving measurement reliability across the system.

Enhanced monitoring of drainage flows has improved the District's ability to evaluate opportunities to reduce, recover, and reuse boundary outflows within SSJID, thereby increasing the effective availability of surface water supplies. Continued implementation of measurement improvements is expected to further support water balance accuracy and operational decision-making.

Estimated total boundary outflows from SSJID for the period 2005 through 2024 are summarized in Table 5-11. Total boundary outflows ranged from approximately 12,000 acre-feet in 2021 to approximately 35,000 acre-feet in 2024. Elevated outflows in certain years reflect operational conditions, including system conveyance of flood releases, such as those requested by the USBR in 2011.

Annual boundary outflows vary between wet and dry hydrologic conditions, averaging approximately 28,000 acre-feet in wet years and 20,000 acre-feet in dry years. Differences in flow pathways and system operations between hydrologic conditions are summarized qualitatively in Table 5-12.

Table 5-11. Estimated SSJID Boundary Outflows (2005-2024).

Year	Surface Water Allotment	Hydrologic Year Type	District Outflow (af, from Drainage System)
2005	Full	Wet	27,058
2006	Full	Wet	24,848
2007	Partial	Dry	26,242
2008	Partial	Dry	24,847
2009	Full	Dry	22,467
2010	Full	Wet	27,998
2011	Full	Wet	35,118
2012	Full	Dry	30,927
2013	Partial	Dry	26,945
2014	Partial	Dry	17,581
2015	Partial	Dry	13,926
2016	Partial	Dry	19,159
2017	Full	Wet	17,123
2018	Full	Dry	13,119
2019	Full	Wet	15,942
2020	Full	Dry	12,790
2021	Partial	Dry	11,635
2022	Full	Dry	23,967
2023	Full	Wet	31,484
2024	Full	Wet	40,431
Wet Year Average			27,500
Dry Year Average			20,300
Overall Average			23,180
Year	Surface Water Allotment	Hydrologic Year Type	District Outflow (af, from Drainage System)
2005	Full	Wet	27,058
2006	Full	Wet	24,848
2007	Partial	Dry	26,242
2008	Partial	Dry	24,847
2009	Full	Dry	22,467
2010	Full	Wet	27,998
2011	Full	Wet	35,118
2012	Full	Dry	30,927
2013	Partial	Dry	26,945
2014	Partial	Dry	17,581
2015	Partial	Dry	13,926
2016	Partial	Dry	19,159
2017	Full	Wet	17,123
2018	Full	Dry	13,119

**2025 SSJID
 AGRICULTURAL WATER
 MANAGEMENT PLAN**

**WATER
 BALANCE**

2019	Full	Wet	15,942
2020	Full	Dry	12,790
2021	Partial	Dry	11,635
2022	Full	Dry	23,967
2023	Full	Wet	31,484
2024	Full	Wet	40,431
Wet Year Average			27,500
Dry Year Average			20,300
Overall Average			23,180

Table 5-12. General Effects of Hydrologic Year Type on SSJID Drainage System Inflows

Drainage System Flow Path	Wet Year Effect	Dry Year Effect	Notes
Lateral Spillage (Inflow)	More	Less	Operational spillage is related to hydrologic year type based on currently available data. Spill in dry years is reduced due to more careful operation of the distribution system.
Tributary Inflows	More	Less	Greater precipitation tends to occur during the irrigation season of wet years, resulting in increased tributary inflows.
Farm Tailwater (Inflow)	Little or No Change	Little or No Change	Tailwater production is limited in SSJID due to the predominance of level-basin irrigation and ongoing conversion to pressurized irrigation.
Runoff of Precipitation and Direct Precipitation (Inflow)	More	Less	Greater precipitation tends to occur during the irrigation season of wet years, resulting in increased runoff or precipitation and direct precipitation in the drains.

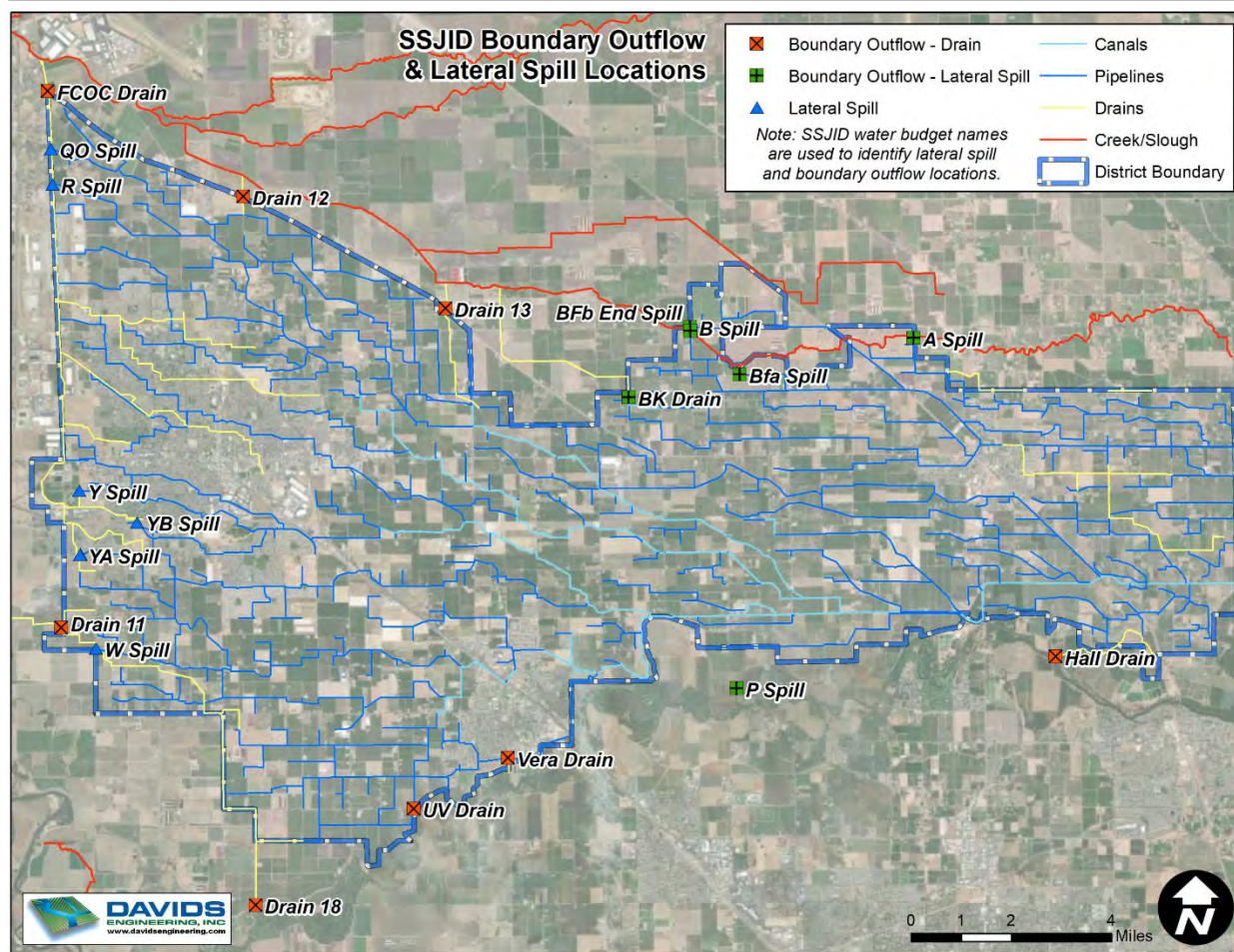

Figure 5-8. SSJID Boundary Outflow and Lateral Spill Locations.

5.7 WATER ACCOUNTING (SUMMARY OF WATER BALANCE RESULTS)

The SSJID water balance structure was shown previously in Figure 5-1. The water balance was prepared for six accounting centers: (1) Main Supply Canal above Woodward Reservoir; (2) Woodward Reservoir; (3) Main Supply Canal below Woodward Reservoir and the Main Distribution Canal; (4) District Laterals (5) Irrigated Lands; and (6) Drainage System. Additionally, the water balance can be summarized for the SSJID service area as a whole (“Water Balance Boundary,” shown in Figure 5-1). An accounting center representing the groundwater system is also included in Figure 5-1 to account for exchanges between the vadose zone and the aquifers underlying SSJID; however, a complete balance for the underlying aquifer is not calculated because not all subsurface groundwater inflows and outflows have been estimated as part of this AWMP. Tabulated water balance results for each accounting center are provided in Tables 5-13 through 5-18.

The water balance results presented in this AWMP section are provided on an annual time step. Underlying the annual time step is a more detailed water balance in which all flow paths are

determined on a monthly time step. Water year summaries of the complete SSJID water balance are included in Appendix F.

5.7.1 Main Supply Canal Above Woodward Reservoir

Table 5-13 presents the annual water balance for the Main Supply Canal Above Woodward Reservoir accounting center.

Over the 2005-2024 period, the Main Supply Canal received an average inflow of 221,000 af per year from Goodwin Dam via the Joint Supply Canal. When reservoir storage is sufficient, deliveries from the Joint Supply Canal are typically greater in dry years to support higher demand for deliveries. In dry years, less precipitation is available to support crop water demands and evaporative demands tend to be greater. As a result, additional irrigation deliveries are needed to maintain crop production.

Water diverted at Goodwin is either delivered to the U3 Ranch, lost as seepage or evaporation in the upper MSC, or stored in Woodward Reservoir. U3 Ranch deliveries are relatively steady, averaging 3,100 af per year between 2005-2024. Canal seepage and evaporation in the MSC is on the order of 460 af and 80 af per year, respectively.

In certain years particularly wet years, ordered spillage is released at Goodwin Dam. Ordered spillage includes water routed through the distribution system to spill points as part of water transfers and deliveries for environmental enhancement in downstream waterways.

5.7.2 Woodward Reservoir

Table 5-14 presents the annual water balance for the Woodward Reservoir accounting center.

Woodward Reservoir receives the majority of inflows from the Main Supply Canal. Other inflows include precipitation and tributary inflows, which average approximately 1,400 af and 4,000 af per year, respectively.

Much of the water entering Woodward Reservoir is stored and released to the District's distribution system where is delivered to irrigation customers and meet other downstream demands. Woodward Reservoir releases are steady in most years, except during the end of the 2012-2016 drought. Average releases total 180,500 af per year between 2005-2024, with similar averages in wet and dry years.

Some of the water is also delivered to the Nick C. DeGroot Water Treatment Plant (WTP), where it is treated and used to supply municipal water demands. Deliveries to the WTP averaged 18,500 af per year from 2005-2024.

Other outflows from the Woodward Reservoir include seepage to the groundwater system and evaporation losses. Reservoir seepage contributes over 16,000 af per year, on average, to

recharge of the Eastern San Joaquin Groundwater Subbasin. Evaporation losses total approximately 8,500 af per year.

Changes in reservoir storage over the 2005-2024 period ranged from plus or minus 16,000 af over the calendar year. Over time, the average change in storage is about 0 af as expected. Changes in storage in Woodward Reservoir between wet and dry years are similar, as the reservoir is generally operated to remain near capacity to maximize the available water supply should a failure occur in the Main Supply Canal. Maintaining the reservoir near capacity also supports local recreation opportunities. In extremely dry years, like 2015, the reservoir is operated at a lower elevation to reduce seepage. This drought response action is described in the Drought Management Plan (Appendix D).

5.7.3 Main Supply Canal below Woodward Reservoir and Main Distributory Canal

Table 5-15 presents the annual water balance for the Main Supply Canal below Woodward Reservoir and Main Distributory Canal accounting center.

The majority of inflows to the Main Supply Canal and Main Distributory Canal below Woodward Reservoir come directly from the reservoir. As described above, Woodward Reservoir releases are steady in most years except during the 2012-2016 drought. Over the 2005-2024 water balance period, Woodward Reservoir releases averaged approximately 180,500 af per year, with a maximum release of 213,000 af in 2008. On average, releases slightly increase in dry years in response to greater irrigation demand and a slightly longer average irrigation season length. However, releases decreased significantly during 2014-2016, dropping to 144,000 af in 2015 as the District restricted irrigation to 36 inches per acre in response to the drought. Water released from Woodward Reservoir is complemented by spillage from OID into the MSC. These inflows averaged approximately 3,700 af per year between 2005-2024.

Deliveries from the MDC include lateral deliveries, direct deliveries to irrigated lands from the MDC, and outflow of ordered spillage. Lateral deliveries are used to supply irrigation deliveries throughout SSJID's service area, ranging from 117,000 af to 189,000 af per year between 2005-2024. A comparatively small volume of water is delivered directly to irrigate lands from the MDC, totaling 1,300 af per year on average. Ordered spillage ranged from a low of zero af in several dry years to a high of 10,400 af in 2006. The majority of ordered spillage occurs in wet years.

Losses from the MSC below Woodward and the MDC include canal seepage, evaporation, and operational spillage. Seepage and evaporation are fairly constant from year to year, depending mostly on the irrigation season length. Seepage averaged 25,000 af per year between 2005-2024, while evaporation averaged 500 af per year. Unintentional operational spillage is essentially zero due to complete automation of the MSC below Woodward and the MDC.

5.7.4 District Laterals

Table 5-16 presents the annual water balance for the District Laterals accounting center.

The District laterals are the network through which the majority of irrigation deliveries are made. Water supplies for irrigation include lateral deliveries from the MDC and groundwater pumping provided by District-owned wells. Over the 2005-2024 period, lateral deliveries averaged 156,000 af per year, and ranged from 117,000 af in 2015 to 189,000 af in 2008. District pumping ranged from 2,600 to 6,100 af, averaging 4,600 af.

Farm deliveries from District laterals totaled 134,000 af per year, on average, between 2005-2024. Farm deliveries are generally higher in dry years, as irrigation demand increases and soil moisture from precipitation is diminished. During 2015, at the height of the 2012-2016 drought, farm deliveries dropped to 105,000 af as SSJID restricted available irrigation supplies to just 36 inches per acre.

Other outflows from the District laterals include spillage, seepage, and evaporation. Lateral spillage is generally slightly higher in wet years, averaging 24,000 af versus 17,500 af in dry years. Lateral seepage supplies approximately 5,000 af per year to the groundwater system. Evaporation losses total only about 700 af, as the majority of the District lateral system consists of pipelines.

5.7.5 Irrigated Lands

Water supplies for irrigation include farm deliveries from laterals, direct deliveries from the MDC, and private groundwater pumping. Over the 2005-2024 water balance period, farm deliveries averaged 134,000 af per year, direct deliveries from the MDC averaged approximately 1,300 af per year, and private pumping averaged 62,000 af per year. Table 5-17 presents the annual water balance for the Irrigated Lands accounting center.

Farm deliveries and private pumping are greater in dry years due to increased crop water requirements resulting from a longer irrigation season, less storage of precipitation in the root zone, and increased atmospheric water demand (ET_o). When farm deliveries decreased in 2015 as the District restricted irrigation supplies, private pumping increased further to meet irrigation demand.

The irrigation supply is consumed by crops as evapotranspiration, or lost as deep percolation or tailwater. Between 2005-2024, crop evapotranspiration of applied irrigation water on irrigated lands ($IL ET_{aw}$) ranged from 112,000 af to 151,000 af per year. As discussed previously, crop ET_{aw} is greater in dry years due to increased crop water requirements resulting from a longer irrigation season, less storage of precipitation in the root zone, and increased atmospheric water demand (ET_o). Deep percolation of applied water ($IL Deep Percolation_{aw}$) ranged from 45,000 af

to 78,000 af per year, with an overall average of 61,000 af. This water recharges the groundwater system and supports local and regional groundwater sustainability.

The objective of irrigation is to meet crop consumptive demand (ET_{aw}), along with any other agronomic on-farm water needs. Comparing ET_{aw} to total applied irrigation water, a Crop Consumptive Use Fraction (CCUF) may be calculated to provide an indicator of on-farm irrigation performance. The CCUF is calculated on an annual basis by dividing total ET_{aw} by total applied irrigation water (combined farm deliveries, direct diversion from Main Canal, and private pumping). In SSJID, the CCUF ranged from 63 percent to 75 percent from 2005-2024 with an average of 68 percent. The CCUF is often similar in wet and dry years due to SSJID's reliable surface water supply.

5.7.6 Drainage System

SSJID's drainage canals collect lateral spillage, tailwater and precipitation runoff from irrigated lands (IL tailwater and IL Runoff of Precip), and stormwater from the District service area, and drains this water to District outflow sites. In 2015 and 2022, the drainage system was also used to convey groundwater that was pumped and delivered to the Mountain House Community Services District as a humanitarian water transfer due to unprecedented drought conditions. Table 5-18 presents the annual water balance for the Drainage System accounting center.

In total, an average of 23,000 af of water drains from District outflow sites each year, ranging from an average of 27,500 af in wet years to 20,000 af in dry years. Seepage from the drainage system provides approximately 2,000 af of recharge to the groundwater system each year, while the remaining 400 af evaporates.

Intentionally Left Blank

Table 5-13. Annual Water Balance for Main Supply Canal Above Woodward Reservoir.

Year	Hydrologic Year Type	Irrigation Seasons Number of Days ¹	Inflow (af)			Outflow (af)				Performance Indicators
			Deliveries from Joint Supply Canal	Ordered Spillage	MSC Precip	Woodward Reservoir Inflows	U3 Ranch Deliveries ²	MSC Canal Seepage	MSC Evap	MSC Efficiency ³
2005	Wet	224	204,501	260	27	200,316	3,949	449	74	99.7%
2006	Wet	215	222,390	10,358	23	228,276	3,971	453	72	99.8%
2007	Dry	221	249,569	1,081	10	245,708	4,407	466	80	99.8%
2008	Dry	222	252,483	277	13	247,753	4,473	468	80	99.8%
2009	Dry	224	244,059	280	17	239,510	4,320	449	77	99.8%
2010	Wet	224	223,202	260	29	218,635	4,364	421	71	99.8%
2011	Wet	231	219,289	9,103	17	223,443	4,407	487	72	99.8%
2012	Dry	285	225,684	181	20	220,494	4,822	491	78	99.7%
2013	Dry	226	239,670	30	7	234,649	4,516	462	81	99.8%
2014	Dry	199	213,017	43	21	208,267	4,320	419	74	99.8%
2015	Dry	217	187,227	0	10	184,862	1,864	436	75	99.7%
2016	Dry	210	190,662	92	25	188,193	2,069	442	75	99.7%
2017	Wet	217	199,600	697	15	198,017	1,762	457	75	99.7%
2018	Dry	238	222,247	0	18	220,079	1,605	501	80	99.7%
2019	Wet	224	210,206	0	20	207,822	1,853	472	79	99.7%
2020	Dry	226	251,142	0	9	248,776	1,822	476	78	99.8%
2021	Dry	217	216,245	0	16	213,901	1,822	457	80	99.8%
2022	Dry	225	226,438	0	15	223,846	2,050	474	83	99.8%
2023	Wet	210	200,930	0	24	198,133	2,317	434	71	99.7%
2024	Wet	217	223,240	0	18	220,370	2,357	457	73	99.8%
Minimum		199	187,227	0	7	184,862	1,605	419	71	99.7%
Maximum		285	252,483	10,358	29	248,776	4,822	501	83	99.8%
Wet Year Average		220	212,920	2,585	22	211,877	3,123	454	73	99.8%
Dry Year Average		226	226,537	165	15	223,003	3,174	462	78	99.8%
Overall Average		224	221,090	1,133	18	218,552	3,153	459	76	99.8%

1. Irrigation seasons defined as days between March and October where Woodward Releases are greater than 0 cfs except for 2000 and 2012 where one rotation in January (1/9/2000-1/20/2000) and (1/9/2012-1/25/2012) was included
2. U3 Ranch Deliveries estimated as 11 cfs (24 hour) delivery when the flow in the Main Supply Canal is greater than 100 cfs based on operations reports provided by the District
3. (Woodward Reservoir Inflows + U3 Ranch Deliveries) / (Deliveries from Joint Supply Canal + Ordered Spillage + MSC Precip)

Intentionally Left Blank

Table 5-14. Annual Water Balance for Woodward Reservoir.

Year	Hydrologic Year Type	Irrigation Seasons Number of Days ¹	Inflow (af)			Outflow (af)				Change in Reservoir Storage	Performance Indicators
			Woodward Reservoir Inflows	Reservoir Precip	Tributary Inflow	Woodward Reservoir Releases	WTP Deliveries	Reservoir Seepage	Reservoir Evap		Reservoir Efficiency ²
2005	Wet	224	200,316	2,120	4,554	193,686	1,326	16,896	8,384	-13,301	94.2%
2006	Wet	215	228,276	1,670	8,876	192,116	11,707	16,501	8,167	10,332	85.3%
2007	Dry	221	245,708	780	1,292	208,085	16,794	17,295	9,301	-3,696	90.8%
2008	Dry	222	247,753	980	2,681	213,401	16,479	17,185	9,235	-4,886	91.4%
2009	Dry	224	239,510	1,253	3,687	194,560	19,376	16,836	8,751	4,928	87.5%
2010	Wet	224	218,635	2,107	4,244	184,904	16,931	16,614	8,130	-1,593	89.7%
2011	Wet	231	223,443	1,236	6,512	181,810	17,927	16,545	8,081	6,829	86.4%
2012	Dry	285	220,494	1,445	6,101	187,830	18,426	16,791	8,880	-3,887	90.4%
2013	Dry	226	234,649	525	693	191,012	20,148	16,740	9,294	-1,328	89.5%
2014	Dry	199	208,267	1,347	1,928	167,063	18,840	14,950	8,185	2,506	87.9%
2015	Dry	217	184,862	782	1,235	144,133	15,406	15,878	8,294	3,169	85.4%
2016	Dry	210	188,193	2,212	3,692	152,276	17,001	16,172	8,051	597	87.2%
2017	Wet	217	198,017	1,327	3,007	162,088	20,124	16,747	8,027	-4,635	90.0%
2018	Dry	238	220,079	1,647	2,190	179,987	21,046	16,310	8,277	-1,704	89.8%
2019	Wet	224	207,822	1,401	3,732	170,694	21,690	15,677	8,445	-3,551	90.3%
2020	Dry	226	248,776	663	3,560	192,145	23,984	15,937	8,801	12,130	85.4%
2021	Dry	217	213,901	1,148	4,567	176,584	24,043	15,809	8,705	-5,524	91.4%
2022	Dry	225	223,846	1,076	2,937	192,736	23,863	16,801	9,299	-14,840	95.1%
2023	Wet	210	198,133	1,834	8,451	162,791	21,196	17,060	8,523	-1,151	88.3%
2024	Wet	217	220,370	1,365	4,975	160,972	23,715	16,674	8,394	16,956	81.5%
Minimum		199	184,862	525	693	144,133	1,326	14,950	8,027	-14,840	81.5%
Maximum		285	248,776	2,212	8,876	213,401	24,043	17,295	9,301	16,956	95.1%
Wet Year Average		220	211,877	1,633	5,544	176,132	16,827	16,589	8,269	1,236	88.2%
Dry Year Average		226	223,003	1,155	2,880	183,318	19,617	16,392	8,756	-1,045	89.3%
Overall Average		224	218,552	1,346	3,946	180,444	18,501	16,471	8,561	-132	88.9%

1. Irrigation seasons defined as days between March and October where Woodward Releases are greater than 0 cfs except for 2000 and 2012 where one rotation in January (1/9/2000-1/20/2000) and (1/9/2012-1/25/2012) was included

2. (Woodward Reservoir Releases + WTP Deliveries) / (Woodward Reservoir Inflows + Reservoir Precip + Tributary Inflow)

Intentionally Left Blank

Table 5-15. Annual Water Balance for Main Supply Canal Below Woodward Reservoir and Main Distributary Canal.

Year	Hydrologic Year Type	Irrigation Seasons Number of Days ¹	Inflow (af)			Outflow (af)						Performance Indicators
			Woodward Reservoir Releases	OID Spills to Main Canal	Total Supply	Lateral Deliveries	Ordered Spillage	Operational Spillage	MDC Evap	Direct Diversion from Main Canal	MDC Canal Seepage	Lower MSC and MDC Efficiency ²
2005	Wet	224	193,686	2,645	196,331	172,357	260	0	503	918	22,293	88.4%
2006	Wet	215	192,116	3,888	196,004	157,361	10,358	0	484	917	26,884	86.0%
2007	Dry	221	208,085	3,883	211,968	179,228	1,081	0	537	1,122	30,000	85.6%
2008	Dry	222	213,401	3,243	216,644	189,130	277	0	542	1,146	25,549	88.0%
2009	Dry	224	194,560	2,470	197,030	165,672	280	0	520	1,036	29,522	84.8%
2010	Wet	224	184,904	3,078	187,982	164,588	260	0	487	896	21,751	88.2%
2011	Wet	231	181,810	2,932	184,742	149,347	9,103	0	489	878	24,925	86.2%
2012	Dry	285	187,830	4,035	191,865	160,821	181	0	526	1,635	28,702	84.8%
2013	Dry	226	191,012	4,419	195,431	170,661	30	0	545	2,083	22,112	88.4%
2014	Dry	199	167,063	2,553	169,616	153,051	43	0	501	1,476	14,545	91.1%
2015	Dry	217	144,133	1,732	145,865	117,456	0	0	520	1,686	26,203	81.7%
2016	Dry	210	152,276	1,934	154,210	125,758	92	0	505	1,597	26,259	82.6%
2017	Wet	217	162,088	2,284	164,371	134,701	697	0	508	1,230	27,236	83.1%
2018	Dry	238	179,987	3,402	183,389	145,863	0	0	543	1,510	35,473	80.4%
2019	Wet	224	170,694	3,411	174,105	147,535	0	0	532	1,323	24,715	85.5%
2020	Dry	226	192,145	3,061	195,206	164,707	0	0	530	1,463	28,505	85.1%
2021	Dry	217	176,584	3,061	179,645	144,195	0	0	545	1,309	33,596	81.0%
2022	Dry	225	192,736	3,061	195,796	155,388	0	0	560	1,425	38,424	80.1%
2023	Wet	210	162,791	5,275	168,066	152,684	0	0	482	983	13,918	91.4%
2024	Wet	217	160,972	13,715	174,687	164,574	0	0	496	953	8,665	94.8%
Minimum		199	144,133	1,732	145,865	117,456	0	0	482	878	8,665	80.1%
Maximum		285	213,401	13,715	216,644	189,130	10,358	0	560	2,083	38,424	94.8%
Wet Year Average		220	176,132	4,654	180,786	155,393	2,585	0	498	1,012	21,298	88.0%
Dry Year Average		226	183,318	3,071	186,389	155,994	165	0	531	1,457	28,241	84.5%
Overall Average		224	180,444	3,704	184,148	155,754	1,133	0	518	1,279	25,464	85.9%

1. Irrigation seasons defined as days between March and October where Woodward Releases are greater than 0 cfs except for 2000 and 2012 where one rotation in January (1/9/2000-1/20/2000) and (1/9/2012-1/25/2012) was included

2. (Lateral Deliveries + Ordered Spillage + Direct Diversion from Main Canal) / (Woodward Reservoir Releases + OID Spills to Main Canal)

Intentionally Left Blank

Table 5-16. Annual Water Balance for District Laterals.

Year	Hydrologic Year Type	Irrigation Seasons Number of Days ¹	Inflows (af)		Outflows (af)					Performance Indicators
			Lateral Deliveries	District Pumping	Farm Deliveries	Lateral Seepage	Lateral Evap	Surface Water Deliveries (to Urban Lands)	Lateral Spillage	Laterals Efficiency ²
2005	Wet	224	172,357	5,974	149,026	4,713	654	0	23,937	83.6%
2006	Wet	215	157,361	5,239	134,999	4,942	660	89	21,911	83.1%
2007	Dry	221	179,228	6,024	154,867	5,080	732	89	24,485	83.6%
2008	Dry	222	189,130	5,656	166,238	5,103	738	89	22,617	85.4%
2009	Dry	224	165,672	4,917	145,008	4,896	707	89	19,889	85.1%
2010	Wet	224	164,588	3,078	137,253	5,149	663	89	24,512	81.9%
2011	Wet	231	149,347	2,601	113,106	5,310	666	11	32,855	74.4%
2012	Dry	285	160,821	4,399	130,863	5,517	716	45	28,080	79.2%
2013	Dry	226	170,661	6,120	145,601	5,195	742	0	25,243	82.4%
2014	Dry	199	153,051	5,388	139,080	4,574	682	183	13,919	87.9%
2015	Dry	217	117,456	5,264	104,556	4,988	708	204	12,263	85.4%
2016	Dry	210	125,758	3,699	108,582	4,827	687	189	15,171	84.0%
2017	Wet	217	134,701	3,938	118,592	4,988	692	141	14,225	85.6%
2018	Dry	238	145,863	3,229	132,911	5,471	739	171	9,800	89.3%
2019	Wet	224	147,535	4,538	133,509	5,149	724	153	12,538	87.9%
2020	Dry	226	164,707	4,630	152,579	5,195	721	261	10,581	90.3%
2021	Dry	217	144,195	5,348	135,331	4,990	741	290	8,190	90.7%
2022	Dry	225	155,388	5,043	133,931	5,153	762	383	20,202	83.7%
2023	Wet	210	152,684	3,660	122,995	4,827	656	236	27,630	78.8%
2024	Wet	217	164,574	2,900	124,137	4,988	675	312	37,361	74.3%
	Minimum	199	117,456	2,601	104,556	4,574	654	0	8,190	74.3%
	Maximum	285	189,130	6,120	166,238	5,517	762	383	37,361	90.7%
	Wet Year Average	220	155,393	3,991	129,202	5,008	674	129	24,371	81.2%
	Dry Year Average	226	155,994	4,976	137,462	5,082	723	166	17,537	85.6%
	Overall Average	224	155,754	4,582	134,158	5,053	703	151	20,270	83.8%

1. Irrigation seasons defined as days between March and October where Woodward Releases are greater than 0 cfs except for 2000 and 2012 where one rotation in January (1/9/2000-1/20/2000) and (1/9/2012-1/25/2012) was included

2. (Farm Deliveries + Surface Water Deliveries (to Urban Lands)) / (Lateral Deliveries + District Pumping)

Intentionally Left Blank

Table 5-17. Annual Water Balance for Irrigated Lands

Year	Hydrologic Year Type	Irrigation Seasons Number of Days ¹	Applied Water Balance							Precipitation Balance					Change in Storage	
			Inflows (af)			Outflows (af)				Performance Indicators	Inflows (af)		Outflows (af)			
			Farm Deliveries	Direct Diversion from Main Canal	Private Pumping	IL ET _{aw}	IL Tailwater	IL Deep Percolation _{aw}	Crop Consumptive Use Fraction ²		IL Precip	IL Deep Percolation _{precip}	IL ET _{precip}	IL Runoff of Precip		
2005	Wet	224	149,026	918	44,962	121,865	2,611	70,430	62.5%	78,157	43,819	36,096	99	-1,857		
2006	Wet	215	134,999	917	47,150	121,447	2,603	59,016	66.3%	66,919	38,075	34,843	253	-6,252		
2007	Dry	221	154,867	1,122	65,705	146,497	3,139	72,057	66.1%	28,078	7,187	19,145	9	1,737		
2008	Dry	222	166,238	1,146	57,105	143,635	3,078	77,777	64.0%	37,005	17,899	20,903	87	-1,884		
2009	Dry	224	145,008	1,036	53,253	132,706	2,844	63,747	66.6%	47,696	15,155	24,814	187	7,540		
2010	Wet	224	137,253	896	38,725	112,788	2,417	61,668	63.8%	79,971	33,923	36,780	102	9,166		
2011	Wet	231	113,106	878	50,703	112,904	2,419	49,364	68.6%	47,653	24,891	34,391	94	-11,723		
2012	Dry	285	130,863	1,635	64,194	132,770	2,845	61,076	67.5%	55,274	18,756	22,914	54	13,550		
2013	Dry	226	145,601	2,083	64,212	144,331	3,093	64,472	68.1%	20,133	9,631	19,881	19	-9,398		
2014	Dry	199	139,080	1,476	64,692	137,896	2,955	64,397	67.2%	60,032	25,529	23,202	340	10,961		
2015	Dry	217	104,556	1,686	83,613	142,392	2,373	45,091	75.0%	29,337	10,090	21,160	44	-1,956		
2016	Dry	210	108,582	1,597	74,442	127,951	2,742	53,928	69.3%	70,919	33,582	35,007	269	2,061		
2017	Wet	217	118,592	1,230	74,599	136,094	2,916	55,410	70.0%	42,773	23,719	24,030	109	-5,084		
2018	Dry	238	132,911	1,510	65,255	139,773	2,995	56,908	70.0%	53,061	18,712	24,580	188	9,581		
2019	Wet	224	133,509	1,323	58,232	134,076	2,873	56,115	69.4%	57,909	23,824	34,649	29	-593		
2020	Dry	226	152,579	1,463	61,413	145,439	3,117	66,900	67.5%	27,151	10,662	19,551	28	-3,090		
2021	Dry	217	135,331	1,309	74,699	147,137	3,153	61,048	69.6%	44,631	15,904	18,654	379	9,694		
2022	Dry	225	133,931	1,425	86,585	151,660	3,250	67,031	68.3%	40,786	9,522	17,731	435	13,099		
2023	Wet	210	122,995	983	51,426	122,156	2,618	50,630	69.6%	68,838	47,949	34,408	110	-13,628		
2024	Wet	217	124,137	953	64,549	132,385	2,837	54,417	69.8%	51,094	22,301	27,591	30	1,172		
Minimum		199	104,556	878	38,725	112,788	2,373	45,091	62.5%	20,133	7,187	17,731	9	-13,628		
Maximum		285	166,238	2,083	86,585	151,660	3,250	77,777	75.0%	79,971	47,949	36,780	435	13,550		
Wet Year Average		220	129,202	1,012	53,793	124,214	2,662	57,131	67.5%	61,664	32,312	32,848	103	-3,600		
Dry Year Average		226	137,462	1,457	67,931	141,016	2,965	62,869	68.3%	42,842	16,052	22,295	170	4,324		
Overall Average		224	134,158	1,279	62,276	134,295	2,844	60,574	68.0%	50,371	22,556	26,516	143	1,155		

1. Irrigation seasons defined as days between March and October where Woodward Releases are greater than 0 cfs except for 2000 and 2012 where one rotation in January (1/9/2000-1/20/2000) and (1/9/2012-1/25/2012) was included
2. $ET_{aw} / (\text{Farm Deliveries} + \text{Direct Diversions from Main Canal} + \text{Private Pumping})$

Intentionally Left Blank

Table 5-18. Annual Water Balance for Drainage System.

Year	Hydrologic Year Type	Irrigation Seasons Number of Days ¹	Inflows (af)					Outflows (af)			
			Lateral Spillage	IL Tailwater	IL Runoff of Precip	Pumping for Groundwater Transfer ²	Stormwater Runoff	Seepage/GW Interception	DS Evap	District Outflow	GW Transfer
2005	Wet	224	23,937	2,611	99	0	2,895	2,132	353	27,058	0
2006	Wet	215	21,911	2,603	253	0	2,573	2,141	350	24,848	0
2007	Dry	221	24,485	3,139	9	0	1,115	2,120	386	26,242	0
2008	Dry	222	22,617	3,078	87	0	1,541	2,094	383	24,847	0
2009	Dry	224	19,889	2,844	187	0	2,018	2,104	367	22,467	0
2010	Wet	224	24,512	2,417	102	0	3,463	2,157	339	27,998	0
2011	Wet	231	32,855	2,419	94	0	2,111	2,018	343	35,118	0
2012	Dry	285	28,080	2,845	54	0	2,483	2,163	372	30,927	0
2013	Dry	226	25,243	3,093	19	0	927	1,945	393	26,945	0
2014	Dry	199	13,919	2,955	340	0	2,818	2,070	382	17,581	0
2015	Dry	217	12,263	2,373	44	1,007	1,611	1,990	375	13,926	1,007
2016	Dry	210	15,171	2,742	269	0	3,445	2,100	368	19,159	0
2017	Wet	217	14,225	2,916	109	0	2,108	1,869	367	17,123	0
2018	Dry	238	9,800	2,995	188	0	2,669	2,157	378	13,119	0
2019	Wet	224	12,538	2,873	29	0	2,960	2,083	376	15,942	0
2020	Dry	226	10,581	3,117	28	0	1,410	1,977	368	12,790	0
2021	Dry	217	8,190	3,153	379	0	2,388	2,085	390	11,635	0
2022	Dry	225	20,202	3,250	435	1,809	2,285	1,818	385	23,967	1,809
2023	Wet	210	27,630	2,618	110	0	3,642	2,157	358	31,484	0
2024	Wet	217	37,361	2,837	30	0	2,723	2,163	358	40,431	0
Minimum		285	37,361	3,250	435	1,809	3,642	2,163	393	40,431	1,809
Maximum		199	8,190	2,373	9	0	927	1,818	339	11,635	0
Wet Year Average		220	24,371	2,662	103	0	2,809	2,090	355	27,500	0
Dry Year Average		226	17,537	2,965	170	235	2,059	2,052	379	20,300	235
Overall Average		224	20,270	2,844	143	141	2,359	2,067	369	23,180	141

1. Irrigation seasons defined as days between March and October where Woodward Releases are greater than 0 cfs except for 2000 and 2012 where one rotation in January (1/9/2000-1/20/2000) and (1/9/2012-1/25/2012) was included
2. Groundwater transfer to Mountain House in 2015.

Intentionally Left Blank

5.8 WATER SUPPLY RELIABILITY

SSJID requires a firm water supply to meet crop irrigation demand. The primary crops grown in SSJID consist of almonds and other permanent crops that are typically high-value crops that supply increasing regional, national, and international food demands. Other primary crops include forage and feed crops to sustain beef cattle and dairy herds in the region. A commercially viable agricultural operation requires a firm water supply. SSJID's water supply is considered very reliable, and was discussed in detail previously in Section 4.

Nevertheless, regional and statewide water planning efforts have the potential to affect the future reliability of SSJID's water supplies. Specific programs and planning efforts that may have a significant impact on the future availability and reliability of these water supplies are described below.

5.8.1 Bay-Delta Water Quality Control Plan

The State Water Board is responsible for adopting and updating the Water Quality Control Plan for the San Francisco Bay/Sacramento–San Joaquin Delta Estuary (Bay-Delta Plan), which establishes water quality control measures and flow requirements needed to provide reasonable protection of beneficial uses in the watershed.

In December 2018, the State Water Resources Control Board (SWRCB) adopted amendments to the Water Quality Control Plan for the San Francisco Bay/Sacramento-San Joaquin Delta Estuary (Bay-Delta Plan Amendment) which, if and when implemented, may have an impact on the Stanislaus River. The SWRCB is required by law to regularly review this plan. The adopted Bay-Delta Plan Amendment was developed with the stated goal of increasing salmonid populations in three San Joaquin River tributaries (the Stanislaus, Merced, and Tuolumne Rivers) and the Bay-Delta. The Bay-Delta Plan Amendment requires the release of between 30-50% of the unimpaired flow on the three tributaries from February through June in every year type.

If the Bay-Delta Plan Amendment is implemented as adopted, certain modeling reflects there will be significant impacts in some years to the ability of the Bureau of Reclamation to meet its obligations under the 1988 Stipulation and Agreement to provide formula water to the Districts in dry and critically dry years when inflow into New Melones is below 600,000 AF. This could reduce the minimum projected supply amount of 225,000 AF/year as planned for by SSJID in this UWMP. The SWRCB has stated that it intended to implement the Bay-Delta Plan Amendment on the Stanislaus River by the year 2022, assuming all required approvals are obtained by that time; however, implementation of the Bay-Delta Plan Amendment remains uncertain for multiple reasons.

Over a dozen lawsuits were filed in both state and federal courts, including challenges by the Oakdale Irrigation District and SSJID, challenging the SWRCB's adoption of the Bay-Delta Plan Amendment. Judgments were issued in favor of the SWRCB in each of those lawsuits, but

multiple parties appealed those judgments and the matter remains unresolved in the courts. Secondly, the Bay-Delta Plan Amendment is not self-implementing and the Board must formally allocate responsibility for the flow requirements to water right holders. Such an allocation of responsibility must consider the senior water rights of both OID and SSJID who jointly hold adjudicated pre-1914 rights and other senior appropriative rights.

Many stakeholders throughout California, including the State and Federal Government, have opted to explore alternatives to the Bay-Delta Plan, such as a voluntary agreement that would provide reasonable protection to fish and wildlife beneficial uses while balancing the needs of all water users. Both OID and SSJID have participated in voluntary agreement negotiations. Based on these uncertainties, SSJID has opted to make no near-term planning assumptions related to the implementation of the Bay-Delta Plan Amendment for the purposes of this 2025 AWMP. Should conditions change, SSJID will revise and re-adopt the 2025 AWMP to reflect changes to its impacted water supply.

5.8.2 SGMA and Groundwater Sustainability Plan

The Sustainable Groundwater Management Act of 2014 (SGMA) establishes a framework for local control of groundwater resources while requiring sustainable management of groundwater basins. SGMA requires the formation of Groundwater Sustainability Agencies (GSAs) with the authority to develop, adopt, and implement Groundwater Sustainability Plans (GSPs) designed to achieve sustainable groundwater management by 2040.

Since the passage of SGMA in 2014, SSJID has actively collaborated with regional partners in the Eastern San Joaquin Subbasin to support sustainable groundwater management and regulatory compliance. In 2017, SSJID entered into a Memorandum of Agreement with the Cities of Escalon and Ripon to form the South San Joaquin Groundwater Sustainability Agency (SSJGSA), which was formalized as a joint powers authority in 2020.

The SSJGSA is a member agency of the Eastern San Joaquin Groundwater Authority (ESJGWA), a coordinated group of 16 GSAs that collectively manage the Eastern San Joaquin Subbasin. The ESJGWA developed a Groundwater Sustainability Plan (GSP), which was adopted in 2020, revised in 2022, and was approved by DWR in 2023. The ESJGWA amended its GSP in 2024 in response to feedback from the California Department of Water Resources. The Amended 2024 GSP was submitted to DWR in January 2025 and is pending review by DWR.

The 2024 Amended GSP continues to rely on GSAs to actively implement projects and management actions to improve groundwater levels and avoid the onset of undesirable results as compared to 2015 conditions. Member GSAs rely on the ESJGWA to perform groundwater monitoring, annual reporting, fill data gaps, administer the domestic well mitigation program, and coordinate with GSAs to ensure GSP deadlines and commitments are met.

Achieving sustainability will require certain GSAs to reduce groundwater overdraft by offsetting groundwater demands with surface water and groundwater recharge or curtailment of pumping. These changes introduce uncertainty in future groundwater availability and may affect agricultural production, land use decisions, and regional economic conditions.

SSJID has a long history of effective conjunctive management of surface water and groundwater resources, and protecting this ability is of highest strategic priority. The combined effects of SGMA implementation and reduced surface water reliability—driven implementation of Bay-Delta Water Quality Control Plan requirements could create compounding challenges for maintaining surface water supply reliability within the District.

5.9 WATER MANAGEMENT OBJECTIVES

For over 115 years, SSJID has strived for excellence in serving its customers and has adapted to fit the devolving needs of its community. Today, SSJID not only delivers water for irrigated agriculture, it also is treating and delivering treated drinking water for over 215,000 residents, providing recreation opportunities at Woodward Reservoir, providing drainage service for urban areas, and endeavoring to provide retail electric service at a significant saving from PGE rates. The following sections are embodied in the SSJID publication, *Responsible and Reliable: Strategic Plan 2024*.

SSJID's Mission:

“SSJID provides the utmost value for its agricultural, urban, and business community by protecting and delivering vital resources with exceptional service.”

SSJID's Vision:

“SSJID delivers high quality water and reliable power to the communities we serve. We lead in innovation and respect our history, our employees, and our environment.”

SSJID's Water Supply, Infrastructure Treatment, and Distribution Goals:

- 1.0 Protect and preserve the District's Water Rights.
- 2.0 Implement the Water Master Plan to ensure the long-term operational efficiency of the water delivery system and improve the level of service to customers.
- 3.0 Demonstrate success and effectively communicate progress and results to District customers, stakeholders, and employees.
- 4.0 Provide high quality, cost-conscious, potable water in compliance with all state and Federal drinking water standards.

SSJID's Finance and Rates Goals:

- 1.0 Establish and maintain rates that are fair, reasonable, and financially sustainable.
- 2.0 Evaluate, update, and modernize all District fees, and charges for services.
- 3.0 Maintain financial reserves to adequately moderate risks, supply foreseeable cash needs, and protect the District's bond ratings.
- 4.0 Maintain and optimize efficient financial accounting, monitoring, and budgeting practices.
- 5.0 Develop Capital funding strategy. 6. Enhance Enterprise Resource Planning.

SSJID's Workforce and Culture Goals:

- 1.0 Maintain an effectively sized and structured workforce.
- 2.0 Promote understanding, professional growth, and the development of our employees.
- 3.0 Improve process of evaluating team member performance.

SSJID's Customer and Community Relations Goals:

- 1.0 Enhance engagement and brand awareness within the community and region.
- 2.0 Measure and improve customer satisfaction.
- 3.0 Develop regional partnerships to advance mutual organizational goals and outcomes.

SSJID's Legislative and Regulatory Goals:

- 1.0 Proactively and strategically implement and communicate the District's legislative positions.
- 2.0 Foster relationships with local legislators and their staff.
- 3.0 Create and foster alliances and coalitions to advance common advocacy positions and objectives.

SSJID's Retail Electric Goals:

- 1.0 Continue to foster internal and external District communications and keep the community apprised of progress through the duration of the legal process and the transition phase.

- 2.0 Win the eminent domain lawsuit and arrive at a feasible purchase price for the electric distribution assets.
- 3.0 Develop a transition plan that anticipates and manages material risks of the project.
- 4.0 Execute the transition plan in a manner that anticipates and neutralizes the risks of the project.
- 5.0 Involve the public in significant processes and decisions such as rate design and public benefits planning.
- 6.0 Qualify the electric utility acquisition debt for the best achievable credit rating by the date when the debt must be rated.
- 7.0 Establish rates at least 15 percent below PG&E.
- 8.0 Maintain financial independence from water ratepayers.

Towards these goals, SSJID has implemented a number of water management strategies and embarked on a number of water planning efforts, including (but not limited to) the following:

- **Affordable, Tiered Pricing Structure.** As described in Sections 3.9 and 7.3.2 of this AWMP, SSJID offers water at an affordable price compared to the cost of groundwater pumping.
- **Van Groningen Regulating Reservoir** (1992)
- **Northwest Reservoir (SIDE Project)** (2003)
- **Main Distribution Canal (MDC) Automation and SCADA Integration** (initial upgrades and ongoing enhancements)
- **SCADA Master Control Center and Communication System Improvements** (including microwave network)
- **Drain Outflow Measurement and Improvement Program** (including Drain Outflow Improvement Study and Measurement Plan)
- **Irrigation Enhancement Project (Division 9 Project)** (2012), including East Basin, pump station, and pressurized delivery system
- **Lateral System Automation and Downstream Control Improvements** (including float valves and level sensors)
- **Water Master Plan (2022) and Capital Improvement Plan (CIP)** (ongoing phased modernization framework)
- **Water Budget Tool Development** (2020–2021)
- **Water Information System (WIS) Planning and Development**

These projects collectively improve SSJID’s ability to manage limited water supplies with greater precision and flexibility, supporting efficient operations under increasingly variable hydrologic conditions and regulatory constraints.

5.10 WATER USE EFFICIENCY

Water use efficiency is a core consideration in SSJID’s operations. As stated above, SSJID’s mission is to provide exceptional water service and value to its agricultural, urban, and business community, while also protecting these vital resources. Efficient water use at all levels benefits this mission by conserving or utilizing water for maximal benefit to SSJID’s customers and downstream water users. Key water use components and water use efficiency in SSJID are quantified in the sections below.

5.10.1 Water Use Efficiency Components

Four types of water use serve as the basis for water use efficiency calculations: crop water use, agronomic water use, environmental water use, and recoverable flows. These water use efficiency components are quantified in Table 5-19 and are described in the sections below.

5.10.1.1 Crop Water Use

Crop water use, or crop consumptive use, in SSJID represents the portion of total applied water withdrawn by crops that is evaporated, transpired, incorporated into products or crops, or otherwise removed from the immediate water environment for consumptive use (ASCE, 2016).

In the water budget presented in this AWMP, crop water use of applied water is referred to as evapotranspiration of applied water (ET_{aw}). ET_{aw} is quantified as an outflow of the IDC root zone water budget described in Section 5.2.2. Table 5-19 summarizes the ET_{aw} in SSJID in 2020 through 2024.

5.10.1.2 Agronomic Water Use

Agronomic water use in SSJID represents the portion of total applied water that is directly used for crop cultivation practices, but that is not consumed by crops (i.e., excluding ET_{aw}). Sample agronomic water uses include salt leaching, seedbed preparation, and climate control. In SSJID, agronomic water uses mainly include pre-irrigation of corn for germination, and additional small water volumes used for frost protection. Table 5-19 summarizes these total combined agronomic water uses in SSJID.

Agronomic water use associated with corn pre-irrigation was estimated in prior analyses using SSJID TruePoint delivery data and water budget information. For each corn field, the first irrigation event (assumed to represent pre-irrigation) was evaluated, and ET_{aw} occurring between the first and second irrigation was subtracted to avoid double-counting. On average, approximately four inches of water were applied during the first irrigation, with approximately three inches consumed as ET_{aw} , resulting in an estimated one inch of agronomic water use. For planning purposes, a uniform application of 1.0 inch was assumed for all corn acreage.

Surface water supplied by SSJID, primarily originating from New Melones Reservoir, is of high quality with low salinity and total dissolved solids. As a result, and when considering winter precipitation and crop-specific leaching requirements, no appreciable salt leaching requirement was assumed within the District.

Agronomic water use for frost protection was estimated assuming a typical, average required frost protection application rate of 0.15 inches per hour for cold-sensitive crops on days when the minimum, average, or maximum temperature was below 32°F (assuming 12, 18, or 24 hours of potential frost protection is needed, based on which temperature, respectively, was below 32°F). Crops requiring potential frost protection were assumed to vary by month. The only crops considered to require frost protection in early spring (February and March) were early blooming orchards (cherries, peaches).

Table 5-19. Water Use Efficiency Components.

Water Use Efficiency Component	Year (Surface Water Allotment, Hydrologic Year Type)					Average
	2020	2021	2022	2023	2024	
	(Full, Dry)	(Partial, Dry)	(Full, Dry)	(Full, Wet)	(Full, Wet)	
Crop Consumptive Use (IL ET_{aw})	145,439	147,137	151,660	122,156	132,385	139,755
Agronomic Use¹	700	700	700	700	700	700
Environmental Use²	0	0	0	0	0	0
Recoverable Flows of Total Water Supply						
Recoverable Flows to Groundwater (IL Deep Percolation ^{aw} , Seepage ³)	118,991	117,986	129,702	89,026	87,363	108,614
Recoverable Surface Flows (District Outflow, Spillage ⁴ , Outside Deliveries ⁵)	60,786	41,184	46,796	62,203	92,353	60,664
Total Recoverable Flows of Total Water Supply	179,777	159,170	176,498	151,228	179,716	169,278

¹ Assuming pre-irrigation of corn and frost protection.

² Assuming negligible environmental use within SSJID service area (Stanislaus River instream flow requirements are met before irrigation releases and considered to be outside the SSJID service area).

³ Seepage includes MDC Canal Seepage, Reservoir Seepage (from Woodward Reservoir), MSC Canal Seepage, Lateral Seepage, and Seepage/GW Interception (from Drainage System).

⁴ Spillage includes Operational Spillage and Ordered Spillage.

⁵ Outside deliveries include U3 Ranch Deliveries, WTP Deliveries, Surface Water Deliveries (to Urban Lands), and GW Transfer.

5.10.1.3 Environmental Water Use

As described in Section 5.5.2, water is released from New Melones Reservoir to meet instream flow requirements in the Stanislaus River. These instream requirements are met before irrigation diversions are made. Releases to the Stanislaus River for environmental purposes therefore reduce the remaining supplies available for irrigation and are not met from SSJID’s irrigation water supplies.

In wet years, ordered spillage is released at Goodwin Dam. Ordered spillage includes water routed through the distribution system to spill points as part of water transfers and deliveries for environmental enhancement in downstream waterways. While these outflows provide environmental benefits to the Eastern San Joaquin Subbasin and the Stanislaus and San Joaquin rivers, they are accounted as recoverable flows for the purposes of this AWMP.

5.10.1.4 Recoverable Flows

Recoverable flows in SSJID encompass the portion of total water supply that are neither consumed by crops nor evaporated from the distribution system, but that are recoverable for other beneficial uses within SSJID, downstream of SSJID, or in other areas overlying the Eastern San Joaquin Subbasin. Recoverable flows to groundwater are represented in this water budget by deep percolation of applied water from the Irrigated Lands accounting center (IL Deep Percolation_{aw}) and seepage from SSJID's canals, laterals, drains, and from Woodward Reservoir. Recoverable flows to surface flows include District outflows from District drains, operational spillage, ordered spillage, and deliveries made from the SSJID distribution system to areas outside the SSJID agricultural area (U3 Ranch Deliveries, WTP Deliveries, Surface Water Deliveries (to Urban Lands), and GW Transfer).

Table 5-19 summarizes the combined recoverable flows from SSJID in 2015 through 2019.

5.10.2 Water Use Efficiency Fraction

The water use efficiency fraction most applicable to SSJID is the water management fraction (WMF). As depicted in Figure 5-1, there is extensive interconnection between the various accounting centers due, in part, to recapture of water by SSJID. The District also provides significant volumes of surface water and groundwater to surrounding communities through deliveries, spillage, drainage, and seepage. This water is available for beneficial uses outside the District's agricultural service area. Conjunctive management efforts by SSJID also promote the sustainable recharge of groundwater in wetter years and recovery in drier years. These methods of water recovery, recharge, and reuse result in higher levels of system performance and water use efficiency than would otherwise occur.

The water management fraction (WMF) can be calculated by comparing the consumptive use of applied water (ET_{aw}) and all recoverable flows in the SSJID distribution system and irrigated lands to the total water supplies available within SSJID. The WMF is calculated on an annual basis at the water supplier scale according to Equation 5-2, using the water volumes reported in Table 5-19:

$$\text{Total Water Supply Basis: WMF} = (\text{IL ET}_{\text{aw}} + \text{IL Deep Percolation}_{\text{aw}} + \text{Seepage} + \text{District Outflow} + \text{Spillage} + \text{Outside Deliveries}) / (\text{Total Water Supply}^8) \quad [5-2]$$

Over the 2020 to 2024 period, the average WMF was 96.6 percent (Table 5-20). This high WMF indicates that essentially all of SSJID’s water supply is used to meet irrigation demands or is recoverable for beneficial use by down gradient surface water and groundwater users. The only water budget flow path that is not recoverable or consumed by crops in SSJID is evaporation from the SSJID distribution system.

Table 5-20. Water Use Efficiency Fraction (Total Water Supply Basis).

Year ¹	Distribution and Drainage System Evaporation	Total Water Supply ¹ (af/year)	Water Management Fraction
2015	10,498	325,216	96.8%
2016	10,462	306,307	96.6%
2017	11,087	328,158	96.6%
2018	10,089	273,385	96.3%
2019	9,996	312,101	96.8%
Year ¹	Distribution and Drainage System Evaporation	Total Water Supply ¹ (af/year)	Water Management Fraction
2015	10,498	325,216	96.8%
2016	10,462	306,307	96.6%
2017	11,087	328,158	96.6%
2018	10,089	273,385	96.3%
2019	9,996	312,101	96.8%

¹ Total water supply includes Deliveries from Joint Supply Canal, District Pumping, Private Pumping, OID Spills to Main Canal, Ordered Spillage, Tributary Inflow, Stormwater Runoff, and Pumping for Groundwater Transfer.

⁸ Total water supply is equal to the sum of Deliveries from Joint Supply Canal, District Pumping, Private Pumping, OID Spills to Main Canal, Ordered Spillage, Tributary Inflow, Stormwater Runoff, and Pumping for Groundwater Transfer.

6 CLIMATE CHANGE

6.1 INTRODUCTION

Climate change has the potential to directly impact SSJID’s surface water supply and to indirectly impact groundwater supplies. SSJID is committed to adapting to climate change in a manner that protects the District’s water resources for the maximum benefit while continuing to maintain a reliable, affordable, high quality water supply for agriculture. This section discusses the potential effects of climate change on SSJID and its water supply and describes the potential impacts of climate change on water supply, water quality, and water demand. Finally, this section identifies actions currently underway or those which could be implemented to help mitigate future impacts of climate change.

6.2 POTENTIAL CLIMATE CHANGE EFFECTS

SSJID recognizes the several potential effects of climate change identified by the scientific community including reduced winter snowpack, more variable and extreme weather conditions, shorter winters, and increased evaporative demand. Additionally, climate change could affect water quality through increased flooding and erosion; greater concentration of contaminants, if any, in the water supply; and warmer water, which could lead to increased growth of algae and other aquatic plants. Rising sea level and increased risks of flooding are also potential effects of climate change.

The discussion of potential climate change effects in this AWMP focuses on the potential effects related to SSJID’s water supply and demand and does not discuss potential effects of rising sea level or increased flooding risks except in the context of reduced firm yield. SSJID is not located within or adjacent to the Sacramento-San Joaquin River Delta and does not expect to be directly impacted by rising sea level. Additionally, SSJID does not serve a flood management role and stormwater management from urban or rural development is the responsibility of the municipalities or developer.

SSJID has not pursued any additional climate change impact analysis since the 2020 AWMP and has included the previous published information in this 2025 AWMP. More recently, SSJID through its participation with the ESJGWA through the SSJGSA, analyzed the potential for climate change impacts on groundwater sustainability. The 2024 Eastern San Joaquin Subbasin GSP contain an analysis of projected groundwater balance impacts based on projected conditions baseline scenario with climate change reflected (PCBL-CC). Groundwater modeling conducted by the ESJGWA for the 2024 GSP is based on the DWR 2070 Central Tendency climate change scenario. The 2024 GSP reports an increase of 26,000 acre-feet of average annual groundwater pumping subbasin-side due to increased water demands only partially offset by increased runoff and reduced snowmelt.

6.2.1 Sources of Information Describing Potential Climate Change Effects

Potential climate change effects are evaluated based on existing historical data and projections of future hydrology and climate parameters, such as temperature and precipitation. The information sources used to quantify these historical values and projected effects are described below

6.2.1.1 Hydrology

In this AWMP, the potential impacts of climate change on SSJID water supplies are evaluated using historical full, natural flow in the Stanislaus River at Goodwin Dam from 1901 to 2020. Projected changes to Stanislaus River hydrology over the next 100 years are also assessed.

Historical full natural flows along the Stanislaus River are reported by DWR's California Cooperative Snow Surveys, available through the California Data Exchange Center. Projected changes to Stanislaus River flows are derived from studies prepared by the United States Bureau of Reclamation (USBR) and DWR.

More recent projections of future streamflow along the Stanislaus River at Goodwin Dam were also extracted from climate change models described by Pierce et al. (2018) in contribution to California's Fourth Climate Change Assessment. Projected future monthly and annual flows were quantified from 32 coarse-resolution (~100 km) global climate models (GCMs). Results of the GCMs were bias corrected, downscaled, and then applied to a land surface model to estimate soil moisture, runoff, surface energy fluxes, and other parameters. Results were reported for several models across two key climate change scenarios: scenario RCP 4.5, in which greenhouse gas emissions peak around 2040 and then decline thereafter, with projected statewide warming of 2-4°C; and scenario RCP 8.5, in which greenhouse gas emissions continue to rise through 2050 and plateau around 2100, with projected statewide warming of 4-7°C.

Like the report by Pierce et al. (2018), projected future flows along the Stanislaus River were obtained from projections developed using GCMs reported by USBR (Gangopadhyay and Pruitt, 2011). Key results of these studies have been summarized as part of this section, with additional details in Section 6.2.2.

6.2.1.2 Climate Parameters

The potential impacts of climate change on crop water demand in SSJID are evaluated using historical data for precipitation, temperature, and ET_o in and around SSJID. In particular, the USBR study West-Wide Climate Risk Assessment: Irrigation Demand and Reservoir Evaporation Projections (USBR 2015) is presented to evaluate the potential effects of climate change on crop evapotranspiration (ET).

Historical precipitation data within SSJID are reported by the Manteca CIMIS station (#70; 1987-2020). To view longer-term changes in precipitation, data were also summarized for the National Oceanic and Atmospheric Administration (NOAA) weather station #49073 "Turlock

Number 2” for the period 1927⁹-2019. This station was selected for its longer period of available data, and because of its similarity to precipitation reported at the Manteca CIMIS station during overlapping periods of record (in contrast with other weather stations in the surrounding area).

Historical temperature and ET_o data in an agricultural setting are reported by the Manteca CIMIS station (#70; 1987-2020), located in the SSJID service area. While other CIMIS stations are located near the SSJID service area, only the Manteca station is located within it. To prevent differences in station locations from obscuring changes in temperature and ET_o over time, only the Manteca CIMIS station is evaluated in this section.

6.2.2 Summary of Potential Climate Change Effects

This section summarizes the possible effects of climate change on changes in timing and quantity of runoff as well as changes in climate parameters and crop requirements.

6.2.2.1 Changes in Timing of Runoff

As a result of increased precipitation as rain instead of snow with a projected rise in global temperatures, the timing of runoff has been and will likely continue to shift to earlier in the year. The effect of this is decreased runoff in the April-July period, as described in the following sections. This may result in increased groundwater use compared to surface water to meet demand in these months and is further addressed in Sections 6.4 and 6.5.

6.2.2.1.1 Historical Runoff

Based on available historical data and projected future streamflow, the amount of annual runoff occurring during the spring-summer period from April through July has decreased over the past century and will likely continue to decrease in the next century.

Stanislaus River unimpaired flow (i.e., full, natural flow) from 1900 to 2020 at Goodwin Dam shows a decreasing trend in April to July runoff as a percentage of total water year runoff over the past century (Figure 6-1). Conversely, increasingly more runoff has occurred during the fall-winter period, outside of the irrigation season.

6.2.2.1.2 Projected Runoff

The percentage of total runoff occurring during the April-July period is expected to continue to decline over the next century. Streamflow projections reported by Pierce et al. (2018) for California’s Fourth Climate Change Assessment suggest such future trends in Stanislaus River flows under average climate change conditions (simulation CanESM2). If greenhouse gas emissions continue to rise through 2050 and plateau around 2100 (scenario RCP 8.5, with projected statewide warming of 4-7°C), flows in April to July are expected to decrease from approximately 70 percent of total runoff in 2010 to just over 55 percent, on average, by 2099.

⁹ Incomplete precipitation data from NOAA weather station #49073 are available at beginning in 1893, though the generally complete data record begins in 1927.

However, if greenhouse gas emissions peak around 2040 and then decline thereafter (scenario RCP 4.5, with projected statewide warming of 2-4°C), flows in April to July are expected to decrease to just over 60 percent, on average, by 2099.

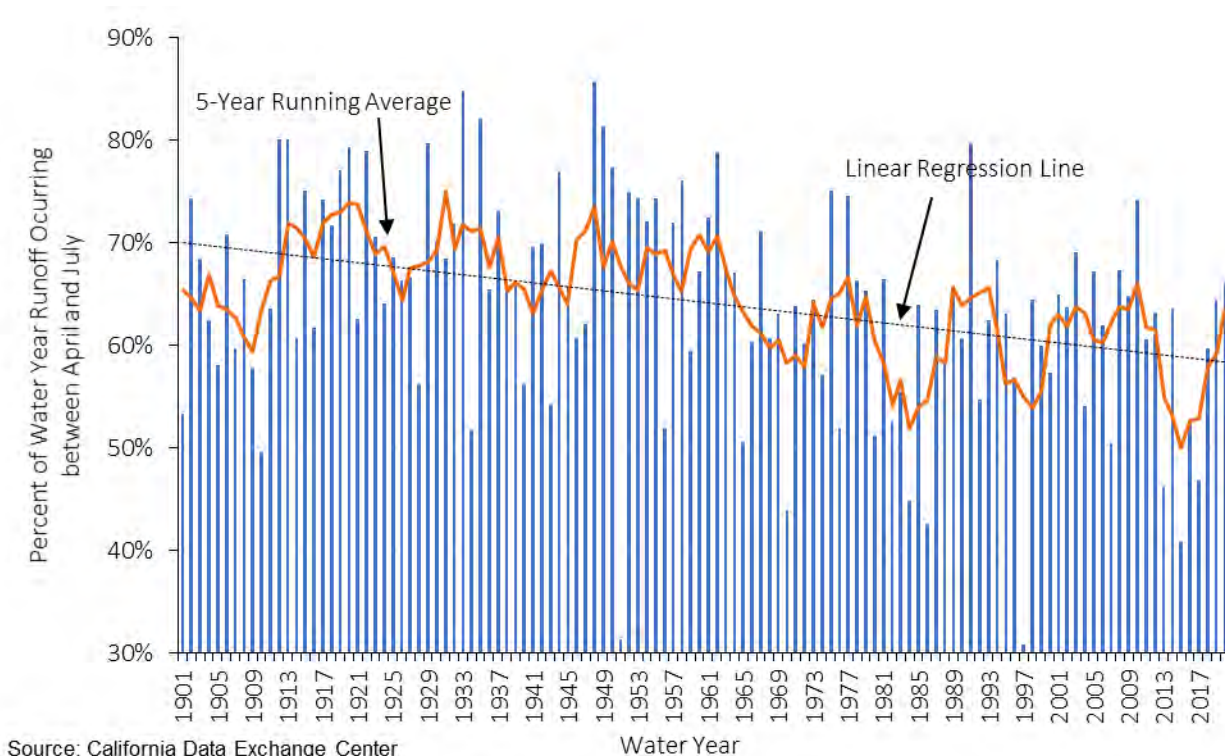
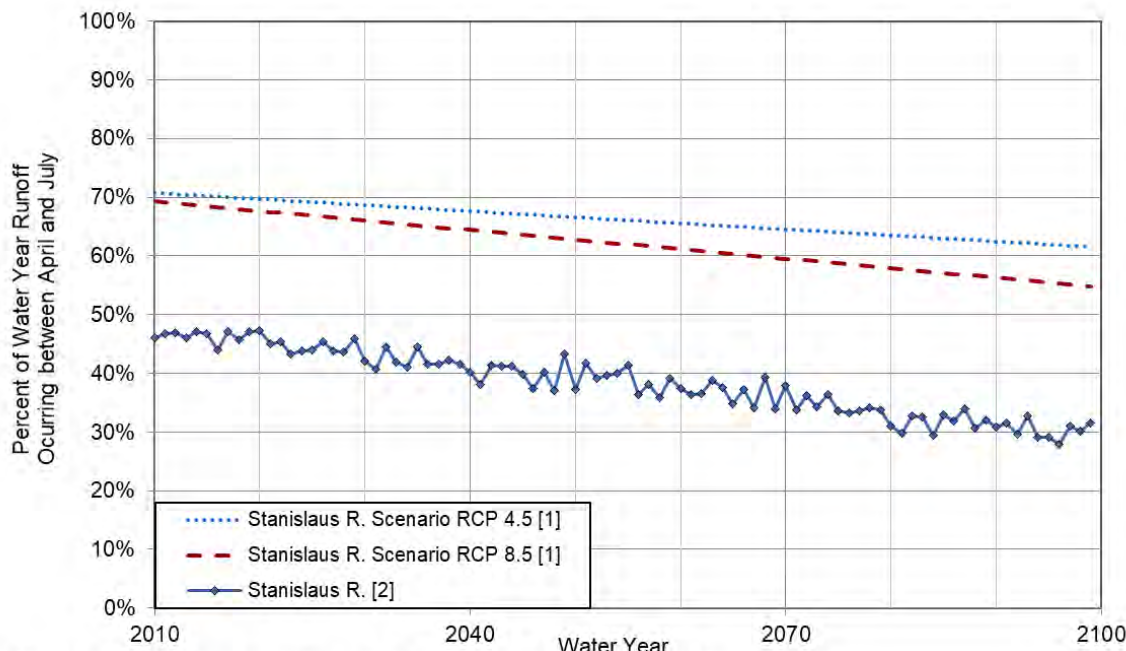

Figure 6-1. Unimpaired Runoff for Stanislaus River at Goodwin Dam, April – July Runoff as a Percent of Total Water Year Runoff

Figure 6-2 also shows the projected changes in April to July runoff for the Stanislaus River at New Melones Reservoir as projected by Gangopadhyay and Pruitt, 2011 for comparison. Projected trends are similar for each.



[1] Pierce et al., 2018. (Fitted regression curve shown for "average" simulation, CanESM2)
 [2] Gangopadhyay and Pruitt, 2011

Figure 6-2. Projected Unimpaired Runoff, April-July Runoff as a Percent of Total Water Year Runoff for Stanislaus River (Pierce et al, 2018 and Gangopadhyay and Pruitt, 2011).

6.2.2.2 Changes in Total Runoff.

Projections reported by Pierce et al. (2018) and Gangopadhyay and Pruitt (2011) suggest that in addition to timing changes in runoff, total runoff could decrease over the next 100 years.

The Pierce et al. study provides annual estimates of Stanislaus River runoff at Don Pedro Reservoir through 2099 using a number of alternative climate change simulations. Of these simulations, four were selected by California’s Climate Action Team as priority models for research contributing to California’s Fourth Climate Change Assessment:

- HadGEM2-ES – A “warmer/drier” simulation
- CNRM-CM5 – A “cooler/wetter” simulation
- CanESM2 – An “average” simulation
- MIROC5 – A “complement” simulation that is most unlike the first three, providing the best coverage of all possibilities

The total water year runoff decade average from these simulations was calculated and compared to the values observed in the 2010s (2010-2019) to illustrate relative changes over time. As shown in Figure 6-3, the total water year runoff in the Stanislaus River varies considerably between periods and among simulations, with the highest expected runoff in the “cooler/wetter” (CNRM-CM5) simulation and the lowest expected runoff in the “warmer/drier” (HadGEM2-ES)

and “complement” (MIROC5) simulations. The mean runoff of all simulations is expected to vary between approximately 80% and 110% of the runoff in the 2010s.

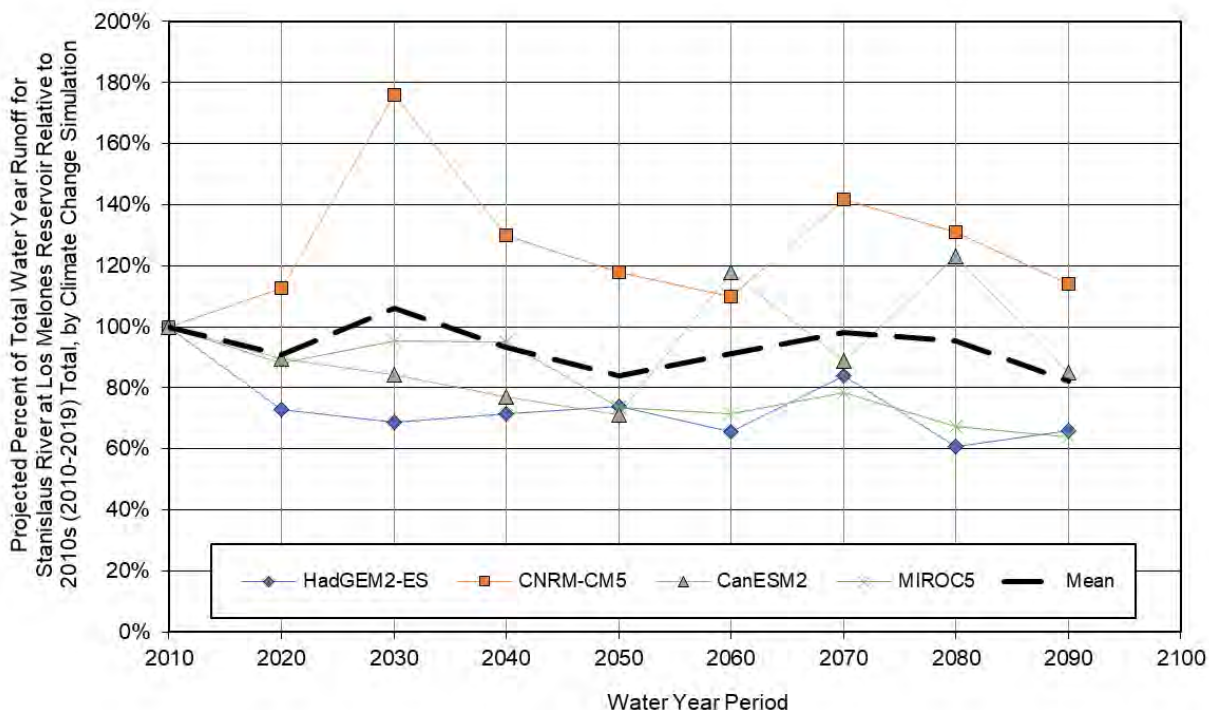

Figure 6-3. Average Total Water Year Projected Stanislaus River Runoff at Los Melones Reservoir, by Decade and by Climate Change Simulation (Source: Pierce et al., 2018).

Projections of total runoff over the next century reported by Gangopadhyay and Pruitt (2011) for the Stanislaus River at New Melones Lake also suggest a slight decrease in total runoff (Figure 6-4). The figure shows the 5th percentile, median, and 95th percentile annual runoff for 2010 to 2100 based on 112 separate hydrologic projections.

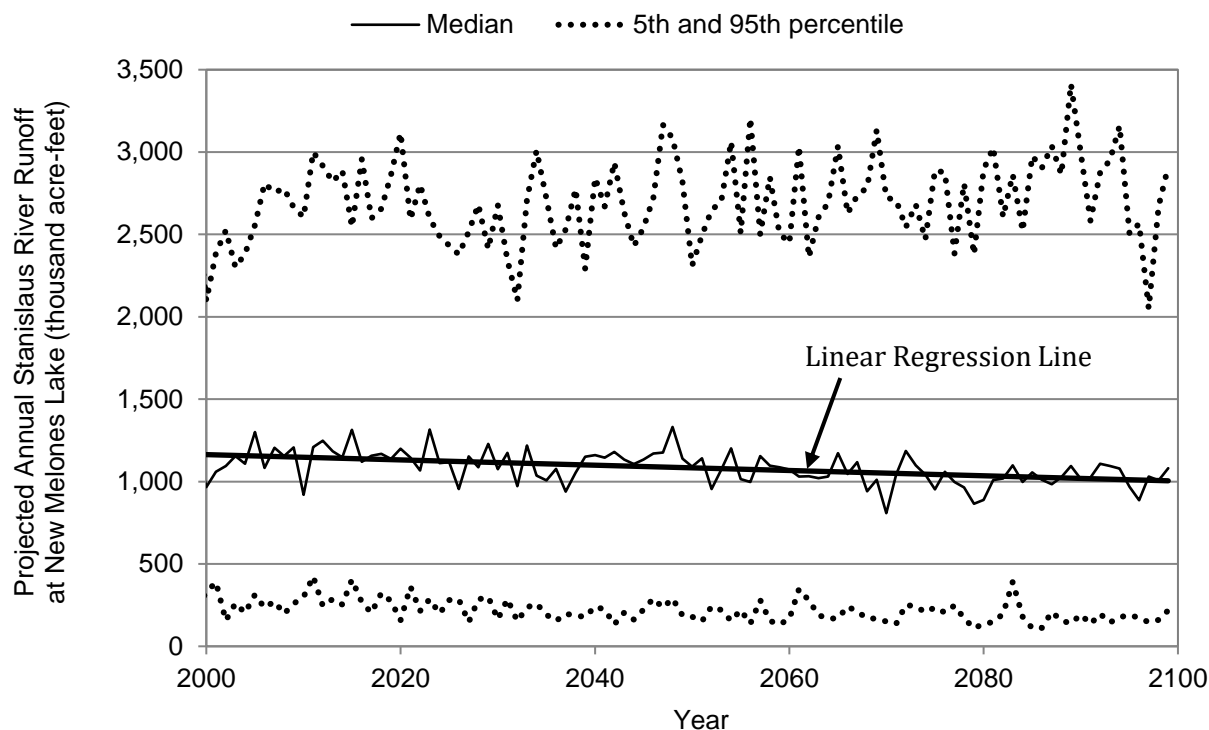

Figure 6-4. Annual Stanislaus River Runoff at New Melones Reservoir Based on 112 Hydrologic Projections (Gangopadhyay and Pruitt, 2011)

6.2.2.3 Changes in Climate Parameters and Crop Evapotranspiration

Climate change has the potential to affect crop evapotranspiration and resulting irrigation water demands within SSJID. Changes in precipitation, temperature, and atmospheric CO₂ each affect crop evapotranspiration (ET) and net irrigation water requirements (NIWR).

Historical precipitation, air temperature, and reference ET (ET_o) are first summarized to provide context for the projected changes in climate parameters due to climate change. Precipitation records in and around SSJID, including annual precipitation, mean annual precipitation, and cumulative departure¹⁰ from the mean annual precipitation, are shown in Figure 6-5 and Figure 6-6.

¹⁰ Cumulative departure curves are useful to illustrate long-term hydrologic characteristics and trends during drier or wetter periods relative to the mean annual precipitation or streamflow. Downward slopes of the cumulative departure curve represent drier periods relative to the mean, while upward slopes represent wetter periods relative to the mean. A steep slope indicates a drastic change in dryness or wetness during that period, whereas a flat slope indicates average conditions during that period, regardless of whether the total cumulative departure falls above or below zero.

Between 1988 and 2020, the mean annual precipitation in SSJID was approximately 12.4 inches per year (Figure 6-5). NOAA data from a weather station approximately 30 miles south of SSJID in Turlock, CA has a mean annual precipitation similar to SSJID, at 12 inches per year over the same period. As shown in Figure 6-6, wet periods (indicated by a positive slope in the cumulative departure from mean curve) have historically occurred over a shorter duration than drier periods (indicated by a negative slope in the cumulative departure from mean curve), even since the 1930s and 1940s. Notable drought periods, including 1976-1977, 1987-1992, and 2012-2016, are seen generally occurring at the end of extended drier periods, ending with the beginning of a significantly wetter period.

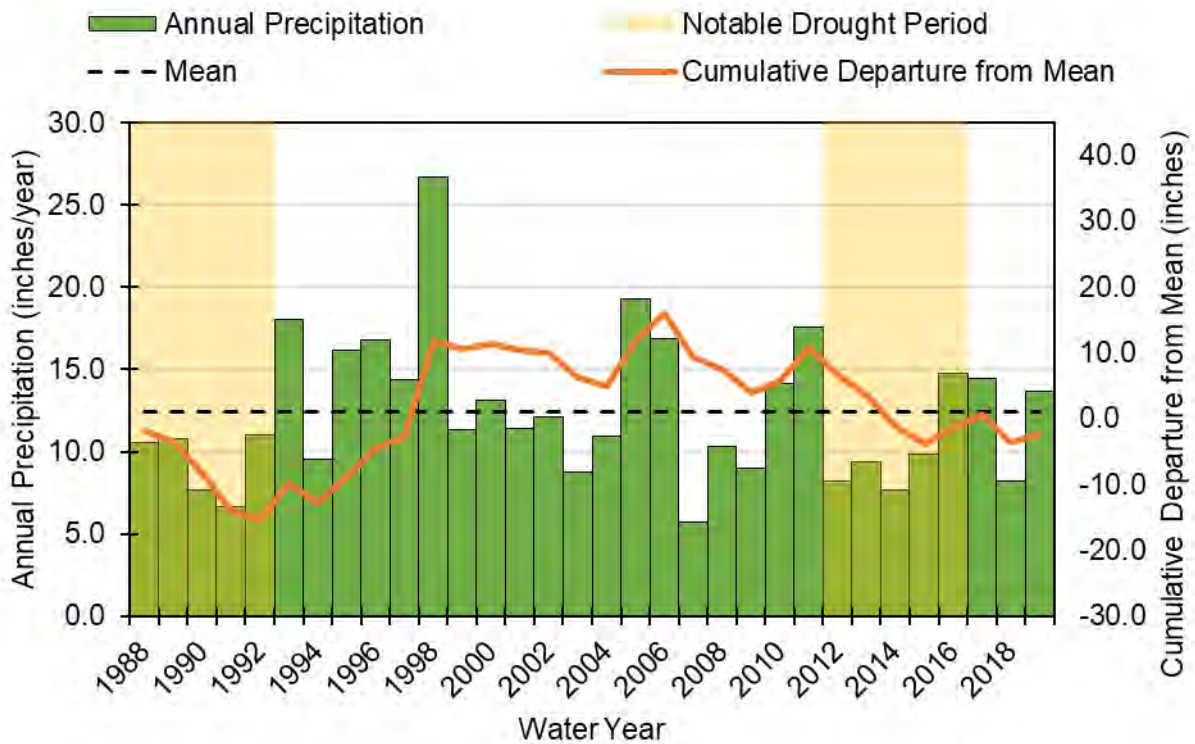

Figure 6-5. Historical Annual Precipitation and Cumulative Departure from the Mean Annual Precipitation at Manteca CIMIS Station.

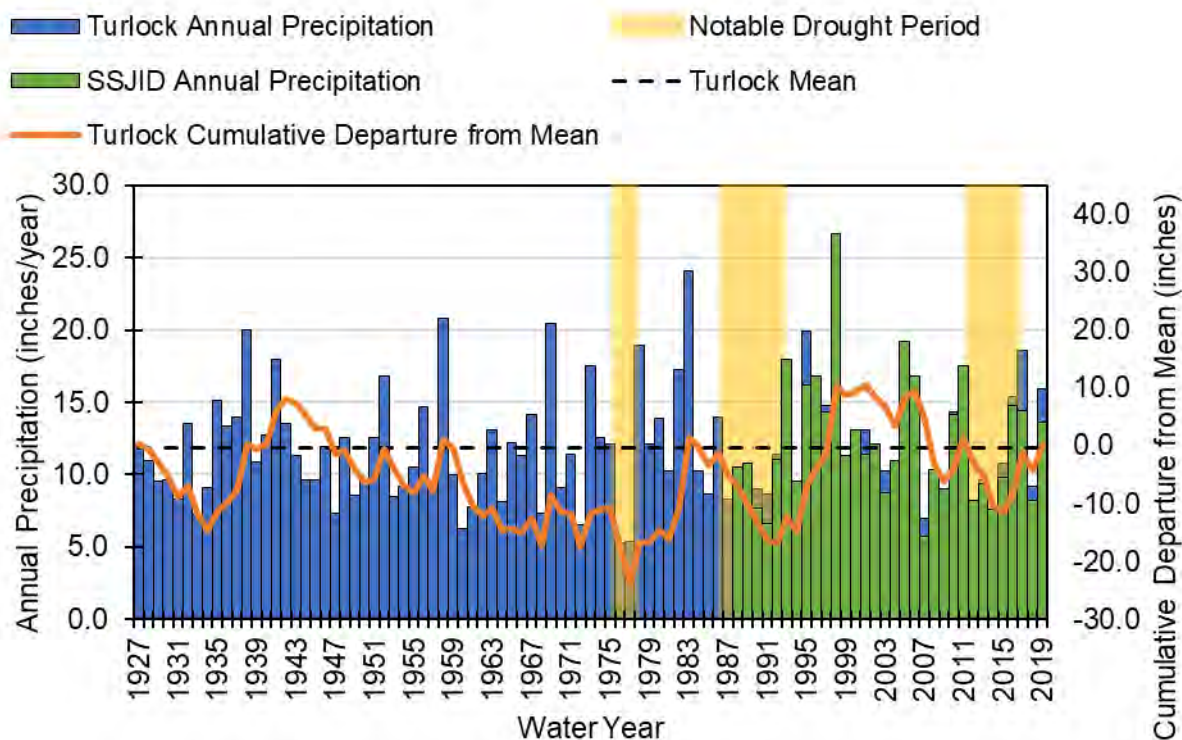

Figure 6-6. Historical Annual Precipitation and Cumulative Departure from the Mean over the last century for Turlock, CA, about 30 miles from SSJID.

Figure 6-7 shows the mean daily temperatures at the Manteca CIMIS station near SSJID. CIMIS stations are specially sited within agricultural areas to provide climate parameters that are most representative of the conditions experienced by irrigated agriculture. Between water years 1988 and 2020, the average daily air temperatures in SSJID have averaged approximately 60°F, while the maximum and minimum daily temperatures have averaged 74°F and 47°F, respectively.

Figure 6-8 shows the annual reference evapotranspiration (ET_o) rate reported at the Manteca CIMIS station near SSJID. Between water years 1988 and 2020, the average annual ET_o was approximately 52 inches per year, ranging from a high of nearly 59 inches in 1990 to a low of 46 inches in 1998.

While a number of methods have been used to project future climate change and related impacts on crop water demands, Global Climate Models (GCMs) are considered a standard for climate change analyses. In particular, the U.S. Bureau of Reclamation released a report entitled West-Wide Climate Risk Assessment: Irrigation Demand and Reservoir Evaporation Projections (USBR 2015) in February 2015. As changes in precipitation, temperature, and atmospheric CO₂ affect crop evapotranspiration (ET) and net irrigation water requirements (NIWR), the study uses climate change projections to calculate future ET and NIWR throughout the Western U.S., including California’s Central Valley. Projections for the Central Valley were developed for

DWR planning units, which are typically used to evaluate statewide water supplies and demands as part of the California Water Plan. As shown in Figure 6-9, SSJID’s service area falls within Planning Unit 607 (PU607).

GCMs have been used to project future climate change and impacts on crop evapotranspiration and resulting irrigation water demands. This section describes potential changes in crop ET, while impacts on NIWR are described in Section 6.4, below.

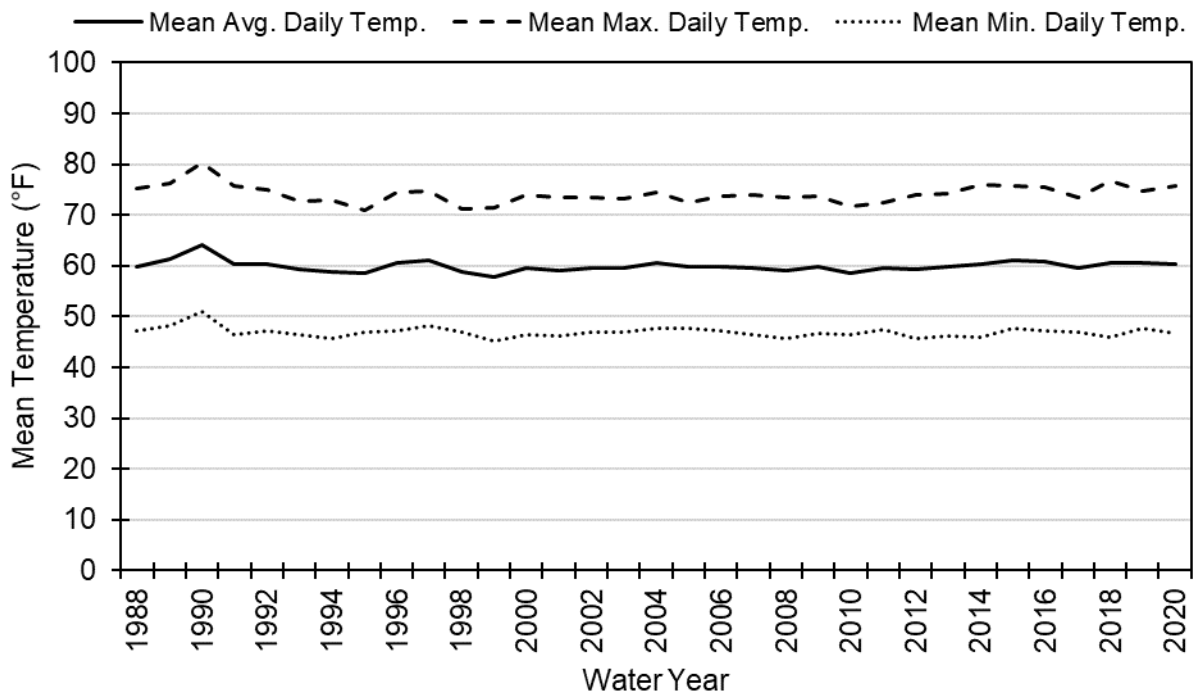

Figure 6-7. Historical Mean Daily Temperatures at the Manteca CIMIS Station.³

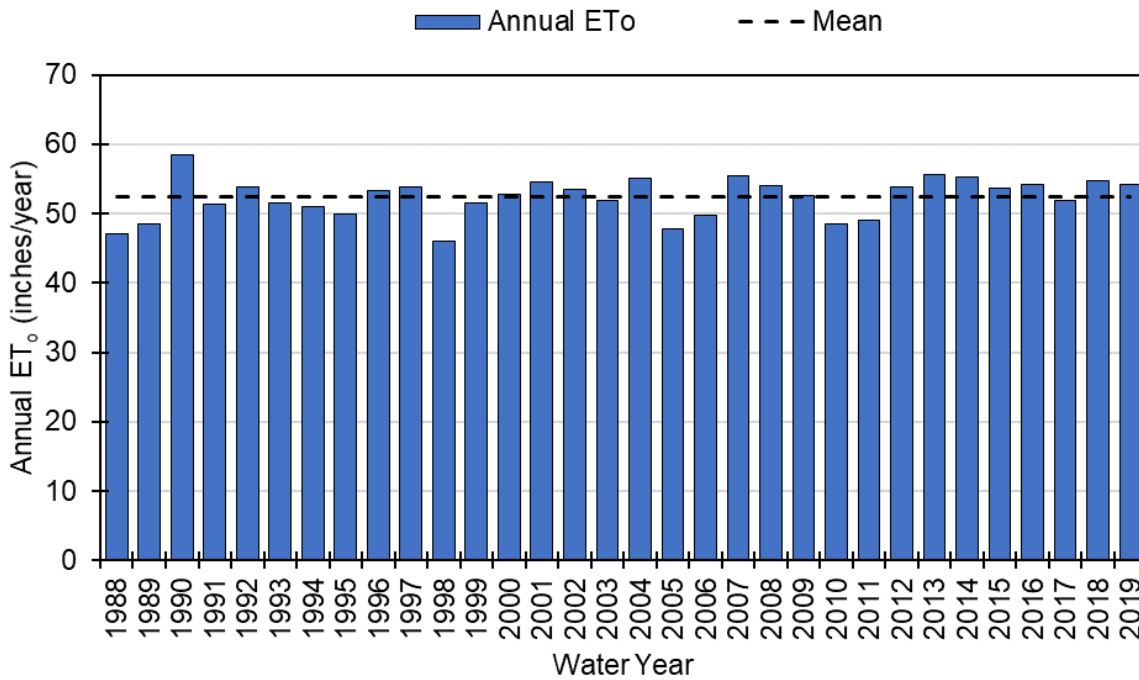
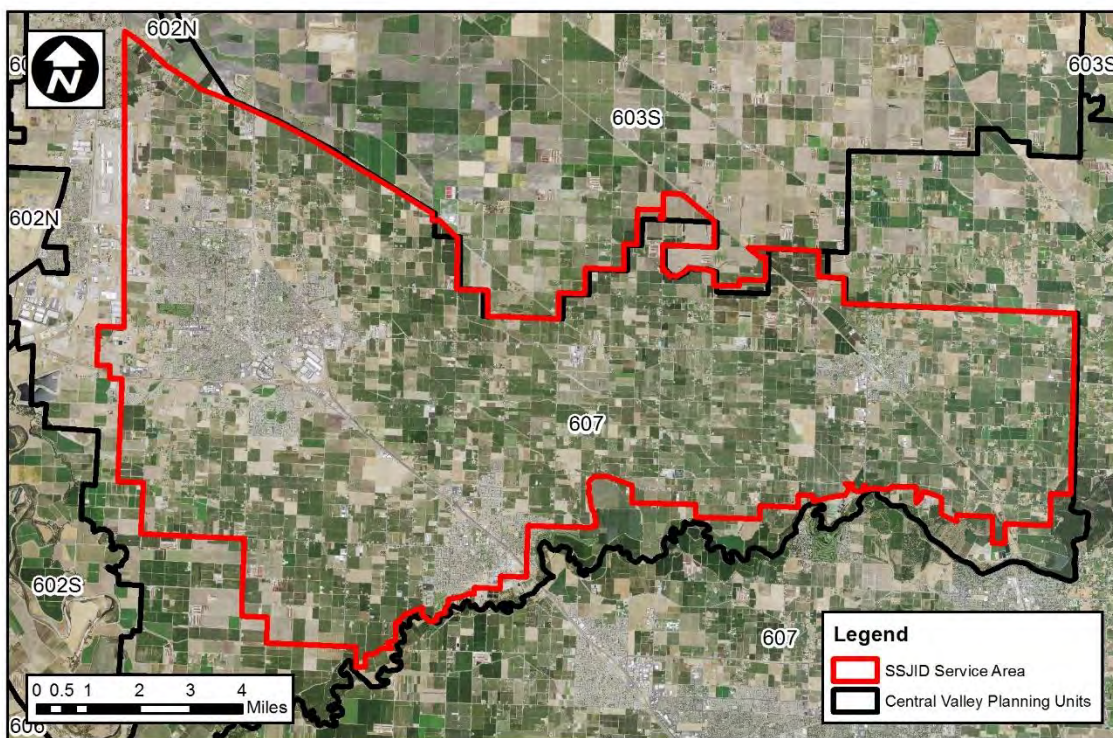

Figure 6-8. Historical Annual Reference ET at the Manteca CIMIS Station.¹¹



¹¹ The sensor used in the late 1980s was likely replaced or repaired after 1990 because many values were out of range at end of that year (not included in the data presented here), but this issue was corrected at the start of 1991.

Figure 6-9. CMIP3 Planning Unit 607.

The U.S. Bureau of Reclamation's study utilizes future climate projections from GCMs to simulate crop ET under various climate change scenarios, and to estimate resulting changes in NIWR. The specific dataset selected for predicting future irrigation demands was the World Climate Research Program (WCRP) Coupled Model Intercomparison Project Phase 3 (CMIP3). Original GCM projections are developed at a spatial resolution of 100 to 250 km. In order to develop data on a usable scale to support local and regional planning, CMIP3 projections were downscaled to 12 km square sections using the statistical algorithm known as bias comparison and spatial disaggregation (BCSD). One hundred and twelve BCSD-CMIP3 projections were created based on combinations of GCM and potential future greenhouse gas emission scenarios.

Crop ET and NIWR were estimated using a model simulating crop growth and irrigation demands over time under baseline and modified climate scenarios. Specifically, the ET Demands model was used to estimate crop ET and NIWR. The ET Demands model is a daily root zone water balance simulation that applies a dual crop coefficient approach to quantify crop ET and other flows into and out of the root zone. Reference ET was calculated based on climate projections for each of the five modeled climate scenarios using the Food and Agricultural Organization (FAO) Report 56 (FAO-56) reference ET approach. The GCMs climatic conditions were limited to only daily maximum and minimum temperature and daily precipitation. Therefore, other climate parameters needed to estimate reference ET, such as solar radiation, humidity, and wind speed, were approximated for baseline and future time periods using empirical equations (USBR 2015). In order to evaluate potential impacts of changes in temperature on the timing of crop growth and overall season length, simulations were conducted assuming both static and dynamic crop phenology. To simulate dynamic phenology, growing degree day (GDD) based crop curves were used. By incorporating GDD into the analysis, projected changes in temperature influence the timing and speed of crop growth. Increased temperatures result in earlier, shorter growing seasons for annual crops. Crop evapotranspiration is projected to increase in areas where perennial crops are grown and smaller increases are projected for areas where annual crops are grown.

Potentially, each of the 112 climate projections could be simulated in the ET Demands model to develop projections of future ET and NIWR; however, due to the wide variety of crop types and agricultural practices in the West this would create enormous computation and data handling requirements. Instead, five different climate change scenarios were created using the ensemble hybrid formed delta method. The future conditions of warm-dry, warm-wet, hot-dry, hot-wet and central tendency were used. Three future periods for these five conditions were selected to project climate change, including the 2020s (2010-2039), 2050s (2040-2069) and 2080s (2070-2099).

Average air temperature in PU607 is projected to increase for each of the five scenarios for each future period as shown in Figure 6-10. Projected temperature increases range from 1.2 to 2.5

deg. F during the 2020s period, 2.6 to 4.4 deg. F during the 2050s period, and 3.8 to 6.6 deg. F during the 2080s period.

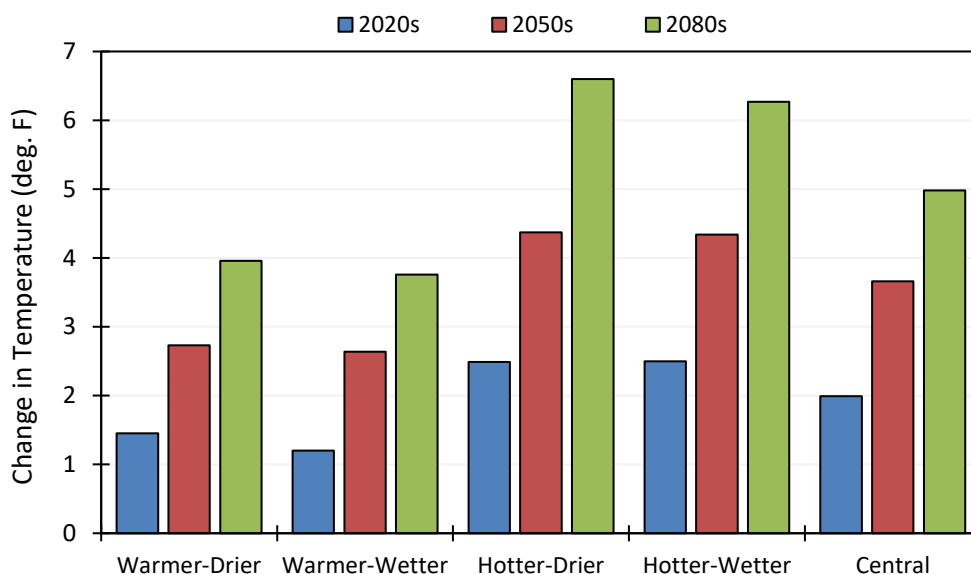

Figure 6-10. WWCRA Projected Temperature Change.

Potential changes in precipitation resulting from climate change are relatively uncertain for California’s Central Valley due to uncertainty in the future position of the jet stream. As a result, some GCMs and emission scenario combinations predict increased precipitation under climate change, while other combinations predict decreased precipitation. Percent changes in projected average annual precipitation for PU607 are shown in Figure 6-11. Under wetter conditions, increases in precipitation of 3.9 to 9.5 percent between the 2020s and the 2080s are predicted, while under drier conditions, decreases in precipitation of -8.8 to -15.7 percent between the 2020s and the 2080s are predicted. The central tendency results in a predicted slight decrease in precipitation of -2.0 percent during the 2020s to -3.8 percent during the 2080s period.

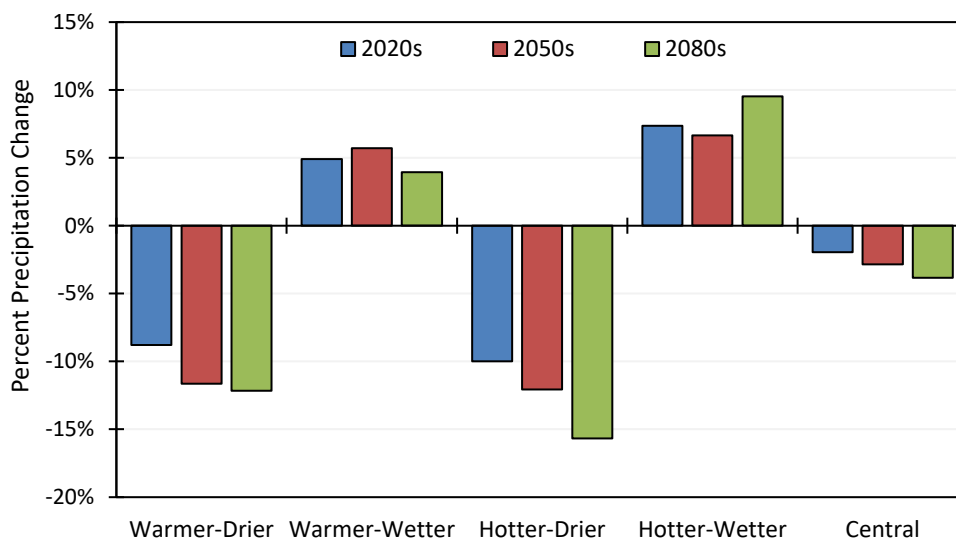

Figure 6-11. WWCRA Projected Precipitation Change.

From the projected temperature and precipitation results, WWCRA used impact models to develop projected reference ET and actual ET estimates. The results are shown below in Figure 6-12 and Figure 6-13, respectively. Increases in both reference ET and actual ET are projected. Projected reference ET increases range from 1.7 to 3.6 percent during the 2020s period, 3.7 to 6.1 percent during the 2050s period, and 5.1 to 9.2 percent during the 2080s period. Projected actual ET increases range from 0.7 to 1.4 percent during the 2020s period, 1.3 to 2.1 percent during the 2050s period, and 1.7 to 2.6 percent during the 2080s period. Reference ET is expected to increase significantly more than actual ET due to changes in phenology of annual crops, discussed in the following paragraph.

Projected actual ET estimates assume non-static phenology for annual crops rather than static phenology. With expected increases in temperature across all scenarios, crop growing seasons are expected to be shorter. Non-static phenology is believed to be more accurate as plant growth depends heavily on temperature. This effect is accounted for in non-static phenology by using growing degree days (GDD) to advance the crop coefficient curves across the growing season according to daily temperatures. Consequently, there is less projected impact on actual ET with non-static phenology than when static phenology is assumed. If static crop phenology is assumed, percent changes in actual ET would be similar to the projected changes in reference ET. Reference ET is expected to increase significantly more due to the projected temperature increases.

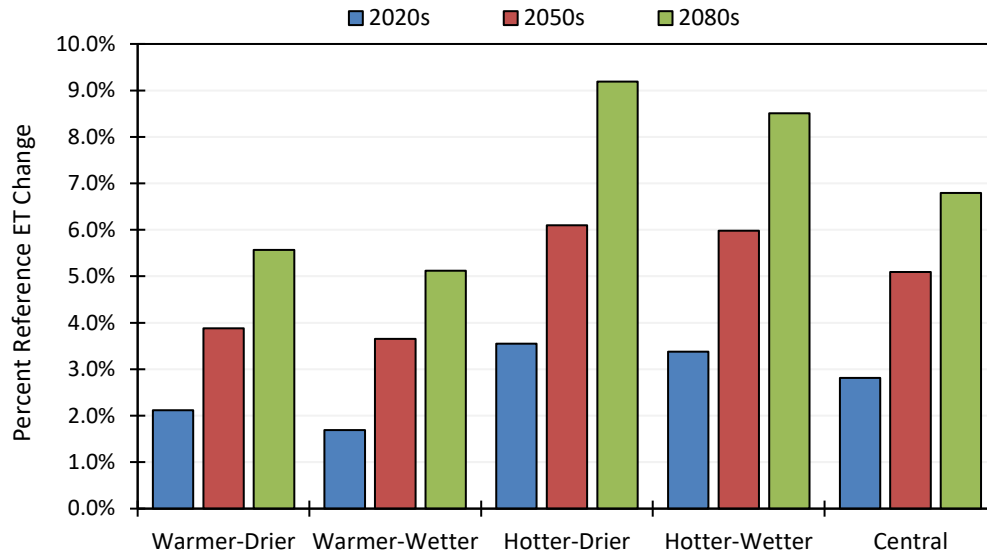

Figure 6-12. WWCRA Projected Reference ET Change.

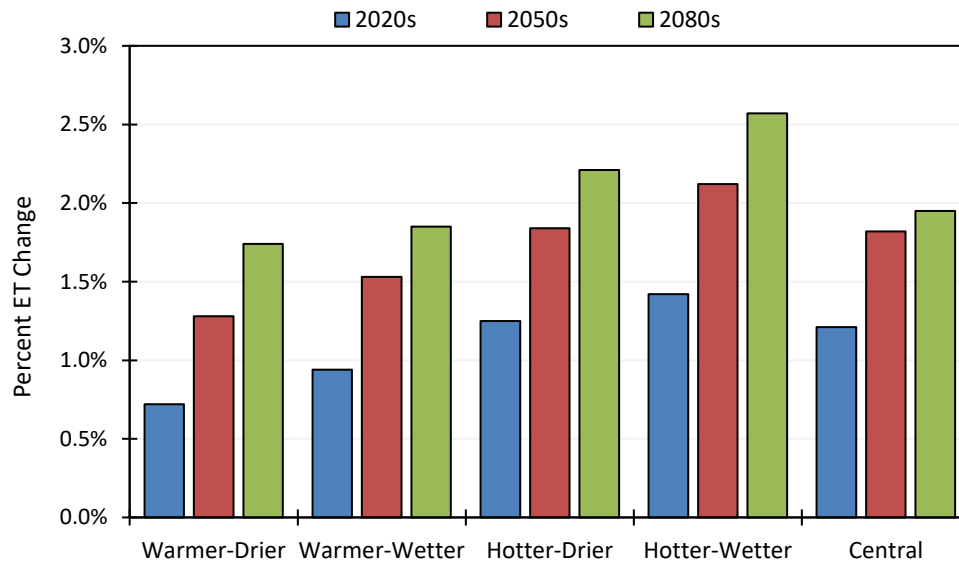

Figure 6-13. WWCRA Projected ET Change Assuming Non-Static Phenology.

6.3 POTENTIAL IMPACTS ON WATER SUPPLY AND QUALITY

The shift in runoff toward the winter period and projected reduction in total runoff have the potential to impact surface water supply in the future if sufficient storage is not available to retain winter runoff until it is needed to meet irrigation demands and to provide additional

carryover storage from wet years to dry years. If New Melones Reservoir is unable to retain increased winter runoff volumes, there is increased probability that the Reservoir's total supply over the course of the irrigation season would be lower than predicted based on an analysis of historical data. However, this is not expected to affect SSJID's annual available supply allotment, which is based on the total annual inflows to New Melones Reservoir under the 1988 Agreement. While the timing of runoff will not affect SSJID's annual allotment, reduced total inflows to New Melones Reservoir in the future would increase the probability that total inflows to the reservoir would be less than 600,000 af in a given year, resulting in supplies less than 300,000 af more often than predicted based on analysis of historical data.

Increased erosion and turbidity under climate change would likely not significantly affect the water quality of the Stanislaus River as it affects agricultural irrigation. Additionally, there are no known contaminants that could be concentrated to levels that would affect agricultural irrigation if spring runoff were to decrease, particularly due to the dilution of such contaminants in reservoirs upstream of the District. Increased water temperature could result in additional challenges to SSJID in controlling aquatic plants in its distribution system to maintain capacity, provided that the temperature increase is significant enough to escalate aquatic plant growth. Increased turbidity and algae growth, if substantial, could pose challenges to filtering SSJID canal water for micro-irrigation.

According to the Eastern San Joaquin Integrated Regional Water Management Plan (ESJ IRWMP 2014) and other sources, climate change is expected to bring more frequent and more severe droughts in the future. With changing rainfall patterns, groundwater basins may experience less recharge in the long term. Groundwater pumping volumes are at their greatest during droughts because there is less surface water to meet water demands. This increases the difficulty of sustainably managing groundwater basins and preventing negative impacts to water quality. As a potential mitigation strategy, SSJID is evaluating opportunities for groundwater recharge and extraction operations that can provide dry year supplies in case of climate change impacts or regulatory induced droughts resulting in more severe droughts.

6.4 POTENTIAL IMPACTS ON WATER DEMAND

As previously discussed, the USBR publication, West-Wide Climate Risk Assessment: Irrigation Demand and Reservoir Evaporation Projections, predicted increased crop ET due to temperature increase and other climate factors (USBR 2015). NIWR is expected to increase for all climate scenarios presented in the USBR report, as shown in Figure 6-14. Additionally, changes in precipitation timing and amounts could result in greater irrigation requirements to meet ET demands. Changes in the timing of crop planting, development, and harvest could also result in changes to the timing of irrigation demands during the year; all impacting the NIWR. Projected NIWR increases range from 1.5 to 3.2 percent during the 2020s period, 1.8 to 4.7 percent during

the 2050s period, and 2.2 to 5.4 percent during the 2080s period. Projected NIWR are based on non-static crop phenology for annual crops.

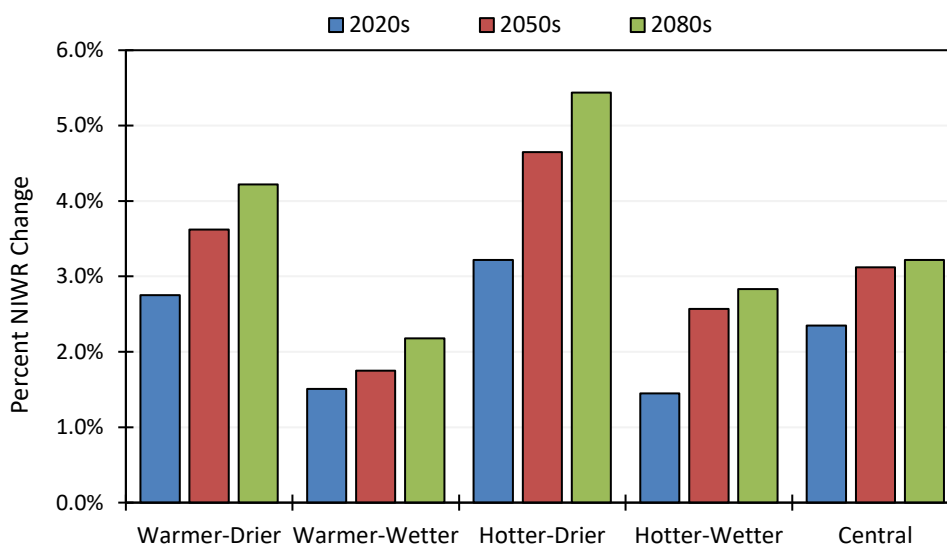

Figure 6-14. WWCRA Projected Net Irrigation Water Requirement Change Assuming Non-Static Phenology.

When interpreting results, several uncertainties must be accounted for. Estimating the effects of CO₂ on irrigation demand requires the use of physiological crop growth models and was not included in the WWCRA. In general, increased atmospheric CO₂ is expected to reduce stomatal conductance and transpiration, which would lead to reduced ET, all else equal. Changes in the types of crop grown, irrigated area, and irrigation efficiencies also affect the amount of irrigation water requirements. For further information, please refer to the West-Wide Climate Risk Assessment: Irrigation Demand and Reservoir Evaporation Projections (USBR 2015).

6.5 POTENTIAL STRATEGIES TO MITIGATE CLIMATE CHANGE IMPACTS

Although there is a growing consensus that climate change is occurring, and many scientists believe the effects of climate change are already being observed, the timing and magnitude of climate change impacts remain uncertain. The District will mitigate climate change impacts with this uncertainty in mind through an adaptive management approach in cooperation with other regional stakeholders, including municipalities within the District, neighboring irrigation districts, and other interested parties. Under adaptive management, key metrics and uncertainties will be identified and monitored (e.g., April – July runoff as a percentage of annual runoff, total runoff, average temperature, and reference evapotranspiration), and strategies will be developed to address the related climate change impacts. As stated, potential impacts occur, the strategies will be prioritized, modified as needed, and implemented.

Several strategies for mitigating climate change impacts to agricultural water providers and other water resources entities have been identified (DWR 2008, CDM 2011). These strategies include those identified as part of the California Water Plan 2009 and 2013 Update (DWR 2010a and 2014) as well as strategies identified as part of the California Climate Adaptation Strategy (CNRA 2009). Many of these strategies applicable to irrigation districts are already being implemented by SSJID in an appropriate form and level to meet local water management objectives. These strategies will continue to serve the District well as climate change impacts occur.

Resource strategies that are being implemented or could be implemented by the District to adapt to climate change are summarized in Table 6-1.

Table 6-1. SSJID Position on Strategies to Mitigate Climate Change Impacts

Source	Strategy	Status
California Water Plan (DWR 2010a, 2013, and 2018a)	Reduce water demand	SSJID is implementing all technically feasible EWMPs identified by SBx7-7 to achieve water use efficiency improvements in SSJID operations and to encourage on-farm improvements. Additional actions to reduce water demand are considered on an ongoing basis as part of SSJID’s water management activities.
	Improve operational efficiency and transfers	As described above and elsewhere in this AWMP, SSJID is implementing improvements to increase operational efficiency within SSJID. Additionally, SSJID is an active participant in the TriDam Project and Authority, the San Joaquin Tributaries Authority, and the San Joaquin River Group, which seek to maximize the efficiency of system operations at the regional scale.
	Increase water supply, including through recharge and sustainable groundwater management	The District has increased its available water supply through conjunctive management of available surface water and groundwater supplies. SSJID recently installed two groundwater wells to supplement surface water supply for the East Basin Reservoir. The District will consider additional opportunities to increase available water supply to compensate for reduced April through July runoff. As a member of the SSJGSA, SSJID is also actively engaged in SGMA-related efforts. Ongoing GSP implementation is guiding sustainable groundwater management in the Eastern San Joaquin Subbasin.
	Improve water quality	SSJID will continue to monitor groundwater and surface water quality internally and through its participation in the San Joaquin and Delta Water Quality Coalition.

Source	Strategy	Status
	Practice resource stewardship	SSJID intrinsically supports the stewardship of agricultural lands within and surrounding its service area through its irrigation operations and resulting groundwater recharge. Additionally, SSJID actively supports protection of ecosystems through its participation in the Stanislaus River Basin Plan, past participation in the Vernalis Adaptive Management Plan (VAMP), and by sustaining riparian habitat coincident with its irrigation and drainage systems.
	Improve flood management	SSJID does not serve a formal flood management role, although its irrigation and drainage systems provide a passive system to collect and convey winter runoff. If runoff characteristics change substantially within SSJID in the future, modifications to the irrigation and/or drainage system to increase capacity or mitigate other impacts may be considered.
	Engage people in water management	SSJID offers affordable surface water in all years, with a tiered volumetric pricing structure that incentivizes surface water use, groundwater recharge (direct and in-lieu), and water conservation. As described in Section 7.4.12, SSJID also offers a variety of agricultural water management educational programs and materials for farmers, staff, and the public.
	Support Long-Term and Regional Water Management Planning	The District collects, manages, and reports a wide array of data related to the District’s operations and water management efforts. The District is also actively involved in regional water management planning and SGMA-related water management planning.
	Other strategies	Other strategies identified in the California Water Plan include crop idling, irrigated land retirement, and rainfed agriculture. Under severely reduced water supplies, SSJID could consider these strategies; however, it is anticipated that climate change impacts will be mitigated through the other strategies described.
California Climate Adaptation Strategy (CNRA 2009)	Aggressively increase water use efficiency	Described above under "Reduced water demand" and "Improve operational efficiency and transfers."
	Practice and promote integrated flood management	Described above under "Improve flood management."
	Enhance and sustain ecosystems	Described above under "Practice resource stewardship."
	Expand water storage and conjunctive management	Described above under "Increase water supply."
	Fix Delta water supply	Not directly applicable to SSJID; however, water transfers could be used to help meet Delta water supply objectives.

Source	Strategy	Status
	Preserve, upgrade, and increase monitoring, data analysis, and management	Through implementation of SSJID's boundary flow measurement program, Irrigation Enhancement Project area water usage and soil moisture monitoring system, SCADA system and other SSJID water management activities, the amount of information and analysis available to support SSJID's water management continues to increase substantially.
	Plan for and adapt to sea level rise	Projections indicate that sea levels could rise by 2 to 5 feet by 2100. Direct impacts on SSJID are not anticipated, although SSJID could consider a role to help mitigate impacts to affected areas through water transfers or other means.
Sacramento and San Joaquin Basins Study (USBR, 2016b)	Reduce water demand	Described above under "Reduce water demand"
	Increase water supply	Described above under "Increase water supply," including through recharge and sustainable groundwater management.
	Improve operational efficiency	Described above under "Improve operational efficiency and transfers." SSJID has and continues to implement improvements to increase operational efficiency through SCADA monitoring and automation, conjunctive use management, and the many other efforts described as EWMPs in Section 7.
	Improve resource stewardship	Described above under "Practice resource stewardship."
	Improve institutional flexibility	Described above under "Improve operational efficiency and transfers."
	Improve data and management	Described above under "Preserve, upgrade, and increase monitoring, data analysis, and management."

6.6 ADDITIONAL RESOURCES FOR WATER RESOURCES PLANNING FOR CLIMATE CHANGE

Much work has been done at state and regional levels to evaluate the effects and impacts of climate change and to develop strategies to manage available water resources effectively under climate change. The following resources provide additional information describing water resources planning for climate change:

6.6.1 Local and Regional Resources

- Eastern San Joaquin Groundwater Subbasin Groundwater Sustainability Plan. Eastern San Joaquin Groundwater Authority. November 2024. Available at: <http://www.esjgroundwater.org/>.

- East Stanislaus Region Integrated Regional Water Management Plan Update. 2018. Available at: <http://www.eaststanirwm.org/>. (ESRIRWMP, 2018)
- San Joaquin Valley Summary Report, Preview. California’s Fourth Climate Change Assessment. 2018. Available at: <https://climateassessment.ca.gov/regions/>.
- Merced Groundwater Subbasin Groundwater Sustainability Plan. Woodard & Curran. November 2019. Available at: <http://www.mercedsgma.org/resources#documents>.

6.6.2 State Resources

- SGMA Climate Change Resources – California Natural Resources Agency (<https://data.cnra.ca.gov/dataset/sgma-climate-change-resources>)
- Progress on Incorporating Climate Change into Planning and Management of California’s Water Resources. California Department of Water Resources. July 2006. (DWR 2006)
- 2009 California Climate Change Adaptation Strategy. California Natural Resources Agency. December 2009. (CNRA, 2009)
- Managing An Uncertain Future: Climate Change Adaptation Strategies for California’s Water. California Department of Water Resources. October 2008. (DWR, 2008)
- Managing an Uncertain Future. California Water Plan Update 2009. Volume 1, Chapter 5. March 2010. (DWR, 2010a)
- Climate Change Characterization and Analysis in California Water Resources Planning Studies. California Department of Water Resources. December 2010. (DWR, 2010b)
- Climate Change Handbook for Regional Water Planning. Prepared for U.S. Environmental Protection Agency and California Department of Water Resources by CDM. November 2011. (CDM, 2011)
- Climate Change and Integrated Regional Water Management in California: A Preliminary Assessment of Regional Perspectives. Department of Environmental Science, Policy and Management. University of California at Berkeley. June 2012. (UCB, 2012)
- California Adaptation Planning Guide: Planning for Adaptive Communities. California Emergency Management Agency and California Natural Resources Agency. July 2012. (Cal EMA and CNRA, 2012)
- Managing an Uncertain Future. California Water Plan Update 2013. Volume 1, Chapter 5. 2013. (DWR, 2013)
- Perspectives and Guidance for Climate Change Analysis. California Department of Water Resources Climate Change Technical Advisory Group. August 2015. (DWR-CCTAG, 2015)
- Actions for Sustainability. California Water Plan Update 2018. Chapter 3. 2018. (DWR, 2018a)
- Safeguarding California Plan: 2018 Update, California’s Climate Adaptation Strategy. California Natural Resources Agency. January 2018. (CNRA, 2018)
- Indicators of Climate Change in California. Office of Environmental Health Hazard Assessment, California Environmental Protection Agency. May 2018. (Cal EPA, 2018)

- Climate Action Plan—Phase 1: Greenhouse Gas Emissions Reduction Plan. California Department of Water Resources. July 2020. (DWR, 2020)
- Climate Action Plan—Phase 2: Climate Change Analysis Guidance. California Department of Water Resources. September 2018. (DWR, 2018b)
- Climate Action Plan—Phase 3: Climate Change Vulnerability Assessment. California Department of Water Resources. February 2019. (DWR, 2019)
- Cal-Adapt website tools, data, and resources for exploring California’s climate change research and developing adaption plans. Available at <https://cal-adapt.org/>.
- Other Resources
- Progress on Incorporating Climate Change into Planning and Management of California’s Water Resources. California Department of Water Resources Technical Memorandum. July 2006. (DWR 2006b)
- Climate Change and Water. Intergovernmental Panel on Climate Change. June 2008. (IPC 2008)
- Managing An Uncertain Future: Climate Change Adaptation Strategies for California’s Water. California Department of Water Resources Report. October 2008. (DWR 2008)
- 2009 California Climate Change Adaptation Strategy. California Natural Resources Agency Report to the Governor. December 2009. (CNRA 2009)
- Climate Change and Water Resources Management: A Federal Perspective. U.S. Geological Survey. (USGS 2009)
- Managing an Uncertain Future. California Water Plan Update 2009. Volume 1, Chapter 5. March 2010. (DWR 2010a)
- Climate Change Characterization and Analysis in California Water Resources Planning Studies. California Department of Water Resources Final Report. December 2010. (DWR 2010b)
- Climate Change Handbook for Regional Water Planning. Prepared for U.S. Environmental Protection Agency and California Department of Water Resources by CDM. November 2011. (CDM 2011)
- Climate Action Plan—Phase 1: Greenhouse Gas Emissions Reduction Plan. California Department of Water Resources. May 2012. (DWR 2012a)
- Climate Change and Integrated Regional Water Management in California: A Preliminary Assessment of Regional Perspectives. Department of Environmental Science, Policy and Management. University of California at Berkeley. June 2012. (UCB 2012)
- Managing an Uncertain Future. California Water Plan Update 2013. Volume 1, Chapter 5. October 2014. (DWR 2014)
- U.S. Bureau of Reclamation (USBR). 2015. West-Wide Climate Risk Assessments: Irrigation Demand and Reservoir Evaporation Projections. Technical Memorandum No. 86-68210-2014-01. Available at <http://www.usbr.gov/watersmart/wcra/index.html>. (USBR 2015)

- 2014 Eastern San Joaquin Integrated Regional Water Management Plan Update. Eastern San Joaquin County Groundwater Basin Authority. June 2014. Available at <http://www.water.ca.gov>. (ESJ IRWMP 2014)
- California Climate Adaption Planning Guide. 2012. California Natural Resources Agency. Available at <http://resources.ca.gov/climate/>.
- Perspectives and Guidance for Climate Change Analysis. August 2015. California Department of Water Resources Climate Change Technical

7 EFFICIENT WATER MANAGEMENT PRACTICES

7.1 OVERVIEW

This section describes the actions that SSJID has taken and is planning to take to accomplish its water management objectives and to improve water use efficiency. These actions are organized with respect to the Efficient Water Management Practices (EWMPs) described in California Water Code §10608.48. The Code lists two types of EWMPs: critical EWMPs that are mandatory for all agricultural water suppliers subject to the Code, and conditional EWMPs that are mandatory if found to be technically feasible and locally cost effective.

The two mandatory, critical EWMPs are (1) measurement of the volume of water delivered to customers with sufficient accuracy for aggregate reporting, and (2) adoption of a pricing structure for water customers based at least in part on the quantity delivered.

SSJID has implemented and plans to continue implementing both critical EWMPs as well as all additional (i.e., conditional) EWMPs that are technically feasible and locally cost effective. Table 7-1 describes each EWMP and summarizes SSJID’s implementation status.

This section describes SSJID’s commitment to efficient water management, beginning with the Water Master Plan study that SSJID funded to explore the possibility of district-wide pressurized irrigation service. Other past, ongoing, and planned efforts to implement the critical and conditional EWMPs are further described in the following subsections.

Table 7-1. Summary of Critical and Conditional EWMPs (Water Code § 10608.48.b and c.)

Water Code Reference No.	EWMP Description	Implementation Status
Critical (i.e., Mandatory) Efficient Water Management Practices		
10608.48.b(1)	Measure the volume of water delivered to customers with sufficient accuracy.	Being Implemented
10608.48.b(2)	Adopt a pricing structure based at least in part on quantity delivered.	Being Implemented
Additional (i.e., Conditional) Efficient Water Management Practices		
10608.48.c(1)	Facilitate alternative land use for lands with exceptionally high water duties or whose irrigation contributes to significant problems, including drainage.	Not Technically Feasible
10608.48.c(2)	Facilitate use of available recycled water that otherwise would not be used beneficially, meets all health and safety criteria, and does not harm crops or soils.	Being Implemented

Water Code Reference No.	EWMP Description	Implementation Status
10608.48.c(3)	Facilitate financing of capital improvements for on-farm irrigation systems.	Being Implemented
10608.48.c(4)	Implement an incentive pricing structure that promotes one or more of the following goals: (A) More efficient water use at farm level, (B) Conjunctive use of groundwater, (C) Appropriate increase of groundwater recharge, (D) Reduction in problem drainage, (E) Improved management of environmental resources, (F) Effective management of all water sources throughout the year by adjusting seasonal pricing structures based on current conditions.	Being Implemented
10608.48.c(5)	Expand line or pipe distribution systems, and construct regulatory reservoirs to increase distribution system flexibility and capacity, decrease maintenance and reduce seepage.	Being Implemented
10608.48.c(6)	Increase flexibility in water ordering by, and delivery to, water customers within operational limits.	Being Implemented
10608.48.c(7)	Construct and operate supplier spill and tailwater recovery systems.	Being Implemented
10608.48.c(8)	Increase planned conjunctive use of surface water and groundwater within the supplier service area.	Being Implemented
10608.48.c(9)	Automate canal control structures.	Being Implemented
10608.48.c(10)	Facilitate or promote customer pump testing and evaluation.	Being Implemented
10608.48.c(11)	Designate a water conservation coordinator who will develop and implement the water management plan and prepare progress report.	Being Implemented
10608.48.c(12)	Provide for the availability of water management services to water users.	Being Implemented
10608.48.c(13)	Evaluate the policies of agencies that provide the supplier with water to identify the potential for institutional changes to allow more flexible water deliveries and storage.	Being Implemented
10608.48.c(14)	Evaluate and improve the efficiencies of the supplier's pumps.	Being Implemented

7.2 WATER MASTER PLAN

Adopted in 2022, the SSJID WMP is a 30-year plan for the District’s agricultural irrigation service and related water distribution facilities. The WMP sets the stage for system enhancements to ensure irrigation service reliability over the next 30 years by addressing aging infrastructure, implementing key modernization projects, and outlining financial strategies to pay

for necessary upgrades. The plan and Capital Infrastructure Program identifies maintenance, rehabilitation and service improvement projects and priorities, including:

- Improved level of service to meet evolving on-farm irrigation needs (flood conversion to sprinkler and drip/micro methods)
- Regulation and recirculation reservoirs to reduce operational spills and equalize service
- Automated flow control devices
- Canyon Tunnel and other upstream water supply improvements
- Variable rates of pipeline and canal replacement and/or rehabilitation
- Trenchless pipeline rehabilitation program

The WMP will be reviewed at regular intervals to evaluate how strategies are being implemented and to update the plan for the next 30 years.

7.3 MANDATORY EWMPs

7.3.1 Delivery Measurement Accuracy (10608.48.b(1))

In recent years, SSJID has made substantial efforts to improve measurement of distribution system flows and farm deliveries to support efficient management of the District's water resources and planning.

As described previously in Section 3.8, SSJID is implementing this EWMP by (1) installing magnetic flow meters to accurately measure deliveries to its customers, (2) installing Acoustic Doppler Flow Meters (ADMs) to facilitate operations so that deliveries would be measured by an ADM or the difference between two ADMs, and (3) completing a Water Master Plan to identify, prioritize, and create a strategic implementation plan for system modernization projects that will support the District's ongoing compliance with SBx7-7.

In the 2012 AWMP, SSJID documented a corrective action plan to comply with the delivery measurement accuracy requirements of §597 of Title 23 of the California Code of Regulations (23 CCR). In 2014, the District embarked on a feasibility study for District-wide pressurized service that, if carried out, would have implemented nearly all the EWMPs and led to SBx7-7 compliance district-wide. During this feasibility study, SSJID temporarily prioritized only those actions in the corrective action plan that would not be wasted if District-wide pressurized service was implemented, continuing to install magnetic flow meters at select delivery points.

Initial feasibility study results indicated that the costs of District-wide pressurization currently outweigh the benefits, so District-wide pressurized service has not been implemented at this

time. However, recognizing the need to accelerate replacement of aging pipelines and improve service to growers, the District has refocused its efforts on its Water Master Plan.

With this aim, SSJID has continued to install magnetic meters that are compatible with potential future modernization projects (e.g. pressurized service). As of 2020, SSJID has installed more than 310 magnetic flow meters, at a cost of approximately \$6,000 each. Of this total, 77 meters are installed in the Irrigation Enhancement Project area and more than 233 meters are installed elsewhere in the system. These meters measure water deliveries to customers with an accuracy conforming to the requirements of SBx7-7. SCADA has been installed on 160 magnetic flow meters (60 magnetic flow meters since 2015) at a cost of approximately \$4,200 each. SSJID's SCADA system transmits water measurement data directly to the District Control Room. SSJID has also installed 42 ADMs along laterals at locations throughout the District.

SSJID's DMs also work with growers to improve delivery flow measurements where magnetic flow meters are pending, infeasible, or exempt (parcels five acres or less and used only for self-consumption). DMs are able to record and log irrigation durations that are used in the District's volumetric delivery measurements. DMs are also able to improve delivery flow measurements using data available in the field. These actions all support SSJID's efforts for compliance with SBx7-7.

Documentation of the District's current agricultural water measurement compliance efforts are provided in Appendix A of this AWMP.

SSJID's efforts to comply with measurement requirements of 23 CCR §597 continue to evolve. In 2024, the District applied for a Water and Energy Efficient Grant under the Bureau of Reclamation's WaterSmart Program to fund an Advanced Metering Infrastructure (AMI) meter replacement program and interactive platform using telemetry to report water meter data to the District. The District also intends to make the data available to growers in near real time. The costs to purchase and install the new water meters and telemetry are estimated to be more than \$4 million with additional ongoing maintenance and replacement costs. The District will update the corrective action plan as needed to achieve timely compliance with the accuracy standards of 23 CCR §597.

7.3.2 Volumetric Pricing (10608.48.b(2))

As described previously in Section 3.9, SSJID has been implementing this EWMP since the District first adopted a volumetric pricing structure on July 31, 2012. In 2023, the District raised its irrigation rates through a successful Proposition 218 effort.

SSJID's current rate structure has two tiers of volumetric pricing for growers that receive non-pressurized water service. For the 2026 irrigation season, a fixed acreage charge of \$60 per acre charge plus an additional volumetric charge. Growers that receive less than 48 inches per year

are charged the ‘Tier 1’ rate, with a volumetric charge of \$10 per af. Growers pay the ‘Tier 2’ rate of \$17.50 per af for any water diverted over 48 inches per year.

Parcels that receive pressurized water from the District’s Division 9 Irrigation Enhancement Project are subject to the fixed acreage charge and volumetric charges plus the Pressurized Irrigation Rate of \$58.12 per acre-foot. The Pressurization rate consists of energy component and provision for capital assets. On January 27, 2026, there was sufficient protests in opposition to the proposed Pressurized Irrigation Rate which is capped at the current rate of \$58.12 per acre-foot until such time as the District holds an additional Proposition 218 process and lawfully approves a proposed rate increase.

For properties that do not partake in District surface water irrigation service and irrigate with groundwater, landowners may qualify to sign-off from District services through a Services Abandonment Agreement. These parcels also would not be subject to the charges and rates above, and instead would pay a groundwater recharge fee of \$12 per acre.

7.4 ADDITIONAL EWMPs

CWC §10608.48.c requires agricultural water suppliers to implement 14 additional EWMPs “if the measures are locally cost effective and technically feasible.” Historically, SSJID has been active in implementing various water management improvements to support the District’s water management objectives. These improvements include water conservation improvements that also increase system efficiency and improve customer delivery service. SSJID is implementing all additional EWMPs with the exception of one that is not technically feasible, as described in the following sections.

7.4.1 Alternative Land Use (10608.48.c(1))

Status: Not Technically Feasible

Facilitating alternative land use, as envisioned through implementation of this EWMP, is not technically feasible in SSJID. This EWMP focuses on resolving problems for lands with exceptionally high water duties or lands where irrigation contributes to significant problems, including problem drainage. Neither of these conditions are found within the District boundaries. Furthermore, SSJID’s Rules and Regulations prohibit wasteful use of water, preventing exceptional water duties or significant problems from occurring (see Section 3.11). Additionally, facilitation of alternative land use is beyond SSJID’s jurisdiction; however, SSJID assists customers in implementing on-farm conservation measures, as described below.

Due to the factors described above, this EWMP is not technically feasible in SSJID, and is not currently being implemented. If, in the future, conditions change such that this is not the case, SSJID will re-evaluate the EWMP implementation.

7.4.2 Recycled Water Use (10608.48.c(2))

Status: Implementing

SSJID is implementing this EWMP by facilitating the safe utilization of available recycled water within its service area. The City of Manteca has provided treated wastewater to irrigated lands within the SSJID service area. The City of Ripon also uses non-potable water for irrigation of city parks and landscaping. The District is also open to evaluating the potential for municipal recycled water as a possible solution to river discharges and as a supplemental irrigation supply source. However, there is currently no known additional available recycled water within the District service area that is not already feasibly beneficially used.

SSJID will continue to work with qualifying permitted dischargers within its service area to gain access to recycled water for agricultural needs.

7.4.3 Capital Improvements for On-Farm Irrigation Systems (10608.48.c(3))

Status: Implementing

SSJID has implemented this EWMP in the past by providing cost shares for capital improvements for on-farm irrigation systems through its On-Farm Water Conservation Program, initiated in 2011. SSJID cost shares totaled approximately \$1.14 million in 2011, providing improvements to 149 different parcels representing 5,350 acres. Six specific water conservation measures were offered through the Program, based on grower interest and District evaluations of implementation costs and cost share percentages (Table 7-2). Over four years, the program provided \$2.8 million in cost share supporting grower investments totaling \$4.1 million on 442 parcels for a total of 17,132 acres (Tables 7-3 and 7-4). An evaluation of the 2011 program prepared in 2012 is included in Appendix C.

The On-Farm Water Conservation Program is currently inactive due to the implementation of the aggressive implementation of the WMP Capital Improvement Program and the lack of discretionary funding. In 2024 and 2025, the District partnered with the San Joaquin Farm Bureau Federation, North San Joaquin Water Conservation District and the Stockton East Water District on a California Department of Food and Agriculture State Water and Energy Efficiency Program (SWEEP) Block Grant to promote direct grower assistance for on-farm improvements. SSJID accepted applications from District growers for projects and selected three projects totaling approximately \$450,000 in direct grower assistance.

Other District actions facilitating on-farm capital improvements include active cooperation with SSJID water users and the Natural Resources Conservation Service (NRCS) to facilitate on-farm improvements through the NRCS Environmental Quality Incentives Program (EQIP) program, as funds are available. The District often supplies technical assistance to facilitate these improvements.

Table 7-2. 2011 On-Farm Water Conservation Program Conservation Measures and Budget

Conservation Measure	District Share (% of Actual Cost)	Cost Share Budget	Max. per Grower
Delivery Measurement	80%	\$190,000	NA (see below)
Sprinkler Conversion	50%	\$168,044	\$25,000
Drip Conversion	50%	\$329,135	\$25,000
Tailwater Recovery	50%	\$178,040	\$25,000
Irrigation Scheduling	75%	\$49,500	\$5,000
Moisture Monitoring	75%	\$45,500	\$5,000
Grower-Proposed Measures	50%	\$179,781	\$25,000
Total: \$1,140,000			
Maximum Combined Payment per Grower: \$50,000			

7.4.4 Incentive Pricing Structures (10608.48.c(4))

Status: Implementing

SSJID is implementing this EWMP by promoting conjunctive use of groundwater by setting water rates below the cost of groundwater pumping to promote the use of available surface water supplies (goals B and C). By maintaining low water rates for surface water relative to groundwater pumping, SSJID is promoting conservation of precious groundwater resources through in-lieu and direct recharge. In addition, the implementation of a volumetric charge per af of water delivered provides a modest incentive to increase water use efficiency at the farm level (goal A). The volumetric charge additionally discourages excessive drainage (goal D).

The District will review and assess its volumetric charge over time to ensure that identified water management objectives are being achieved. Additionally, SSJID's Irrigation Enhancement Project (also known as the Division 9 Project) provides pressurized surface water to growers which incentivizes the installation of more efficient micro and sprinkler irrigation systems and increases groundwater recharge by encouraging growers who were pumping groundwater to now utilize the pressurized surface water. The cost share incentives offered through the District's On-Farm Conservation Program also encourage growers who have filed service abandonment agreements to rejoin the District to become eligible for incentives and utilize surface water in lieu of groundwater.

Table 7-3. General Statistics for 2011 through 2014 On-Farm Water Conservation Program

Year	Parcel Applications Received	Parcels Eligible	Parcels Selected	Measures Implemented	Parcels Receiving Cost Shares		Acres Receiving Cost Shares
					Total	% of Received	
2011	143	141	140	166	138	97%	5,450
2012	160	157	150	177	157	98%	5,520
2013	154	152	148	160	130	84%	5,352
2014	19	19	16	22	17	89%	810
Total:	476	469	454	525	442	93%	17,132

Table 7-4. Cost Share Amounts by Conservation Measure for 2011 through 2014

Conservation Measure	Parcels Receiving Cost Share*	Acres	Implementation Cost			SSJID Cost Share				Grower Cost Share			
			Total	Average	\$/ac	Total	Average	\$/acre	% of Total	Total	Average	\$/acre	% of Total
Delivery Measurement	97	3,597	\$178,394	\$1,839	\$50	\$164,853	\$1,700	\$46	92%	\$13,541	\$140	\$4	8%
Sprinkler or Drip/Micro Conversion	99	3,607	\$4,860,403	\$49,095	\$1,348	\$1,752,474	\$17,702	\$486	36%	\$3,107,929	\$31,393	\$862	64%
Tailwater Recovery	3	228	\$106,978	\$35,659	\$470	\$41,871	\$13,957	\$184	39%	\$65,107	\$21,702	\$286	61%
Irrigation Scheduling	74	3,126	\$285,086	\$3,853	\$91	\$144,929	\$1,959	\$46	51%	\$140,157	\$1,894	\$45	49%
Moisture Monitoring	189	6,373	\$127,846	\$676	\$20	\$94,480	\$500	\$15	74%	\$33,366	\$177	\$5	26%
Grower-Proposed	62	2,133	\$1,346,617	\$21,720	\$631	\$611,213	\$9,858	\$287	45%	\$735,404	\$11,861	\$345	55%
Total:			\$6,905,324			\$2,809,820			41%	\$4,095,504			59%

Intentionally Left Blank

7.4.5 Lining or Piping of Distribution System and Construction of Regulating Reservoirs (10608.48.c(5))

Status: Implementing

SSJID is implementing this EWMP through its efforts to line canals, install pipelines across the majority of the distribution system, and to construct three regulating reservoirs throughout the District, in addition to other District reservoirs constructed primarily for storage, but that also provide some flow regulation benefits. These efforts are described in the subsections below.

7.4.5.1 Lining of Piping Distribution System

The SSJID distribution system consists of 38 miles of concrete-lined canals and 312 miles of pipelines, with the exception of the 18 mile long Main Distribution Canal, which remains unlined to provide beneficial groundwater recharge through seepage. SSJID began lining earthen ditches and converting to pipelines in the 1960s when they replaced 210 miles of open, earthen ditches with buried pipelines.

SSJID maintains its distribution system on a continuous basis, including replacement of canal lining and pipelines as they reach the end of their useful life. SSJID has also installed multiple pipeline interties on dead end lateral pipelines to increase delivery flexibility and reduce losses, especially for pumped irrigation deliveries. Lines that are impacted by development require the developer to replace pipes.

With the adoption of the WMP in 2022, the District invested in trenchless pipe relining technology to extend the useful life of aging cast in place concrete pipe. The District purchased, rented, or retrofitted concrete pumps, water trucks, vacuum-trucks, and other equipment to accomplish a target relining rate of 21,000 LF per year. For the 2025-2026 Maintenance Season, SSJID completed approximately 15,500 LF of pipe relining. The current fully-loaded cost is approximately \$90 per LF which is far less expensive than the cost for a full reinforced concrete pipe replacement.

7.4.5.2 Constructing Regulating Reservoirs

SSJID has also constructed three regulating reservoirs within its service area. In 1992, the Van Groningen Reservoir was constructed near the terminus of the MDC to provide 60 acre-feet of storage to capture excess canal inflows flows for re-regulation. The reservoir capacity was increased to 125 acre-feet in 2002. Due to the construction of the reservoir and automation of the MSC and MDC below Woodward Reservoir, SSJID has essentially eliminated spillage from the MDC.

In 2003, SSJID constructed the five-acre Northwest Regulating Reservoir and a cross-lateral intertie pipeline between the Q and R laterals as part of the System Improvements for Distribution Efficiency (SIDE) project in an effort to increase supply flexibility and absorb excess flows for redistribution and spillage reduction.

SSJID completed the construction of the Irrigation Enhancement Project (also known as the Division 9 Project) in 2012, providing pressurized surface water to a current total of 77 customers (as of 2020) through 19 miles of buried PVC pipeline. Five additional customers have connected to the system since 2015. The project includes the seven-acre East Basin reservoir that buffers supply for the project and captures operational spillage from the V, U and W laterals for re-regulation and distribution. Future expansion of the pressurized system includes the possible addition of a second seven-acre West Basin regulating reservoir on the west side of the Irrigation Enhancement Project area. The construction of this basin will depend on the future findings of SSJID's Water Master Plan. The Irrigation Enhancement Project service area maintains the old low-head pipelines and open canals for flood irrigation deliveries and supplies pressurized water through the new PVC pipe network. This greatly increases flexibility and distribution efficiency both for micro- and sprinkler-irrigation and for surface irrigation.

The SSJID identified and evaluated specific regulating reservoir projects located in strategic locations in SSJID's distribution system. One project, the Q-Qc Reservoir Project, has been identified for its ability to be located in an area where conveyance crop demands out pace conveyance capacity. The District sought a Bureau of Reclamation WaterSmart Drought Response Grant Program asking for \$2 Million of the \$4.72 Million Project.

7.4.6 Increased Water Ordering and Delivery Flexibility (10608.48.c(6))

Status: Implementing

The District is implementing this EWMP by maximizing the amount of flexibility in water ordering by, and delivery to, water customers within operational limits. In particular, SSJID works with customers on an ongoing basis to facilitate deliveries to pump customers using pressurized irrigation systems. The widespread conversion from flood irrigation to pressurized irrigation in SSJID has drastically changed the way the District delivers water, as growers increasingly require precise, high frequency, and low volume deliveries for extended durations. The use of these systems has increased over time and is anticipated to continue to increase in the future.

The Irrigation Enhancement Project (also known as the Division 9 Project) was completed in 2012 and provides pressurized water on an arranged demand basis to a current total of 77 customers within SSJID's service area (as of 2020). Five additional customers have connected to the system since 2015. Construction of the Irrigation Enhancement Project retained the original non-pressurized delivery infrastructure to supply flood irrigators. The dual system allows increased flexibility for both pressurized and flood irrigators by effectively increasing overall system capacity and providing a dual system that can cater to the distinct irrigation needs of the two different irrigation system types. Growers are able to order water through the Internet using personal computers or mobile devices and can check the status of water deliveries, past water orders, and delivery flow rates.

The On-Farm Conservation Program (active from 2011 to 2014) strengthened communications between irrigation customers and SSJID and helped identify the potential for further operational improvements to provide even greater levels of delivery flexibility and steadiness.

Construction of the Northwest, Van Groningen, and East Basin regulating reservoirs and intertie pipelines have greatly increased flexibility, especially to growers near the lower ends of the system that typically receive the largest fluctuations in delivery steadiness. SSJID has considered the possible addition of a second seven-acre West Basin regulating reservoir on the west side of the Irrigation Enhancement Project area, though the construction of this basin will depend on the future findings of SSJID's Water Master Plan.

During the late 1980s and early 1990s, SCADA was installed at all MDC drop structures and all lateral headings, with automation of many of the MDC control and lateral delivery structures. These upgrades have increased the accuracy of deliveries to laterals, reduced measurement and gate adjustment effort required by the DMs, and increased monitoring and data collection for quality control and planning purposes. MDC control, combined with SCADA installations at boundary outflow sites, has provided valuable information and control to increase water ordering and delivery flexibility while controlling operational spillage.

SSJID implemented TruePoint water ordering software in 2010 to allow DMs to better track and manage water orders and to create permanent and consistent records of water usage. The streamlined recording process increases water ordering efficiency and allows additional customer ordering flexibility.

In 2020, SSJID prepared a conceptual plan to modernize the District's Water Information System (WIS). In its current form, SSJID's WIS encompasses all systems that are used to collect, store, analyze, and share data related to all aspects of water supply, water deliveries, water management planning, water budget development, and other reporting needs in SSJID. However, these systems are generally not integrated and new demands for water-related data require that SSJID be able to assemble data in long-term (multi-year) time series with greater accuracy and increased spatial and temporal resolution. Modernization of SSJID's WIS will make it easier to meet these new demands, while also supporting the District's ability to actively monitor the distribution system, allowing DMs to manage and deliver water supplies to customers with greater flexibility. The District plans to modernize its WIS in the coming years.

SSJID continues to modify pour-over walls (weirs) in pipeline control box structures, with the goal of improving delivery flexibility to customers that increasingly use sprinkler and low-flow irrigation systems. Pour-over walls were previously installed to provide sufficient upstream pressure for flood irrigation, but are generally unnecessary for, and an impediment to, sprinkler irrigation. These modifications will also give additional flexibility to Division managers in operating the system, while reducing the pressure on existing laterals and extending their usable life.

SSJID has also installed float valves along several laterals throughout the District. Float valves are a cost-effective means of automatically regulating flow and maintaining constant pressure along laterals that serve irrigators with variable demand (e.g., irrigators with sprinkler and low-flow irrigation systems), particularly along “dead-end” laterals. The District has installed many of these valves in series with automated gates and remote water level sensors, allowing DMs to maintain multiple segments of pipeline in downstream level control at various water level elevations for each reach. These installations allow SSJID to deliver water to customers with greater precision, lower effort, and lower stress on the District’s aging infrastructure. SSJID budgets for installations of these setups across the District based on available funds and interest from growers to connect or reconnect to SSJID’s system for high-efficiency service.

In the future, SSJID will continue to evaluate and implement locally cost-effective actions to further increase the flexibility and steadiness of irrigation deliveries.

7.4.7 Supplier Spill and Tailwater Recovery Systems (10608.48.c(7))

Status: Implementing

SSJID is implementing this EWMP through the operation of regulating reservoirs to capture and prevent spillage, through monitoring of spillage and boundary outflows, and through automation of the MDC and lateral headings to prevent spillage.

The Van Groningen Reservoir collects and stores potential spillage as it provides for re-regulation of MDC outflows. Implementation of SCADA monitoring and control capabilities at drop structures and lateral headings along the MDC has also helped to reduce potential spillage. Automation of the MDC provides SSJID operators with the real-time water levels and water travel times needed to anticipate and eliminate operational spillage. The East Basin in the Irrigation Enhancement Project area was designed and is operated to capture spillage from nearby laterals. The collection and utilization of operational spillage also occurs between Divisions 2 and 3 where the Campbell Drain collects operational spillage and tailwater and conveys it into the "B" lateral in Division 3 for reuse. SSJID has considered the possible addition of a second seven-acre West Basin regulating reservoir on the west side of the Irrigation Enhancement Project area, which would further support spillage capture. However, the construction of this basin will depend on the future findings of SSJID’s Water Master Plan.

In efforts to provide sufficient water to pump irrigators on “dead end” laterals, SSJID supplies the growers with slightly more water than required to prevent any occurrences of pump cavitation or pump shutdown due to low water levels. Pump irrigators are billed for this additional water and, in the case of dead end lines, typically discharge this excess water onto their fields, resulting in tailwater, or discharge this water directly into drains. Installation of intertie pipelines on dead end laterals has eliminated this requirement, thus reducing spillage and tailwater.

Tailwater production within SSJID is generally limited due to the level basin irrigation practices typically employed for surface irrigation and the expanding use of pressurized irrigation systems. Where tailwater drains do not exist, and when determined that irrigation and agronomic practices do not jeopardize water quality, SSJID allows growers to channel tailwater back into District pipelines. SSJID is increasing its real time monitoring of operational spillage as part of its customer delivery measurement program and plans to evaluate additional opportunities to reduce spillage once more information becomes available District-wide. The upper portions of the lower MSC and MDC (upstream of Drop 3) have 36 spill locations that receive tailwater and operational spillage from surrounding fields (mainly pasture) and OID for redistribution.

SSJID continues to evaluate and implement locally cost-effective actions to further increase the prevention, recovery, and reuse of operational spillage and tailwater.

7.4.8 Increase Planned Conjunctive Use (10608.48.c(8))

Status: Implementing

The District is implementing increased, planned conjunctive use by encouraging the use of available surface water supplies, when available, in lieu of groundwater by facilitating delivery service to customers using pressurized irrigation systems and by providing surface water at a lower cost than that of pumping groundwater. These actions conserve groundwater for pumping in years of limited surface water availability and by neighboring water users such as the cities of Manteca, Lathrop, Ripon, and Escalon.

Since 2005, SSJID has also delivered surface water supplies to the Nick C. DeGroot Water Treatment Plant (WTP), where it is treated and used to supply municipal water demands as part of the South County Water Supply Program (SCWSP). The SCWSP was developed through a collaborative and cooperative effort of the SSJID, and the Cities of Manteca, Escalon, Lathrop, and Tracy to provide treated surface water to supplement the water supplies of the cities, some of which were entirely dependent on groundwater. Since it was commissioned in 2005, approximately 17,000 af has been delivered each year from Woodward Reservoir to the WTP for treatment and delivery to the cities currently under contract. SSJID's support has increased conjunctive use of surface water and groundwater in these urban areas within and surrounding the District's service area.

SSJID also maintains more than 20 groundwater wells and pumps in the western portion of the District to control shallow groundwater levels and to provide a supplemental water supply during dry years. Additionally, SSJID recently completed its Irrigation Enhancement Project (also known as the Division 9 Project) which provides pressurized surface water for irrigation to a current total of 76 customers through 19 miles of pipelines. Five additional customers have connected to the system since 2015. Many of the parcels within the Irrigation Enhancement Project that were previously irrigated exclusively with groundwater have connected to the

pressurized surface water, supporting increased conjunctive use. In the last five years, the District drilled two additional groundwater wells to supply the East Basin to supplement the water supply available to the project area. Each well is screened at different depths to withdraw water from two different aquifer layers.

As a member of the SSJGSA, SSJID has actively participated in the development, adoption, and implementation of the 2020, 2020 Revised, and 2024 Amended Eastern San Joaquin Subbasin GSPs. The 2024 amended GSP identifies the actions needed to achieve groundwater sustainability in the Eastern San Joaquin Subbasin, providing support for ongoing conjunctive use of surface water and groundwater supplies in the Subbasin. Deep percolation of applied surface water in SSJID and seepage from SSJID's canals and reservoirs are a critical source of groundwater recharge to maintain a sustainable groundwater supply for users within SSJID. SSJID through the SSJGSA anticipates needing to refine how groundwater recharge and pumping is accounted or so that conjunctive use management actions come on-line, the GGSA responsible for the benefits can be properly credited. The SSJGSA and other GSA in Eastern San Joaquin are investing in methods that track evapotranspiration using satellite imagery and support an annual accounting based on the method. SSJID through the SSJGSA will continue to support GSP implementation, GSP reporting (annual reports and periodic five-year reviews), groundwater monitoring, and other efforts.

7.4.9 Automate Canal Control Structures (10608.48.c(9))

Status: Implementing

SSJID is implementing this EWMP through the automation of all 24 of its lateral headings and all control structures on the MSC and MDC, which improves customer service while reducing losses. SSJID operates a mix of Rubicon gates, AquaSystems2000 LOPAC® gates, downstream water level sensors, and SonTek IQ devices that support MDC automation.

The SIDE reservoir is also automated to maintain water supply to three of the adjacent laterals during deliveries. SSJID's extensive SCADA system provides communication and monitoring of all automated sites and also provides remote control of all groundwater wells operated by the District. Additionally, the Irrigation Enhancement Project resulted in automation of 19 miles of pipelines and deliveries to 77 customers farming about 3,800 acres. In the future, SSJID will continue to evaluate and, when locally cost-effective, implement opportunities for additional automation to increase delivery flexibility and steadiness while reducing operational spillage.

SSJID has installed, or plans to install, float valves along several laterals throughout the District. Float valves are a cost-effective means of automatically regulating flow and maintaining constant pressure along laterals that serve irrigators with variable demand (e.g., irrigators with sprinkler and low-flow irrigation systems). Float valves also require little annual maintenance and do not rely on electronics to operate. SSJID recognizes the value of float valves as a simple solution for providing service to irrigators who are currently on groundwater or would like to convert to a micro-irrigation method and continues to plan and budget for installation of float valves across the District where feasible.

SSJID has also budgeted nearly \$900,000 through 2021 to install 16 new automated gates at various locations throughout the District. Several new Rubicon SlipMeters or BladeMeters are planned to provide automated flow control on dead-end pipelines or laterals with downstream sprinkler customers, where precise flow control and adjustment are extremely difficult for Division Managers. In early 2021, SSJID installed one meter at the Valley Home Drop just downstream of the Van Groningen Reservoir. Others would be installed at locations where flow is divided between laterals, supporting measurement in addition to the benefits of canal automation. Many of the automated gates will be integrated with downstream remote water level sensors and float valves to optimize control. This arrangement allows SSJID to maintain multiple segments of pipeline in downstream level control, with various water level elevations for each reach. In the past, unnecessary pressures resulting from sprinkler deliveries caused many pipelines to need replacement. In many cases, the life of these types of pipelines can be substantially extended if pressure is reduced.

In 2021, SSJID started upgrades and replacement of aging SCADA and automation infrastructure on the MDC. Planned upgrades include installation of a programmable logic controller (PLC), upgrades to radio and power components, and new gate designs.

7.4.10 Facilitate Pump Testing (10608.48.c(10))

SSJID is implementing this EWMP by facilitating and promoting customer pump testing and evaluation. SSJID has provided links on its website to programs that provide these services, such as the Advanced Pumping Efficiency Program available through Pacific Gas and Electric Company's (PG&E) Customer Energy Efficiency offerings (<http://www.pumpefficiency.org/>). In the past, SSJID has considered cost sharing for pump efficiency testing as part of its On-Farm Water Conservation Program. While this program is currently suspended, SSJID may consider cost sharing in the future if the program is reinstated.

7.4.11 Designate Water Conservation Coordinator (10608.48.c(11))

SSJID is implementing this EWMP by continuing to designate a Water Conservation Coordinator to develop and implement the District's agricultural water management plan. SSJID added a permanent, full-time Water Conservation Coordinator position in 2011.

7.4.12 Provide for Availability of Water Management Services (10608.48.c(12))

SSJID is implementing this EWMP through a number of services aimed at supporting customers' water use efficiency and management.

SSJID provides for the availability of irrigation scheduling and crop evapotranspiration information by providing a link to local weather forecasts, the California Irrigation Management Information System (CIMIS), and other water management resources to growers on the District's website (Figure 7-1). SSJID plans to continue providing links to CIMIS and other water management information on its website.

In the past, SSJID also provided for the availability of water management services through its On-Farm Water Conservation Program, including scientific irrigation scheduling and soil moisture monitoring conservation measures.

Water usage is reported to all growers as part of implementing the District's volumetric water charge, which began in 2013. SSJID has offered online account access to growers since 2013. Historical water use data is available to growers in the Irrigation Enhancement Project through an internet-based portal. SSJID is in the process of installing SCADA equipment on all farm meters in the District, with the goal of achieving real-time monitoring and tracking of all deliveries. The District has added SCADA to a total of 160 magnetic flow meters since the beginning of 2015. Delivery data are available to growers through the District's on-farm meter portal. The portal has been available since 2018.

SSJID periodically produces its “Irrigation Newsletter” (Figure 7-2), with information for growers about the irrigation season, proposed projects, updates regarding District planning efforts, and educational opportunities.

SSJID also provides educational materials and resources to farmers, staff, and the public through the District’s website. The District’s “Agriculture / Irrigation Water” webpage (<https://www.ssjid.com/district-services/agriculture-irrigation-water/>) provides growers with information about water management, SBx7-7 compliance efforts, and water conservation. This webpage also provides growers with a link to the District’s most recent AWMP. The “News” webpage (<https://www.ssjid.com/news/>) contains links to official publications, press releases, and information about various ongoing District projects. The “Education” webpages (for example, <https://www.ssjid.com/education/for-teachers/>) also contain resources for children and teachers that discuss water safety, the importance of water for the community and for agriculture, and topics related to water conservation and hydropower.

7.4.13 Evaluate Supplier Policies to Allow More Flexible Deliveries and Storage (10608.48.c(13))

SSJID is implementing this EWMP through ongoing cooperation and discussion with USBR and other agencies that affect SSJID’s flexibility in delivering and storing water. Although SSJID owns its own surface water rights, SSJID actively evaluates the effect of USBR and Tri-Dam Project policies and operational practices on District operations and seeks policy changes to alleviate water supply constraints.

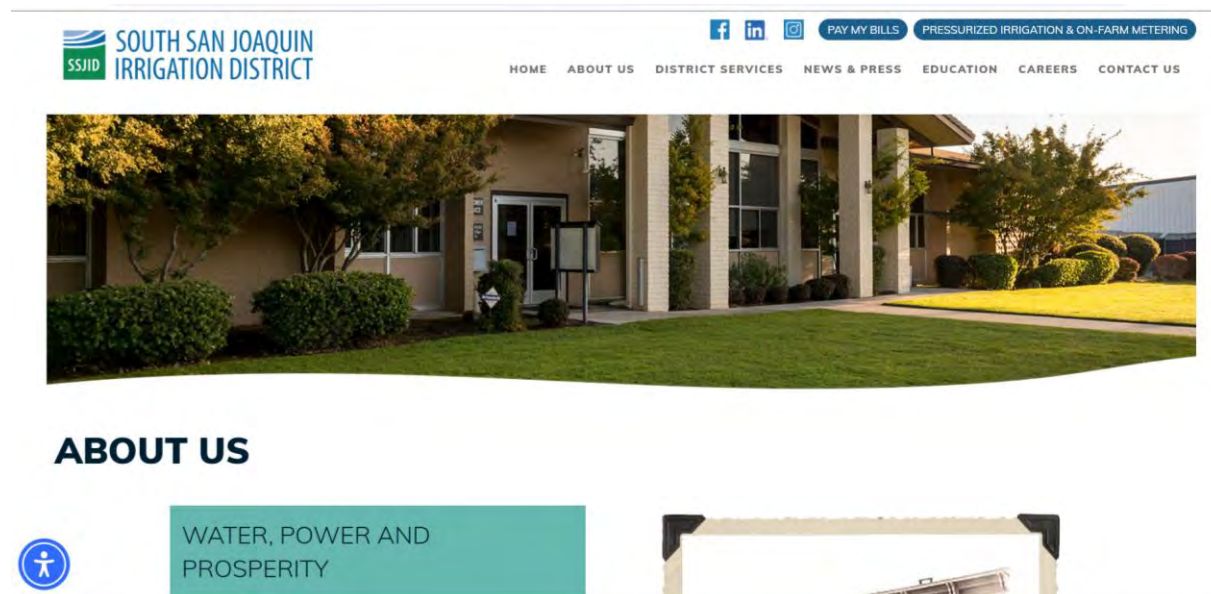

Figure 7-1. SSJID Website



Figure 7-2. SSJID Irrigation Newsletter (Winter 2025, Page 1).

SSJID actively participates in initiatives that affect its water users, including the process to implement the Water Conservation Act of 2009 (SBx7-7). An example of this coordination is SSJID's role in the formation and ongoing operation of the South San Joaquin Groundwater Sustainability Agency (SSJGSA), an association formed between SSJID and the Cities of Ripon and Escalon. As a member of the SSJGSA, SSJID is actively involved in GSP-implementation

efforts for the Eastern San Joaquin Subbasin, which may affect the flexibility of water use and storage in the Subbasin.

SSJID will continue to participate in local, regional, and statewide water management initiatives that affect the District's ability to store and deliver water to ensure that SSJID is able to meet irrigation and other demands with the degree of flexibility required to maintain and enhance efficient water management.

7.4.14 Evaluate and Improve Efficiencies of Supplier's Pumps (10608.48.c(14))

SSJID is implementing this EWMP by evaluating and improving the efficiency of its pumps. The District performs periodic pump efficiency tests to identify cost effective energy and/or water conservation improvements. In addition to the District's groundwater wells, SSJID maintains seven pumps at the Sam Bologna Reservoir and five pumps at the SIDE Reservoir. As a direct result of these monitoring efforts, SSJID has identified a deep well that is performing at 30 percent efficiency, and has planned and budgeted to rebuild this well in 2021.

SSJID will continue evaluating and improving the efficiencies of its pumps at a locally-cost effective level.

7.5 SUMMARY OF EWMP IMPLEMENTATION STATUS

SSJID has taken many actions to promote efficient water management throughout its more than 110 year history. Today, SSJID continues to evaluate and implement additional measures to accomplish improved and more efficient water management, according to the District's water management objectives. For purposes of this AWMP, SSJID water management actions have been organized and are reported with respect to the Efficient Water Management Practices (EWMPs) listed in CWC §10608.48. A summary of the implementation status of each listed EWMP has been provided previously in Table 7-1. A summary of specific current and planned activities related to each EWMP is provided in Table 7-5.

Table 7-5. Summary of EWMP Implementation Status

Water Code Reference No.	EWMP	Position	Implemented Activities	Planned Activities
Critical (Mandatory) Efficient Water Management Practices				
10608.48.b(1)	Measure the volume of water delivered to customers with sufficient accuracy	Being Implemented	<p>As of 2024, more than 310 magnetic flow meters have been installed in SSJID, including 77 meters in the Irrigation Enhancement Project area and more than 233 meters installed elsewhere in the system. Outside of the Irrigation Enhancement Project area, farm deliveries without magnetic meters are currently measured by rated gates or, in some cases, by determining the difference in flow between stand structures in the lateral upstream and downstream of the farm turnout.</p> <p>In 2024, the District applied for a Water and Energy Efficient Grant under the Bureau of Reclamation’s WaterSmart Program to fund an Advanced Metering Infrastructure (AMI) meter replacement program and interactive platform using telemetry to report water meter data to the District. The District also intends to make the data available to growers in near real time. The costs to purchase and install the new water meters and telemetry are estimated to be more than \$4 million with additional ongoing maintenance and replacement costs. District will update the corrective action plan as needed to achieve timely compliance with the accuracy standards of 23 CCR §597.</p>	
10608.48.b(2)	Adopt a pricing structure based at least in part on quantity delivered	Being Implemented	<p>In 2023, the District raised its irrigation rates through a successful Proposition 218 effort. SSJID’s current rate structure has two tiers of volumetric pricing for growers that receive non-pressurized water service. For the 2026 irrigation season, a fixed acreage charge of \$60 per acre charge plus an additional volumetric charge. Growers that receive less than 48 inches per year are charged the ‘Tier 1’ rate, with a volumetric charge of \$10 per af. Growers pay the ‘Tier 2’ rate of \$17.50 per af for any water diverted over 48 inches per year.</p> <p>Parcels that receive pressurized water from the District’s Division 9 Irrigation Enhancement Project are subject to the fixed acreage charge and volumetric charges plus the Pressurized Irrigation Rate of \$58.12 per acre-foot..</p>	
Additional (Conditional) Efficient Water Management Practices				
10608.48.c(1)	Facilitate alternative land use for lands with exceptionally high water duties or whose irrigation contributes to significant problems, including drainage.	Not Technically Feasible	<p>"Lands with exceptionally high water duties or whose irrigation contributes to significant problems" are not known to exist within the SSJID service area. District Rule #10 in the rules and regulations governing the distribution of water within SSJID prohibit the wasteful use of water through the "...flood[ing] of certain portions of the land to an unreasonable depth or amount." Additionally, facilitation of alternative land use is beyond SSJID's jurisdiction; however, SSJID assists customers in implementing on-farm conservation measures, as described under EWMP 4.</p>	
10608.48.c(2)	Facilitate use of available recycled water that otherwise would not be used beneficially, meets all health and safety criteria, and does not harm crops or soils	Being Implemented	<ol style="list-style-type: none"> 1. M&I wastewater from City of Manteca applied directly to SSJID irrigated lands. 2. No additional available recycled water exists within the District service area that is not already feasibly beneficially used. 3. Ripon currently uses recycled water for irrigation of city parks and landscaping. 	<ol style="list-style-type: none"> 1. Continue existing use of recycled water within SSJID. 2. Consider requests from all qualifying permitted dischargers for additional use of recycled water.
10608.48.c(3)	Facilitate financing of capital improvements for on-farm irrigation systems	Being Implemented	<ol style="list-style-type: none"> 1. The District has suspended its On-farm Program. 2. The District is implementing an aggressive CIP since adoption of the SSJID WMP in 2022. 	<ol style="list-style-type: none"> 1. Continue facilitating and supporting on-farm improvements through SWEEP Grant Program as funds are available 2. Potentially continue the On-Farm Conservation Program as soon as funds become available.

Water Code Reference No.	EWMP	Position	Implemented Activities	Planned Activities
10608.48.c(4)	Implement an incentive pricing structure that promotes one or more of the following goals: (A) More efficient water use at farm level, (B) Conjunctive use of groundwater, (C) Appropriate increase of groundwater recharge, (D) Reduction in problem drainage, (E) Improved management of environmental resources, (F) Effective management of all water sources throughout the year by adjusting seasonal pricing structures based on current conditions.	Being Implemented	<ol style="list-style-type: none"> 1. SSJID’s volumetric charge promotes more efficient water use at the farm level and discourages excessive drainage (goals A and D). 2. Current pricing maintains low rates for surface water to promote conservation of groundwater through in lieu and direct recharge (goals B and C). 3. SSJID’s Irrigation Enhancement Project incentivizes more efficient irrigation systems and increases groundwater recharge in lieu and direct recharge (goals A through D). 4. Conservation Program increases use of surface water and efficient irrigation practices by encouraging growers who aren’t District members to join to become eligible for incentives (goals A through D). 	<ol style="list-style-type: none"> 1. The District will review and assess its volumetric charge over time to ensure that identified water management objectives are being achieved.
10608.48.c(5)	Expand line or pipe distribution systems, and construct regulatory reservoirs to increase distribution system flexibility and capacity, decrease maintenance and reduce seepage	Being Implemented	<ol style="list-style-type: none"> 1. Main Canal is mostly unlined but provides beneficial groundwater recharge through seepage. 2. Maintain 312 miles of pipeline. 3. Maintain 38 miles of lined channel. 4. Maintain 18 miles of unlined channel. 5. Scheduled maintenance and/or replacement of infrastructure. 6. Constructed Van Groningen Reservoir in 1992. 7. Constructed 5-acre SIDE reservoir and cross-lateral intertie pipeline in 2003. 8. Constructed 7-acre Sam Bologna Reservoir as part of the Irrigation Enhancement Project (also known as the Division 9 Project), completed in 2012. 9. Replaced approximately 5.8 miles of old pipeline between 2015 and 2020. 10. Reline (shotcrete) 3,000 to 4,000 LF of ditch per year. 11. Initiated trenchless pipe lining program with a target lining rate of 21,000 LF per year. In 2025-2026, SSJID crews accomplished 15,500 LF of pipe relining at a cost of ~\$90 per LF. 	<ol style="list-style-type: none"> 1. Strive to reach 24,000 LF per year Pipe Relining target. 2. Continue Maintenance Program. 3. Seek grant funding for Q-Qc Reservoir Project.

Water Code Reference No.	EWMP	Position	Implemented Activities	Planned Activities
10608.48.c(6)	Increase flexibility in water ordering by, and delivery to, water customers within operational limits	Being Implemented	<ol style="list-style-type: none"> 1. Ongoing efforts to facilitate high frequency, low volume deliveries to pump customers using pressurized irrigation systems. 2. Irrigation Enhancement Project (also known as the Division 9 project) completed in 2012 provides pressurized water on an arranged demand basis to a current total of 77 customers (as of 2020) while also enhancing delivery service for remaining surface irrigators. 3. On-Farm Conservation Program helped improve District-grower coordination. 4. Canal automation and construction of regulating reservoirs and intertie pipelines enhances flexibility and steadiness, especially to growers near the lower ends of the system. 5. Implementation of SCADA and TruePoint enhances DMs' ability to track and manage flows through the distribution system and deliveries to customers, improving delivery efficiency and flexibility 6. Conceptual plan to modernize the District's Water Information System (WIS) completed in 2020, will also improve the District's ability to efficiently track and manage flows and deliveries 7. Infrastructure improvements to enhance delivery flexibility to customers, especially those using sprinkler and microirrigation systems and those served along "dead-end" laterals: <ol style="list-style-type: none"> a. Pour-over wall (weir) modifications in pipeline control box structures. b. Float valve, automated gates, and remote water level sensor installations for automatic flow regulation and downstream level control. 	<ol style="list-style-type: none"> 1. Improve the level of service consistent with the SSJID WMP. 3. Evaluate continued funding of On-Farm Conservation Program on a year-to-year basis. 4. Seek grant for Advanced Metering Infrastructure 5. Continue infrastructure improvements to enhance delivery flexibility to customers, especially those using sprinkler and microirrigation systems and those served along "dead-end" laterals: <ol style="list-style-type: none"> a. additional pour-over wall (weir) modifications b. additional float valve, automated gates, and remote water level sensor installations 6. Evaluate and implement additional locally cost-effective actions to improve flexibility
10608.48.c(7)	Construct and operate supplier spill and tailwater recovery systems	Being Implemented	<ol style="list-style-type: none"> 1. SCADA at all drop structures along the MDC provides real-time control to prevent spillage. 2. The Van Groningen Reservoir provides for collection and storage of spillage and re-regulation. 3. The East Basin Reservoir in the Irrigation Enhancement Project area captures spillage nearby divisions. 4. Campbell Drain (Division 2) collects operational spillage and tailwater and conveys it into the "B" lateral in Division 3 for reuse. 5. Where tailwater drains do not exist, growers may channel tailwater back into District pipelines for redistribution. 6. Intertie pipeline construction for redistribution of excess. 7. Accept tailwater at 36 locations along the upper portions of the MSC and MDC, including spillage and tailwater outflows from OID 8. Continued and expanded monitoring at spill sites to reduce spillage and develop representative data. 	<ol style="list-style-type: none"> 1. Rehabilitate and replace all drain monitoring sites to reduce spillage and develop representative data. 2. Install flow meter at FCOC to measure water leaving the system. 3. Find grant funding for identified WMP opportunities to expand tailwater and spillage prevention and recovery capabilities.

Intentionally Left	EWMP	Position	Implemented Activities	Planned Activities
10608.48.c(8)	Increase planned conjunctive use of surface water and groundwater within the supplier service area	Being Implemented	1. Encourage use of available surface water supplies in lieu of groundwater through construction of pressurized irrigation systems. 2. Provide surface water at a lower cost than that of pumping groundwater. 3. Utilize more than 20 groundwater wells to augment surface water supplies and control shallow groundwater levels. 4. Constructed Irrigation Enhancement Project to provide pressurized surface water for irrigation to a current total of 77 customers (as of 2020) through 19 miles of pipelines serving approximately 3,800 acres. 5. Ongoing deliveries of surface water to the Nick D. DeGroot WTP, where it is treated and used to supply municipal water demands through cities participating in the SCWSP 5. Active participation in local groundwater entities and initiatives, including the SSJGSA, ESJGWA, and the Eastern San Joaquin Subbasin Groundwater Subbasin Sustainability Plan 6. Constructed two groundwater wells to supplement water supply for East Basin.	1. Continue to support GSP implementation activities and annual reporting. 2. Continue to encourage conjunctive use in agriculture by supplying pressurized irrigation service, and by supplying surface water at a lower rate than the cost of pumping groundwater 3. Continue to encourage conjunctive use in urban areas through the SCWSP Phase II Expansion. 4. Support Ripon and Escalon to connect to the WTP.
10608.48.c(9)	Automate canal control structures	Being Implemented	1. Automation of all 24 lateral headings and all control structures on the MSC and MDC to improve customer service while reducing system losses. 2. Automation of the SIDE reservoir to maintain steady water supply to three adjacent laterals. 3. Implementation of an extensive SCADA system to provide communication, monitoring, and control of automated sites, including remote on/off control of 28 groundwater wells. 4. Automation of 19 miles of pipelines and deliveries to a current total of 77 customers (as of 2020) in the Irrigation Enhancement Project. 5. Infrastructure improvements to enhance canal automation: <ul style="list-style-type: none"> a. installation of new automated gates (Rubicon SlipMeters, etc.), including one at Valley Home Drop b. installation of float valves, automated gates, and remote water level sensor for automatic flow regulation and downstream level control 	1. SSJID will continue to evaluate opportunities for additional automation to increase delivery flexibility and steadiness and to reduce operational spillage. 2. Continue infrastructure improvements to enhance canal automation: <ul style="list-style-type: none"> a. install automated gates (Rubicon SlipMeters, BladeMeters, etc.) b. install float valves for automatic flow regulation and support of downstream level control 3. Upgrade and replace aging SCADA and automation infrastructure on the MDC.
10608.48.c(10)	Facilitate or promote customer pump testing and evaluation	Being Implemented	1. SSJID facilitates and promotes customer pump testing and evaluation by providing links on its website to programs that provide these services, such as offered by PG&E (http://www.pumpefficiency.org/).	1. Continue facilitating and promoting customer pump testing programs 2. Consider cost sharing for pump efficiency testing as part of its On-farm Water Conservation Program, if reinstated. 3. Consider Metering District owned wells.
10608.48.c(11)	Designate a water conservation coordinator who will develop and implement the water management plan and prepare progress report.	Being Implemented	1. SSJID added a permanent, full time water conservation coordinator in 2011.	1. Continue to employ a full time water conservation coordinator.

Intentionally Left	EWMP	Position	Implemented Activities	Planned Activities
10608.48.c(12)	Provide for the availability of water management services to water users.	Being Implemented	1. SSJID provides for the availability of water management services through scientific irrigation scheduling and soil moisture monitoring conservation measures, for example, as part of its On-Farm Water Conservation Program. 2. Links to CIMIS and other water management information available on District website 3. Periodic irrigation newsletter produced and distributed to growers, staff, and the public. 4. Educational materials and resources available to farmers, staff, and the public through the District’s website. 5. Educational opportunities and presentations offered to the public by District staff 6. Historical water use data is available to growers in the Irrigation Enhancement Project (also known as the Division 9 project). 7. In 2015, Drought Task Force aided growers in improving on-farm irrigation efficiencies. 8. Made regular water usage information available online to growers (since 2013). 9. Made on-farm meter readings available to growers online through web portal (since 2018). 10. Added SCADA to 160 magnetic flow meters.	1. Continue current activities. 2. Provide regular water usage information as part of implementing volumetric billing. 3. Continue adding SCADA monitoring to magnetic flow meters measuring farm deliveries. 4. Seek grant for Advanced Metering Infrastructure
10608.48.c(13)	Evaluate the policies of agencies that provide the supplier with water to identify the potential for institutional changes to allow more flexible water deliveries and storage.	Being Implemented	1. SSJID actively evaluates the effect of supplier (Reclamation) and Tri-Dam Project policies and operational practices and seeks policy changes to alleviate water supply constraints. 2. SSJID actively participates in SGMA-related entities and efforts (SSJGSA, ESJGWA, implementation of the Eastern San Joaquin Groundwater Subbasin GSP)	1. Continue current activities.
10608.48.c(14)	Evaluate and improve the efficiencies of the supplier’s pumps.	Being Implemented	1. Periodic evaluation and improvements of pumps by performing periodic pump efficiency tests to identify cost effective energy and/or water conservation improvements. 2. Maintain more than 20 GW pumps 3. Maintain 7 pumps at the East Basin Reservoir and 5 at the SIDE Reservoir.	1. Meter District owned wells. 2. Continue testing and periodic refurbishment or replacement of pumps and motors. 3. Add any new pumps to the existing testing program. 4. Rebuild deep well operating at 30 percent efficiency

Intentionally Left Blank

7.6 EVALUATION OF WATER USE EFFICIENCY IMPROVEMENTS

CWC §10608.48(d) requires that AWMPs include:

... a report on which efficient water management practices have been implemented and are planned to be implemented, an estimate of the water use efficiency improvements that have occurred since the last report, and an estimate of the water use efficiency improvements estimated to occur five and 10 years in the future.

A description of which EWMPs have been implemented has been provided previously in Section 7. This section provides an evaluation of EWMP implementation and an estimate of water use efficiency (WUE) improvements that have occurred in the past and are expected to occur in the future.

From SSJID's perspective, the value of evaluating water use efficiency (WUE) improvements (and EWMP implementation in general) is to identify what the benefits of EWMP implementation are, and to identify those additional actions that hold the potential to advance SSJID's water management objectives. The District's primary water management objective is to maintain a reliable, affordable, high quality water supply for agriculture and other uses. To that end, SSJID has taken action to develop and maintain reliable surface water and groundwater supplies, to prevent or reduce losses from the distribution system in order to increase operational efficiency, to promote the efficient use of water at the farm level, and to meet changing environmental and other demands that affect the flexibility with which the District can deliver and store water. Recent examples of these actions include the SIDE project in 2003, the Irrigation Enhancement Project (also known as the Division 9 Project) in 2012, the recent feasibility study on District-wide pressurization, and ongoing Water Master Planning process.

First and foremost among the issues that must be considered in any evaluation of the benefits of EWMP implementation and resulting WUE improvements is how water management actions affect the water balance (Davenport and Hagan, 1982; Keller, et al., 1996; Burt, et al., 2008; Clemmens, et al., 2008; Canessa, et al., 2011). Accordingly, any evaluation of EWMP implementation and WUE improvements for SSJID must consider how water balance changes relate to the District's mission and water management objectives. For example, flows to deep percolation and seepage that could be considered losses in some settings are critical to maintain the long-term sustainability of the underlying groundwater basin. Reductions in these flows resulting from EWMP implementation could be considered WUE improvements at the farm or District scale, but have the consequential effect of diminishing recharge of the underlying groundwater system. Other flows that could be considered losses at the District or farm scale such as spillage and tailwater, respectively, are also recoverable. For example, spillage from the SSJID distribution system is available for beneficial use by downgradient water users. The only distribution system or on-farm losses that are not recoverable within SSJID, the underlying

groundwater basin, or the San Joaquin River Basin as a whole are canal and reservoir water surface evaporation and evaporation from irrigation application. These components represent a small portion of SSJID's water supply. An implication of this is that very little "new" water can be made available through water conservation in SSJID.

An essential first step in evaluating EWMP implementation and water use efficiency improvements is a comprehensive, quantitative, multi-year water balance (see Section 5). The quantitative understanding of the water balance flow paths enables identification of targeted flow paths for WUE improvements, along with improved understanding of the beneficial impacts and consequential effects of EWMP implementation at varying spatial and temporal scales. The water balance enables evaluation of potential changes in flow path quantities and timing for any given change in water management.

Even where comprehensive, multi-year water balances have been developed, evaluating water balance impacts and WUE improvements is not a trivial task. Issues of spatial and temporal scale and relatively small changes in flow paths resulting from many water management improvements (relative to day to day and year to year variation in water diversions and use) coupled with inaccuracies inherent in even the best water measurement greatly complicate the evaluation of water balance impacts. The implications of recoverable and irrecoverable losses at varying scales complicate the evaluation of WUE improvements, and consequential, potentially unintended consequences must be considered (Burns et al. 2000, AWMC 2004).

As part of assembling this AWMP, SSJID has identified the targeted flow paths associated with implementation of each EWMP and the water management benefits of each EWMP, along with the potential consequential effects of implementation. A brief discussion of the benefits associated with implementation of each EWMP is provided, along with a brief discussion of consequential effects that must be considered. A summary of targeted flow paths, beneficial impacts, and consequential effects associated with implementation of each EWMP by SSJID is provided in Table 7-6.

Table 7-6. Summary of WUE Improvements by EWMP

Water Code Reference No.	EWMP	Implementation Status	Targeted Flow Path(s)	Benefits	Consequential Effects	Notes (See End of Table)
10608.48.b (1)	Measure the volume of water delivered to customers with sufficient accuracy	Being Implemented	None	Supports Evaluation of EWMPs	Not Applicable	1
10608.48.b (2)	Adopt a pricing structure based at least in part on quantity delivered	Being Implemented	Farm Deliveries, IL Tailwater, IL Deep Percolation _{aw} , Deliveries from Joint Supply Canal, District Outflows	Volumetric pricing creates a modest incentive to reduce on-farm deliveries, primarily through reduced tailwater and deep percolation. In aggregate, reduced deliveries result in decreased system inflows and corresponding reductions in drainage outflows. Available water not diverted could allow for service area expansion (annexation) or be available for transfer. Additionally, water quality benefits may occur through reduced tailwater and deep percolation.	Reduced deep percolation results in reduced beneficial recharge of the underlying groundwater system. Reduced drainage outflows from tailwater result in reduced water available for beneficial use by downgradient agricultural or environmental water users.	2
10608.48.c (1)	Facilitate alternative land use for lands with exceptionally high water duties or whose irrigation contributes to significant problems, including drainage.	Not Technically Feasible	Not Applicable	Not Applicable	Not Applicable	3
10608.48.c (2)	Facilitate use of available recycled water that otherwise would not be used beneficially, meets all health and safety criteria, and does not harm crops or soils.	Being Implemented	Farm Deliveries, Deliveries from Joint Supply Canal	Use of available recycled water within the District reduces necessary deliveries from the Joint Supply Canal and necessary farm deliveries by a similar volume.	Not Significant	2
10608.48.c (3)	Facilitate financing of capital improvements for on-farm irrigation systems	Being Implemented	Farm Deliveries, IL Tailwater, IL Deep Percolation _{aw} , Deliveries from Joint Supply Canal, District Outflows	SSJID funding of on-farm improvements could result in reductions in on-farm deliveries through reduced tailwater and deep percolation. In aggregate, reduced deliveries result in decreased system inflows and corresponding reductions in drainage outflows. Available water not diverted could allow for service area expansion (annexation) or be available for transfer. Additionally, water quality benefits may occur through reduced tailwater and deep percolation.	Reduced deep percolation results in reduced beneficial recharge of the underlying groundwater system. Reduced drainage outflows from tailwater result in reduced water available for beneficial use by downgradient agricultural or environmental water users.	2
10608.48.c (4)	Implement an incentive pricing structure that promotes one or more of the following goals: (A) More efficient water use at farm level, (B) Conjunctive use of groundwater, (C) Appropriate increase of groundwater recharge, (D) Reduction in problem drainage, (E) Improved management of environmental resources, (F) Effective management of all water sources throughout the year by adjusting seasonal pricing structures based on current conditions.	Being Implemented	Varies	Volumetric pricing incentivizes goals A and D, resulting in on-farm benefits as described for the volumetric pricing EWMP (10608.48.b(2)). Provision of surface water at lower rates than the cost of groundwater pumping incentivizes goals B and C and improves the reliability of regional water supplies.	Consequential effects are the same as described for the volumetric pricing EWMP (10608.48.b(2)).	2
10608.48.c (5)	Expand line or pipe distribution systems, and construct regulatory reservoirs to increase distribution system flexibility and capacity, decrease maintenance and reduce seepage	Being Implemented	Deliveries from Joint Supply Canal, Operational Spillage, Canal Seepage, Farm Deliveries, IL Tailwater, IL Deep Percolation _{aw} , District Outflows	SSJID regulating reservoirs allow for improved on-farm delivery steadiness and flexibility, potentially providing a modest reduction in on-farm deliveries due to reduced deep percolation and tailwater. Reservoirs allow operators to reduce operational spillage. Lining and pipeline conversion provide maintenance and operational benefits while also substantially reducing seepage in some areas. In aggregate, reduced recoverable losses at the farm and district scale result in decreased system inflows. Available water not diverted could allow for service area expansion (annexation) or be available for transfer. Additionally, water quality benefits may occur through reduced tailwater and deep percolation.	Reduced deep percolation and seepage result in reduced beneficial recharge of the underlying groundwater system. Reduced drainage outflows result in reduced water available for beneficial use by downgradient agricultural or environmental water users.	2

Water Code Reference No.	EWMP	Implementation Status	Targeted Flow Path(s)	Benefits	Consequential Effects	Notes (See End of Table)
10608.48.c (6)	Increase flexibility in water ordering by, and delivery to, water customers within operational limits	Being Implemented	Deliveries from Joint Supply Canal, Operational Spillage, Farm Deliveries, IL Tailwater, IL Deep Percolation _{aw} , District Outflows	Changes in ordering and delivery practices, coupled with improvements to the SSJID distribution system and operation result in increased control for DMs and improved farm delivery steadiness and flexibility. Farm deliveries could be reduced due to reduced deep percolation and tailwater. System improvements result in greater operational efficiency and, potentially, reductions in spillage. In aggregate, reduced recoverable losses at the farm and district scale result in decreased system inflows. Available water not diverted could allow for service area expansion (annexation) or be available for transfer. Additionally, water quality benefits may occur through reduced tailwater and deep percolation.	Reduced deep percolation results in reduced beneficial recharge of the underlying groundwater system. Reduced drainage outflows result in reduced water available for beneficial use by downgradient agricultural or environmental water users.	2
10608.48.c (7)	Construct and operate supplier spill and tailwater recovery systems	Being Implemented	Deliveries from Joint Supply Canal, District Outflows	Current levels of tailwater interception and spillage recovery and prevention will continue to reduce drainage outflows from SSJID. As a result, reduced outflows result in decreased system inflows. Available water not diverted could allow for service area expansion (annexation) or be available for transfer.	Reduced drainage outflows result in reduced water available for beneficial use by downgradient agricultural or environmental water users.	
10608.48.c (8)	Increase planned conjunctive use of surface water and groundwater within the supplier service area	Being Implemented	Deliveries from Joint Supply Canal, District Pumping	Increased conjunctive management benefits SSJID by improving long-term water supply reliability through reliance primarily on surface water to minimize withdrawals from the groundwater system and provide beneficial groundwater recharge.	Not Significant	2
10608.48.c (9)	Automate canal control structures	Being Implemented	Deliveries from Joint Supply Canal, Operational Spillage, Farm Deliveries, IL Tailwater, IL Deep Percolation _{aw} , District Outflows	Automation of the SSJID distribution system results in increased control for system operators and improved farm delivery steadiness and flexibility. Farm deliveries could be reduced due to reduced deep percolation and tailwater. System improvements result in greater operational efficiency and, potentially, substantial reductions in spillage. In aggregate, reduced recoverable losses at the farm and district scale result in decreased system inflows. Available water not diverted could allow for service area expansion (annexation) or be available for transfer. Additionally, water quality benefits may occur through reduced tailwater and deep percolation.	Reduced deep percolation results in reduced beneficial recharge of the underlying groundwater system. Reduced drainage outflows result in reduced water available for beneficial use by downgradient agricultural or environmental water users.	2
10608.48.c (10)	Facilitate or promote customer pump testing and evaluation	Being Implemented	None	Improved pumping efficiency by SSJID's customers does not affect the SSJID water balance but results in decreased energy demand and reduced pumping costs for customers. There are no direct benefits to SSJID.	Not Significant	
10608.48.c (11)	Designate a water conservation coordinator who will develop and implement the water management plan and prepare progress report.	Being Implemented	Varies	See Comment	See Comment	4
10608.48.c (12)	Provide for the availability of water management services to water users.	Being Implemented	Deliveries from Joint Supply Canal, Farm Deliveries, IL Tailwater, IL Deep Percolation _{aw} , District Outflows	Farm water management support by SSJID could result in reductions in on-farm deliveries through reduced tailwater and deep percolation. In aggregate, reduced deliveries result in decreased system inflows and corresponding reductions in drainage outflows. Available water not diverted could allow for service area expansion (annexation) or be available for transfer. Additionally, water quality benefits may occur through reduced tailwater and deep percolation.	Reduced deep percolation results in reduced beneficial recharge of the underlying groundwater system. Reduced drainage outflows from tailwater result in reduced water available for beneficial use by downgradient agricultural or environmental water users.	2
10608.48.c (13)	Evaluate the policies of agencies that provide the supplier with water to identify the potential for institutional changes to allow more flexible water deliveries and storage.	Being Implemented	Deliveries from Joint Supply Canal	Changes in the policies of agencies that affect SSJID's flexibility and storage in using its surface water supply could allow for limited improvements in system operation and reductions in system losses. Available water not diverted could allow for service area expansion (annexation) or be available for transfer.	Reduced drainage outflows from operational spillage could result in reduced water available for beneficial use by downgradient agricultural or environmental water users.	
10608.48.c (14)	Evaluate and improve the efficiencies of the supplier's pumps.	Being Implemented	None	Improved pumping efficiency of SSJID's pumps and prioritizing repairs and replacement based on pump evaluations results in decreased energy demand and reduced pumping costs for SSJID and increases pump reliability. There are no direct impacts to water balance flow paths.	Not Significant	

Notes:

1. Although delivery measurement does not directly affect any flow paths, it will provide the basis for improved understanding of the overall water balance in the future.
2. SSJID works to balance tradeoffs between incentivizing on-farm water conservation and maintaining long-term surface water and groundwater reliability for the region.
3. Such conditions do not exist in SSJID. As a result, it is not technically feasible to implement this EWMP.
4. Implementation of the AWMP by SSJID's Water Conservation Coordinator/Water Operations Supervisor, General Manager, District Engineer, and other staff as appropriate is the mechanism by which all EWMPs are implemented and targeted benefits are realized.

WUE definitions vary. For purposes of evaluating WUE improvements associated with EWMP implementation by SSJID, specific WUE improvement categories or objectives, as described by CALFED and DWR (CALFED 2006, DWR 2012b), have been identified that correspond to each EWMP. Potential WUE improvements include reduction of irrecoverable losses, increased local supply, increased local flexibility, increased in-stream flow, improved water quality, and improved energy efficiency. Definitions for each of the WUE improvement categories have been developed and are provided in Table 7-7 along with an evaluation of improvement possible with pressurized irrigation service. Note that the WUE improvement categories are not mutually exclusive in many cases. For example, reductions in irrecoverable losses could be used to increase local supply. The applicability of each EWMP to each WUE improvement category based on SSJID's water management activities has been identified and is presented in Table 7-8.

In order to more explicitly report an estimate of WUE improvements that have occurred since the last AWMP and an estimate of WUE improvements expected to occur five and ten years in the future, SSJID has estimated the qualitative magnitude (expressed as None, Limited, Modest, or Substantial in order of increasing relative magnitude) for the targeted flow paths associated with each EWMP relative to the applicable WUE improvement categories identified in Table 7-7. Past WUE improvements are estimated relative to no historical implementation. WUE improvements relative to the last AWMP are evaluated qualitatively with respect to the 2020 AWMP. Future WUE improvements are estimated for five years in the future (2030) relative to 2025 and for ten years in the future (2035) relative to 2030. The result of this evaluation is provided in Table 7-9.

SSJID will continue to seek out and implement water management actions that meet its overall water management objectives and result in WUE improvements. SSJID staff regularly attend water management conferences and evaluate technological advances in the context of SSJID's water management objectives and regional setting. The continuing review of water management within SSJID, coupled with exploration of innovative opportunities to improve water management will result in future management improvements by SSJID and additional WUE improvements.

Table 7-7. WUE Improvement Categories

Water Use Efficiency Improvement Category	Definition	Potential Improvement with Pressurized Irrigation Service
Reduce Irrecoverable Losses	Reduce losses that cannot be recovered and used by the water supplier or downgradient users (e.g. evaporation and flows to salt sinks).	Limited
Increase Local Supply	Reduce losses and/or increase storage locally to increase supply available to meet demands, including both near-term (within an irrigation season) and long-term (over more than one year).	Substantial
Increase Local Flexibility	Improve the supplier’s ability to divert, pump, convey, control, and deliver available water supplies to meet customer demands.	Substantial
Increase In-Stream Flow	Increase flow in natural waterways to benefit fisheries or meet other environmental objectives.	Substantial/Modest
Improve Water Quality	Increase the quality of targeted water bodies (i.e. streams, lakes, or aquifers).	Modest
Improve Energy Efficiency	Increase the efficiency of water supplier or customer pumps.	Substantial

1. The feasibility study, when complete, will provide quantitative estimates of improvements in WUE. Until it is complete, qualitative estimates are provided as follows, in increasing relative magnitude: None, Limited, Modest, and Substantial

Table 7-8. Applicability of EWMPs to WUE Improvement Categories.

Water Code Reference No.	EWMP	Implementation Status	Water Use Efficiency Improvement Category					
			Reduce Irrecoverable Losses	Increase Local Supply	Increase Local Flexibility	Increase In-Stream Flow ¹	Improve Water Quality ²	Improve Energy Efficiency
10608.48.b (1)	Measure the volume of water delivered to customers with sufficient accuracy	Being Implemented	No Direct WUE Improvements					
10608.48.b (2)	Adopt a pricing structure based at least in part on quantity delivered	Being Implemented		✓				
10608.48.c (1)	Facilitate alternative land use for lands with exceptionally high water duties or whose irrigation contributes to significant problems, including drainage.	Not Technically Feasible	Not Applicable to SSJID					
10608.48.c (2)	Facilitate use of available recycled water that otherwise would not be used beneficially, meets all health and safety criteria, and does not harm crops or soils.	Being Implemented		✓				
10608.48.c (3)	Facilitate financing of capital improvements for on-farm irrigation systems	Being Implemented		✓				
10608.48.c (4)	Implement an incentive pricing structure that promotes one or more of the following goals: (A) More efficient water use at farm level, (B) Conjunctive use of groundwater, (C) Appropriate increase of groundwater recharge, (D) Reduction in problem drainage, (E) Improved management of environmental resources, (F) Effective management of all water sources throughout the year by adjusting seasonal pricing structures based on current conditions.	Being Implemented		✓				
10608.48.c (5)	Expand line or pipe distribution systems, and construct regulatory reservoirs to increase distribution system flexibility and capacity, decrease maintenance and reduce seepage	Being Implemented	✓	✓	✓			
10608.48.c (6)	Increase flexibility in water ordering by, and delivery to, water customers within operational limits	Being Implemented		✓	✓			
10608.48.c (7)	Construct and operate supplier spill and tailwater recovery systems	Being Implemented		✓				
10608.48.c (8)	Increase planned conjunctive use of surface water and groundwater within the supplier service area	Being Implemented		✓				
10608.48.c (9)	Automate canal control structures	Being Implemented		✓	✓			
10608.48.c (10)	Facilitate or promote customer pump testing and evaluation	Being Implemented						✓
10608.48.c (11)	Designate a water conservation coordinator who will develop and implement the water management plan and prepare progress report.	Being Implemented	The activities of the Water Conservation Coordinator and other SSJID staff to achieve WUE improvements through implementation of the EWMPs are described individually by EWMP.					
10608.48.c (12)	Provide for the availability of water management services to water users.	Being Implemented		✓				
10608.48.c (13)	Evaluate the policies of agencies that provide the supplier with water to identify the potential for institutional changes to allow more flexible water deliveries and storage.	Being Implemented		✓	✓			
10608.48.c (14)	Evaluate and improve the efficiencies of the supplier's pumps.	Being Implemented						✓

1. Increased in-stream flow could be a direct or indirect benefit water transfers between willing buyers and SSJID. For example, an objective of the VAMP program was to increase San Joaquin River flows at certain times and by certain amounts to improve fish habitat.
2. While many EWMPs could result in improved water quality through reduced diversions, reduced deep percolation, or reduced tailwater outflow, the potential for improved water quality in stream flows in particular is very uncertain as it depends on coordination with USBR and others.

Table 7-9. Evaluation of Relative Magnitude of Past and Future WUE Improvements by EWMP.

Water Code Reference No.	EWMP	Implementation Status	Marginal WUE Improvements ^{1,2}			
			Past		Future	
			Relative to No Historical Implementation ³	Since Last AWMP ⁴	5 Years in Future ⁵	10 Years in Future ⁵
10608.48.b (1)	Measure the volume of water delivered to customers with sufficient accuracy	Being Implemented	No Direct WUE Improvements			
10608.48.b (2)	Adopt a pricing structure based at least in part on quantity delivered	Being Implemented	Limited	Limited	Limited to Modest, Depending on Changes to Proposition 218 Case Law	
10608.48.c (1)	Facilitate alternative land use for lands with exceptionally high water duties or whose irrigation contributes to significant problems, including drainage.	Not Technically Feasible	Not Applicable to SSJID			
10608.48.c (2)	Facilitate use of available recycled water that otherwise would not be used beneficially, meets all health and safety criteria, and does not harm crops or soils.	Being Implemented	Modest	None	None to Limited, Depending on Future Opportunities (Timing and Availability)	
10608.48.c (3)	Facilitate financing of capital improvements for on-farm irrigation systems	Being Implemented	Modest (Limited Reduction in Irrecoverable Losses)	Modest	Modest (Limited Reduction in Irrecoverable Losses)	
10608.48.c (4)	Implement an incentive pricing structure that promotes one or more of the following goals: (A) More efficient water use at farm level, (B) Conjunctive use of groundwater, (C) Appropriate increase of groundwater recharge, (D) Reduction in problem drainage, (E) Improved management of environmental resources, (F) Effective management of all water sources throughout the year by adjusting seasonal pricing structures based on current conditions.	Being Implemented	Modest (Goals B & C)	Limited	Limited to Modest (Goals A and D), Depending on Changes to Pricing Structure	
10608.48.c (5)	Expand line or pipe distribution systems, and construct regulatory reservoirs to increase distribution system flexibility and capacity, decrease maintenance and reduce seepage	Being Implemented	Substantial (Limited Reduction in Irrecoverable Losses)	Limited	Modest (Spillage Reduction)	
10608.48.c (6)	Increase flexibility in water ordering by, and delivery to, water customers within operational limits	Being Implemented	Modest	Limited	Modest	
10608.48.c (7)	Construct and operate supplier spill and tailwater recovery systems	Being Implemented	Modest	Limited	Limited to Substantial, Depending on Specific Actions	
10608.48.c (8)	Increase planned conjunctive use of surface water and groundwater within the supplier service area	Being Implemented	Modest	Limited	Limited to Modest, Depending on Specific Actions	
10608.48.c (9)	Automate canal control structures	Being Implemented	Modest	Limited	Modest	
10608.48.c (10)	Facilitate or promote customer pump testing and evaluation	Being Implemented	Limited	None	None to Modest, Depending on Customer Interest	
10608.48.c (11)	Designate a water conservation coordinator who will develop and implement the water management plan and prepare progress report.	Being Implemented	The activities of the Water Conservation Coordinator and other SSJID staff to achieve WUE improvements through implementation of the EWMPs are described individually by EWMP.			
10608.48.c (12)	Provide for the availability of water management services to water users.	Being Implemented	Modest (Limited Reduction in Irrecoverable Losses)	Modest	Substantial (Limited Reduction in Irrecoverable Losses)	
10608.48.c (13)	Evaluate the policies of agencies that provide the supplier with water to identify the potential for institutional changes to allow more flexible water deliveries and storage.	Being Implemented	Modest	Limited	None to Modest, Depending on Outcomes	
10608.48.c (14)	Evaluate and improve the efficiencies of the supplier's pumps.	Being Implemented	Modest	Limited	Limited	

1. As noted herein and throughout this analysis, reductions in losses that result in WUE improvements at the farm or district scale do not result in WUE improvements at the basin scale, except in the case of evaporation reduction. All losses to seepage, spillage, tailwater, and deep percolation are recoverable within SSJID or by downgradient water users within the basin.

2. In most cases, quantitative estimates of improvements are not available. Rather, qualitative estimates are provided as follows, in increasing relative magnitude: None, Limited, Modest, and Substantial.

3. WUE Improvements occurring in recent years relative to if they were not being implemented.

4. 2012 AWMP.

5. WUE Improvements expected in 2025 (five years in the future) and 2030 (ten years in the future), relative to level of implementation in recent years.

8 REFERENCES

2014 Eastern San Joaquin Integrated Regional Water Management Plan Update. Eastern San Joaquin County Groundwater Basin Authority. June 2014. Available at <http://www.water.ca.gov>. (ESJ IRWMP 2014)

Allen, R.G., Pereira, L.S., Howell, T.A. and Jensen, M.E. 2011. Evapotranspiration information reporting: I. Factors governing measurement accuracy. *Agricultural Water Management* 98 (2011) 899-920.

Allen, R. G., Tasumi, M., Morse, A., Trezza, R., Wright, J. L., Bastiaanssen, W. G. M., et al. 2007a. Satellite-based energy balance for mapping evapotranspiration with internalized calibration (METRIC) — Applications. *ASCE Journal of Irrigation and Drainage Engineering*, 133, 395–406.

Agricultural Water Management Council (AWMC). 2004. *Monitoring and Verification: Canal Seepage*. Sacramento, CA.

American Society of Agricultural and Biological Engineers (ASABE). 2007. “Design and Operation of Farm Irrigation Systems.” Hoffman, G.J., Evans, R.G Jensen, M.E., Martin, D.L. and Elliott, R.L.(eds), *Am. Soc. Ag and Bio. Engrs.*, 863 pp.

American Society of Civil Engineers (ASCE). 2015, Forthcoming. “Second Edition Manual 70. Evaporation, Evapotranspiration and Irrigation Water Requirements.” Jensen, M.E. and Allen, R.G.(eds). *Am. Soc. Civ. Engrs.*, 624 pp.

Bastiaanssen, W., Noordman, E., Pelgrum, H., Davids, G., Thoreson, B., and Allen, R. 2005. ”SEBAL Model with Remotely Sensed Data to Improve Water-Resources Management under Actual Field Conditions.” *J. Irrig. Drain Eng.*, 131(1), 85–93.

Burns, J.I., G.G. Davids, A.K. Dimmitt and J. Keller. 2000. *Verification-Based Planning for Modernizing Irrigation Systems*. USCID International Conference on Challenges Facing Irrigation and Drainage in the New Millenium. Fort Collins, CO. Vol. 1, pp. 51-63.

Burt, C., Canessa, P., Schwankl, L. and D. Zoldoske. 2008. *Agricultural Water Conservation and Efficiency in California - A Commentary*. October 2008. 13 pp.

CALFED Bay Delta Program (CALFED). 2006. *Water Use Efficiency Comprehensive Evaluation. Final Report*. CALFED Bay-Delta Program Water Use Efficiency Element.

California Natural Resources Agency (CNRA). 2009. *California Climate Change Adaptation Strategy*. Report to the Governor. California Natural Resources Agency.

California Climate Adaption Planning Guide. 2012. California Natural Resources Agency. Available at <http://resources.ca.gov/climate/>.

Camp, Dresser, and McKee (CDM). 2011. Climate Change Handbook for Regional Water Planning. Prepared for U.S. Environmental Protection Agency and California Department of Water Resources by CDM.

Canessa, P., S. Green and D. Zoldoske. 2011. Agricultural Water Use in California: A 2011 Update. Staff Report, Center for Irrigation Technology, California State University, Fresno. November 2011. 80 pp.

Clemmens, A.J. and C.M. Burt. 1997. Accuracy of Irrigation Efficiency Estimates. ASCE Journal of Irrigation and Drainage Engineering. 123(6) 443-453.

Clemmens, A.J., R.G. Allen, and C.M. Burt. 2008. Technical Concepts Related to Conservation of Irrigation and Rainwater in Agricultural Systems. Water Resources Research. Vol. 44. W00E03, doi:10.1029/2007WR006095.

Davenport, D.C. and R.M. Hagan. 1982. Agricultural Water Conservation in California, With Emphasis on the San Joaquin Valley. Department of Land, Air, and Water Resources. University of California at Davis. Davis, CA. October 1982.

Davids Engineering, Inc. (DE). 2009. South San Joaquin Irrigation District Water Balance Description and Results. San Joaquin Irrigation District. Manteca, CA

Department of Water Resources (DWR). 1967. San Joaquin County Groundwater Investigation - Bulletin 146. California Department of Water Resources.

Department of Water Resources (DWR). 2006a. San Joaquin Valley Groundwater Basin Eastern San Joaquin Subbasin– Bulletin 118. California Department of Water Resources.

Department of Water Resources (DWR). 2006b. Progress on Incorporating Climate Change into Planning and Management of California’s Water Resources. Technical Memorandum. California Department of Water Resources.

Department of Water Resources (DWR). 2008. Managing An Uncertain Future: Climate Change Adaptation Strategies for California’s Water. California Department of Water Resources.

Department of Water Resources (DWR). 2010a. Managing an Uncertain Future. California Water Plan Update 2009. Volume 1, Chapter 5. California Department of Water Resources.

Department of Water Resources (DWR). 2010b. Climate Change Characterization and Analysis in California Water Resources Planning Studies. Final Report. California Department of Water Resources.

Department of Water Resources (DWR). 2012a. Climate Action Plan—Phase 1: Greenhouse Gas Emissions Reduction Plan. California Department of Water Resources.

Department of Water Resources (DWR). 2012b. 2012 Agricultural Water Use Efficiency Draft Proposal Solicitation. PowerPoint Presentation. September 20, 2012. California Department of Water Resources.

Department of Water Resources (DWR). 2014. Managing an Uncertain Future 2014 California Water Plan Update 2013. Volume 1, Chapter 5. October 2014. (DWR)

Department of Water Resources (DWR). 2015. A Guidebook to Assist Agricultural Water Suppliers to Prepare a 2015 Agricultural Water Management Plan. California Department of Water Resources.

German, W. 1942. A Brief History of the South San Joaquin Irrigation District. SRWQCB

Green, C.S. 1895. Irrigation in the San Joaquin. The Work of a Modern “Society on the Stanislaus”. Overland Monthly and Out West Magazine. San Francisco, September 1895. Volume 26, Issue: 153. Pg 320-331.

Intergovernmental Panel on Climate Change (IPCC). 2008. Climate Change and Water. Intergovernmental Panel on Climate Change.

Keller, A., J. Keller, and D. Seckler. 1996. Integrated Water Resource Systems: Theory And Policy Implications. IIMI Res. Rep. 3. International Irrigation Management Institute. Colombo, Sri Lanka.

Kreinberg, G. A. 1994. South San Joaquin Irrigation District Groundwater Management Plan. South San Joaquin Irrigation District.

Natural Resources Conservation Service (NRCS). 2007. Soil Survey Geographic (SSURGO) database for San Joaquin County, California. U.S. Department of Agriculture, Natural Resources Conservation Service.

Marvin, J. 2006. Historical Overview of the Lake Tulloch Area.
<http://www.calaverashistory.org/article/historical-overview-lake-tulloch-area>.

Perspectives and Guidance for Climate Change Analysis. August 2015. California Department of Water Resources Climate Change Technical Advisory Group.

Provost and Pritchard Consulting Group (P&P). 2011. South San Joaquin Irrigation District Urban Water Management Plan. South San Joaquin Irrigation District. Manteca, CA.

San Joaquin County. 2004. Eastern San Joaquin Groundwater Basin Groundwater Management Plan. Northeastern San Joaquin County Groundwater Banking Authority. San Joaquin County Department of Public Works, Stockton, CA.

South San Joaquin Irrigation District (SSJID). 1992. South San Joaquin Irrigation District Inland Surface Water Plan. South San Joaquin Irrigation District. Manteca, CA.

South San Joaquin Irrigation District (SSJID). 2011. South San Joaquin Irrigation District Annual Financial Report, 2010. South San Joaquin Irrigation District. Manteca, CA.

Swihart, J., Haynes, J. and Comer, A. 1994. Deschutes--Canal-Lining Demonstration Project, Construction Report. U.S. Dept. of the Interior, Bureau of Reclamation.

Thoreson, B., Clark, B., Soppe, R., Keller, A., Bastiaanssen, W., and Eckhardt, J. 2009. Comparison of Evapotranspiration Estimates from Remote Sensing (SEBAL), Water Balance, and Crop Coefficient Approaches. World Environmental and Water Resources Congress 2009: pp. 1-15.

UMA Engineering, Inc (UMA). 1989. South San Joaquin Irrigation District Water Management/Conservation Information Report.

University of California at Berkeley (UCB). 2012. Climate Change and Integrated Regional Water Management in California: A Preliminary Assessment of Regional Perspectives. Department of Environmental Science, Policy and Management. University of California at Berkeley.

U.S. Bureau of Reclamation (USBR). 2011. West-Wide Climate Risk Assessments: Bias-Corrected and Spatially Downscaled Surface Water Projections. Technical Memorandum No. 86-68210-2011-01. United States Department of the Interior, Bureau of Reclamation.

U.S. Bureau of Reclamation (USBR). 2015. West-Wide Climate Risk Assessments: Irrigation Demand and Reservoir Evaporation Projections. Technical Memorandum No. 86-68210-2014-01. Available at <http://www.usbr.gov/watersmart/wcra/index.html>. (USBR 2015)

U.S. Geological Survey (USGS). 2009. Climate Change and Water Resources Management: A Federal Perspective. U.S. Geological Survey.

APPENDIX A. AGRICULTURAL WATER MEASUREMENT REGULATION DOCUMENTATION – COMPLETED AND REMAINING CORRECTIVE ACTIONS

Intentionally Left Blank

1 INTRODUCTION

1.1 BACKGROUND

The South San Joaquin Irrigation District (SSJID or District) recognizes the need for accurate farm delivery measurements and uniform standards and procedures for measuring and recording farm water deliveries in order to: (1) provide cost-effective service to customers, and (2) generate improved operational records for planning and analysis. This appendix documents both SSJID's implemented and planned corrective actions for compliance with California Code of Regulations Title 23 Division 2 Chapter 5.1 Article 2 Section 597 (23 CCR §597) in July 2012.

2 COMPLIANCE REQUIREMENTS (23 CCR §597.1)

Briefly summarized, 23 CCR §597 requires agricultural water suppliers that provide water to 25,000 irrigated acres or more to measure the volume of water delivered to customers according to specific accuracy standards on or before July 31, 2012 (23 CCR §597.1(a)). The accuracy of existing measurement devices must be certified within ± 12 percent by volume (23 CCR §597.3(a)(1)). The accuracy of new or replacement measurement devices must be certified within ± 5 percent by volume in the laboratory if using a laboratory certification, or ± 10 percent by volume in the field if using a non-laboratory certification (23 CCR §597.3(a)(2)). The regulation further includes specific requirements for certifying and documenting the accuracy of existing and new measurement devices (23 CCR §597.4). Additionally, suppliers subject to the regulation are required to report certain information in their AWMP (23 CCR §597.4(e)).

SSJID serves more than 25,000 irrigated acres and is therefore subject to these regulations. SSJID has elected to use a laboratory certification approach for all new measurement devices district-wide. Siemens magnetic meters were chosen to measure the flow rate at pump turnouts (20% of deliveries). For deliveries with orifice gates (38% of deliveries) or multiple adjacent valves (40%), magnetic meters could not be used. Further, due to the negligible head across the orifice gates, calibration of these gates is not possible. Measurement methods are currently under study.

3 COMPLETED CORRECTIVE ACTIONS (23 CCR §597.4(E)(4))

SSJID is complying with the SBx7-7 delivery measurement requirements by (1) installing magnetic flow meters to accurately measure deliveries to its customers, (2) monitoring and improving the accuracy of deliveries through existing measurement devices, and (3) adoption of the SSJID WMP to identify, prioritize, and implement a District Capital Improvement Program (CIP).

Adopted in 2022, the SSJID WMP is a 30-year plan for the District's agricultural irrigation service and related water distribution facilities. The WMP sets the stage for system

enhancements to ensure irrigation service reliability over the next 30 years by addressing aging infrastructure, implementing key modernization projects, and outlining financial strategies to pay for necessary upgrades. The plan and Capital Infrastructure Program identifies maintenance, rehabilitation and service improvement projects and priorities, including:

- Improved level of service to meet evolving on-farm irrigation needs (flood conversion to sprinkler and drip/micro methods)
- Regulation and recirculation reservoirs to reduce operational spills and equalize service
- Automated flow control devices
- Canyon Tunnel and other upstream water supply improvements
- Variable rates of pipeline and canal replacement and/or rehabilitation
- Trenchless pipeline rehabilitation program

The WMP will be reviewed at regular intervals to evaluate how strategies are being implemented and to update the plan for the next 30 years.

In 2024, the District applied for a Water and Energy Efficient Grant under the Bureau of Reclamation's WaterSmart Program to fund an Advanced Metering Infrastructure (AMI) meter replacement program and interactive platform using telemetry to report water meter data to the District. The District also intends to make the data available to growers in near real time. The costs to purchase and install the new water meters and telemetry are estimated to be more than \$4 million with additional ongoing maintenance and replacement costs.

SSJID has been implementing a volumetric pricing structure since July 31, 2012. In 2023, the District raised its irrigation rates through a successful Proposition 218 effort.

SSJID's current rate structure has two tiers of volumetric pricing for growers that receive non-pressurized water service. For the 2026 irrigation season, a fixed acreage charge of \$60 per acre charge plus an additional volumetric charge. Growers that receive less than 48 inches per year are charged the 'Tier 1' rate, with a volumetric charge of \$10 per af. Growers pay the 'Tier 2' rate of \$17.50 per af for any water diverted over 48 inches per year.

Parcels that receive pressurized water from the District's Division 9 Irrigation Enhancement Project are subject to the fixed acreage charge and volumetric charges plus the Pressurized Irrigation Rate of \$58.12 per acre-foot. The Pressurization rate consists of energy component and provision for capital assets. On January 27, 2026, there was sufficient protests in opposition to the proposed Pressurized Irrigation Rate which is capped at the current rate of \$58.12 per acre-

foot until such time as the District holds an additional Proposition 218 process and lawfully approves a proposed rate increase.

For properties that do not partake in District surface water irrigation service and irrigate with groundwater, landowners may qualify to sign-off from District services through a Services Abandonment Agreement. These parcels also would not be subject to the charges and rates above, and instead would pay a groundwater recharge fee of \$12 per acre.

At that time, SSJID will re-evaluate the corrective action plan, as needed, to (1) integrate the delivery measurement plan with the facility improvements plans, and (2) ensure timely compliance with the accuracy standards of 23 CCR §597.

3.1 SSJID DELIVERY FACILITIES OVERVIEW

3.1.1 Irrigation Deliveries

The SSJID conveyance system consists of an unlined, open main canal serving 350 miles of laterals, of which 38 miles are open lined canals and 312 miles are cast in place concrete pipelines. Water deliveries to parcels typically occur on a rotational schedule with one delivery point taking the full flow of water (or “head”) delivered at a given time. The standard basin-check flood head is 25 cubic feet per second (cfs). SSJID’s laterals are typically sized to convey one, two, or three heads for rotational delivery to growers. DMs manage the rotational delivery of water on each lateral in their division by scheduling deliveries and opening and closing water control gates according to the schedule. Along laterals sized to convey multiple heads, DMs have the ability to deliver to multiple delivery points at the same time and to allow alternative rotation schedules along the length of the lateral and/or its sub-branches. When more than one owner is served by a delivery point, the full “head” is either split between the owners or passed (rotated) directly from one owner to the next without involving the DM. The delivery duration varies according to parcel size and other factors. SSJID laterals are generally sized to convey one head, although laterals serving large areas may be sized to convey two or even three “heads” to avoid excessive rotation intervals. Typically, multi-head laterals are segmented into reaches where one head is rotated among fields, with the upper lateral reaches passing one or two heads to lower reaches while rotating a head among fields within the reach.

District turnouts were grouped into three main types based on unique physical configurations pertaining to delivery volume measurement:

1. Pumps (Figure A-2) account for 282 deliveries
2. Multiple valves (Figure A-3) account for 586 deliveries
3. Orifice gates (Figure A-4) account for 524 deliveries

A typical pipeline lateral includes all three types of turnouts interspersed along the lateral (Figure A-4) while a typical open canal lateral includes only orifice gates and pumps.

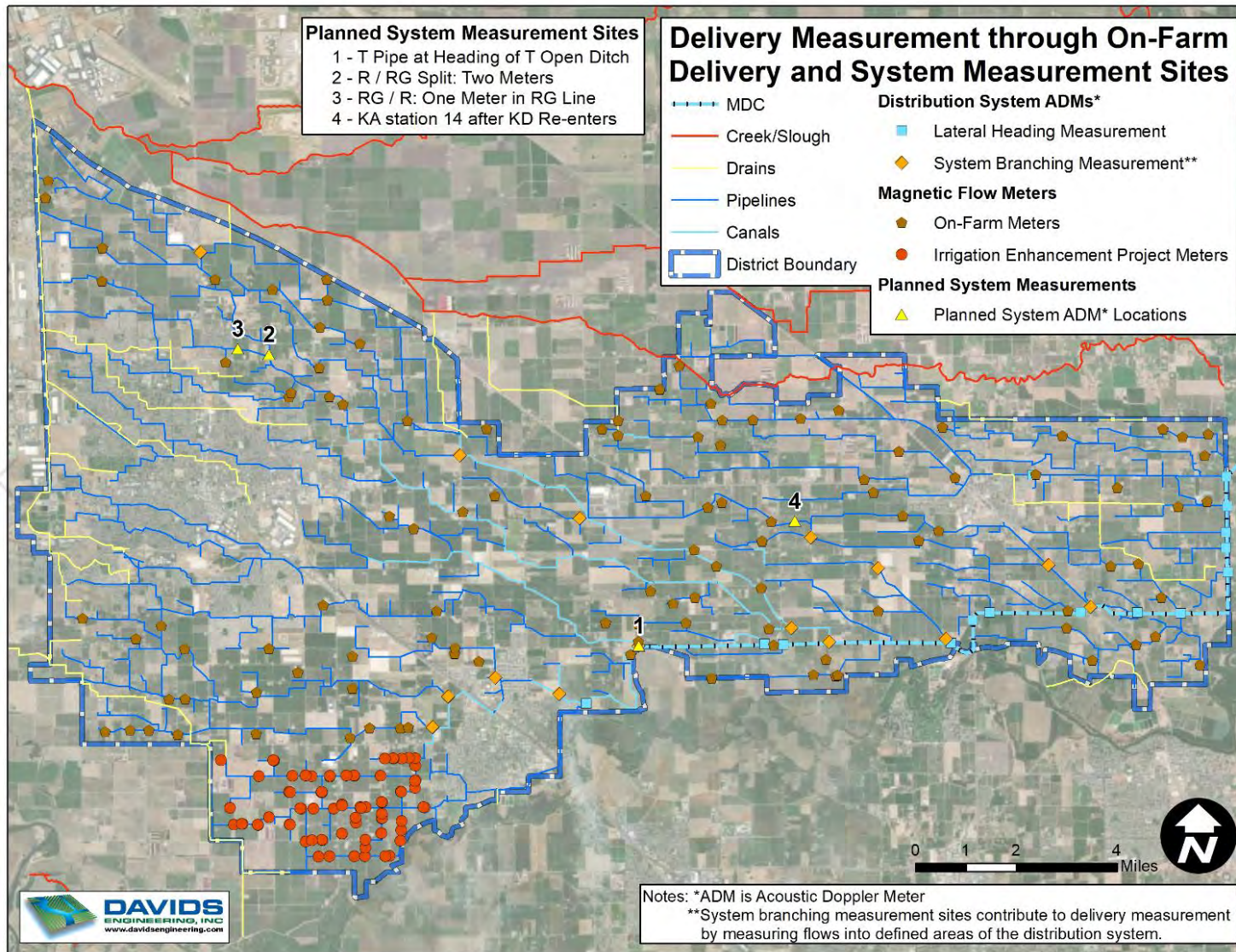

Figure A-1. Map of Delivery Measurement Sites in SSJID.



Figure A-2. Pump turnout on a District pipeline.



Figure A-3. Multiple valve turnout on a District pipeline.



Figure A-4. Orifice gate turnout in a concrete box on a District pipeline.

Flows into the laterals are controlled by maintaining pre-determined levels in the main canal at the location of the lateral head gate and setting the head gate opening to obtain the required flow. On laterals that convey only single heads, SSJID regards the lateral heading as the customer delivery point because the full flow is delivered to just one field at a time (Figure A-5). On laterals that convey multiple heads, the lateral headgates are operated as described above and additional measurement devices are placed between single head lateral reaches so that heads being passed through upper reaches to lower reaches can be measured. On such multiple head laterals, the downstream-most measurement device measures the flow to the lowest single head reach.

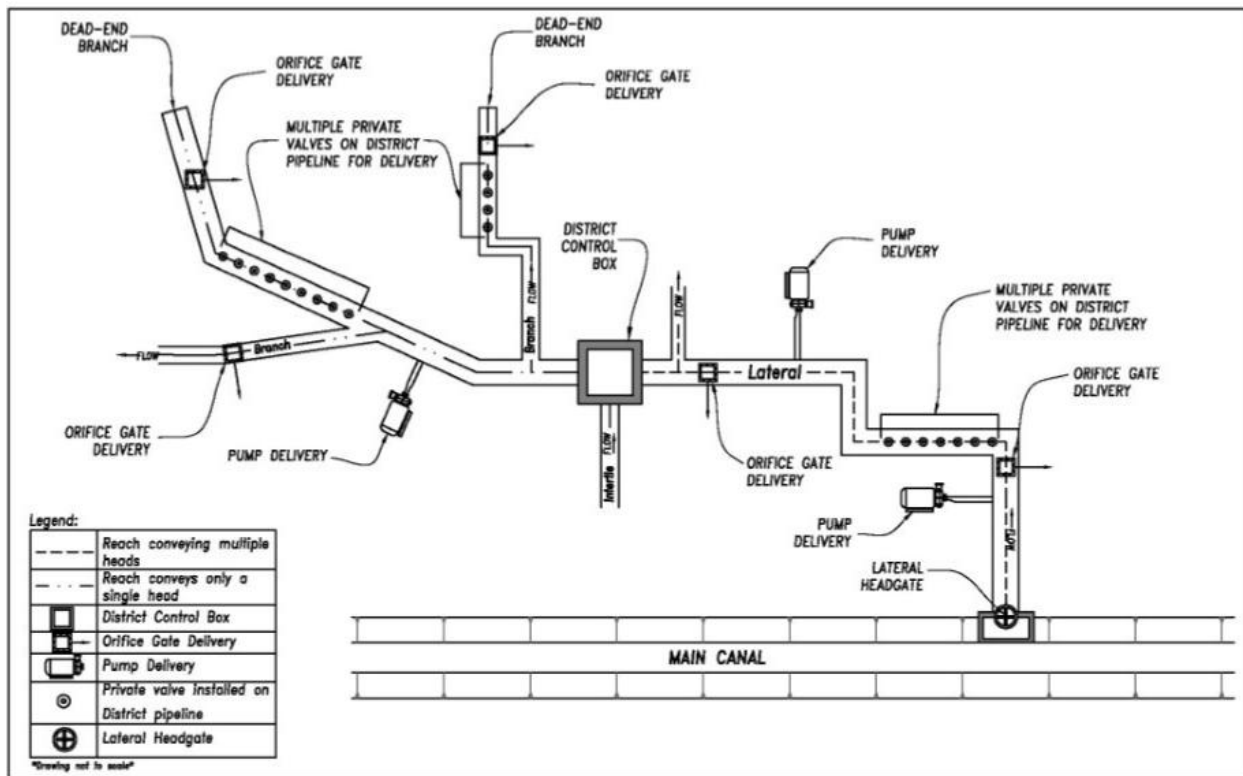

Figure A-5. Typical laterals conveying multiple and single heads with pump, multiple valve, and orifice gate turnouts.

3.1.2 Delivery Measurement Devices for Different Turnout Types

Prior to the initial certification process (CCR 23 §597.4a), the District evaluated the applicability of three measurement devices (orifice gates, ADMs, and magnetic flow meters) at each of the three types of turnouts that exist in the District (pump, multiple valve, and orifice gate turnouts). Table A-1 summarizes the applicability of each measurement device at each turnout. The devices recommended and installed at each turnout type are described below.

Table A-1. Applicability of Selected Measurement Devices at Different Types of Turnouts

Measurement Device	Turnout Type		
	Multiple Valve	Orifice Gate	Pump
Orifice Gate	Use existing orifice gate in center wall of District control box upstream and downstream of multiple valve delivery, or at spill in case of single head lateral that has a spill site.	Use existing farm delivery orifice gate. Requires continuous measurement of gate opening and upstream and downstream water levels. Downstream water level access tubes do not exist on all turnouts.	Not applicable in most situations observed.
Acoustic Doppler Meter	Install new acoustic Doppler meters in District pipelines at control boxes upstream and downstream of pipeline reaches from which just one delivery is made at a time, or at spill in case of single head lateral that has a spill site.	Install new acoustic Doppler meters in District pipelines at control boxes upstream and downstream of pipeline reaches from which just one delivery is made at a time, or at spill in case of single head lateral that has a spill site.	Not applicable in most situations observed.
Magnetic Meter	Not applicable.	Not applicable.	Install new permanent magnetic meter on existing pump discharge piping. May be possible to rate some pump deliveries with portable flow meter.

3.1.2.1 Overview of Delivery Measurement Devices

Three types of measurement devices were evaluated for improving delivery measurement accuracy at the three main turnout types found within SSJID. The recommended measurement devices for each turnout type are described in Table A-2, and in the sections below.

Table A-2. South San Joaquin Irrigation District Farm Delivery Measurement Options by Delivery Type.

Measurement Device	Turnout Type		
	Multiple Valve	Orifice Gate	Pump
Orifice Gate	NOT SELECTED. Multiple valves cannot be measured directly and existing orifice gates (both in center wall of control boxes and to farms) cannot meet CWC § 597 accuracy requirements due to small level differentials. Additionally, numerous challenges involved with installing and maintaining necessary monitoring instruments make this option impractical.		Not applicable in most situations observed.
Acoustic Doppler Meters	SELECTED. Acoustic doppler meters meet CWC § 597 accuracy requirements. Install a network of these meters in District pipelines at strategically selected control boxes that isolate single farm deliveries under most operating conditions. Some deliveries would be measured directly (where only one delivery is made downstream); others indirectly (by differential measurement in cases where additional deliveries are being made downstream). Meter data will be combined with Division Manager records of delivery start and end times to calculate volumetric water deliveries to individual fields.		Not applicable in most situations observed.
Magnetic Meter	Not applicable.	Not applicable.	SELECTED. Only option that meets CWC § 597 accuracy requirements and is adaptable to existing on-farm pumps and piping installations.

3.1.2.2 Pumps

Magnetic flow meters (Figure A-6) have been recommended for installation at delivery points where water is pressurized for irrigation. Pending installation of additional magnetic flow meters, the remaining pump delivery volumes are determined by estimating pump flows based

on the pump size and flow rate required by the irrigation system supplied with water. The District has elected to install magnetic flow meters at pumps where estimated flows do not meet the required 12% accuracy for existing devices, because they provide high measurement accuracy (better than 1% accuracy laboratory certified by the manufacturer) with minimal straight pipe length requirements¹², and have minimal ongoing maintenance requirements.



Figure A-6. Magnetic flow meter on delivery at Ra81.

3.1.2.3 Multiple Valves

No practical measurement device exists that can directly measure flow or volume through the multiple valve turnouts on District pipelines within the accuracy range required by the regulation¹³. However, two alternatives exist to measure the combined flow through all valves. For water delivered through multiple valve turnouts on a single head, “dead-end” pipeline, measurement can be made at a single upstream point using either the orifice gate in the center wall of the District control boxes or an ADM in the pipeline. System losses between the measurement point and delivery point are included in the measurement. Alternatively, for water delivered through multiple valve turnouts on multiple head reaches where one or more head is being passed through to a reach downstream, a volume differential¹⁴ measurement approach is

¹² Irrigation Training and Research Center. 2007. SeaMetrics Ag2000 Irrigation Magmeter Test Results and Summary. Technical Memorandum. Rev. 22 November 2007. California Polytechnic State University, San Luis Obispo, CA.

¹³ Burt, C. and E Greer. 2012. SBx7 Flow Rate Measurement Compliance for Agricultural Irrigation Districts. ITRC Report No. R 12-002. Irrigation Training & Research Center (ITRC). California Polytechnic State University. San Luis Obispo, CA.

¹⁴ “Volume differential” refers to the method of determining the volume delivered as the difference between measured volumes upstream and downstream of the delivery point. The volume differential measurement method is

necessary to account for the water conveyed downstream of the multiple valve turnout. In this case also, any system losses between the measurement points are included in the measurement.

The existing orifice gates in the center wall of the District control boxes are typically operated either fully open (when passing water through) or fully closed (when water is being delivered at or just upstream of the control box) to keep the pressure on the pipelines below the pipeline design pressure. The fully open position often does not allow for measurement due to the absence of, or an extremely small, head drop across the gate. Thus, the ADM in the pipeline is the selected device for measurement at the point of delivery.

ADMs will continue to be installed during the development of the WMP. Following completion of the WMP, SSJID will re-evaluate the corrective action plan to integrate the delivery measurement plan with the facility improvements planned.

3.1.2.4 Orifice Gates

The existing orifice gate turnouts are fully opened so the full head is delivered to minimize pressure on pipelines. This operating practice, common among Districts practicing a rotational delivery system and necessary to prevent damage to conveyance pipelines, results in “small differentials in water levels” (less than 0.1 feet). Data collected for the delivery Q606 (on lateral Q at station 606), illustrates the gate opening (labeled as “goodstem_in”) and water level difference across the gate (labeled as “head_ft”) that occur during normal operation (Figure A-7). This sample data demonstrates the typical operating practice of operating the orifice gate to be either fully open or fully closed, and, when fully open, the extremely small water level difference (0.1 foot) across the gate is evident. These conditions are not conducive to flow measurement because even small inaccuracies in water level measurement can lead to large inaccuracies in calculated head differential and, ultimately, flow rates and volumes. Thus, these orifice gate turnouts cannot be used to measure deliveries “due to small differentials in water levels” (23 CCR §597.3(b)(1)(B)).

These orifice gate turnouts are interspersed among the pump and multiple valve turnouts on the laterals. An alternative is to measure at a single upstream point using an ADM in the pipeline or canal as described previously for a multiple valve turnouts. As for the multiple valve turnouts, there are the two cases one for turnouts on a single head pipeline and a second case for turnouts on a multiple head pipeline, or canal. As with the multiple valve turnouts, the second case requires a volume differential measurement.

a key component of the recommended SSJID delivery measurement plan due to the presence of multiple on-farm irrigation valves being installed on District conveyance pipelines.

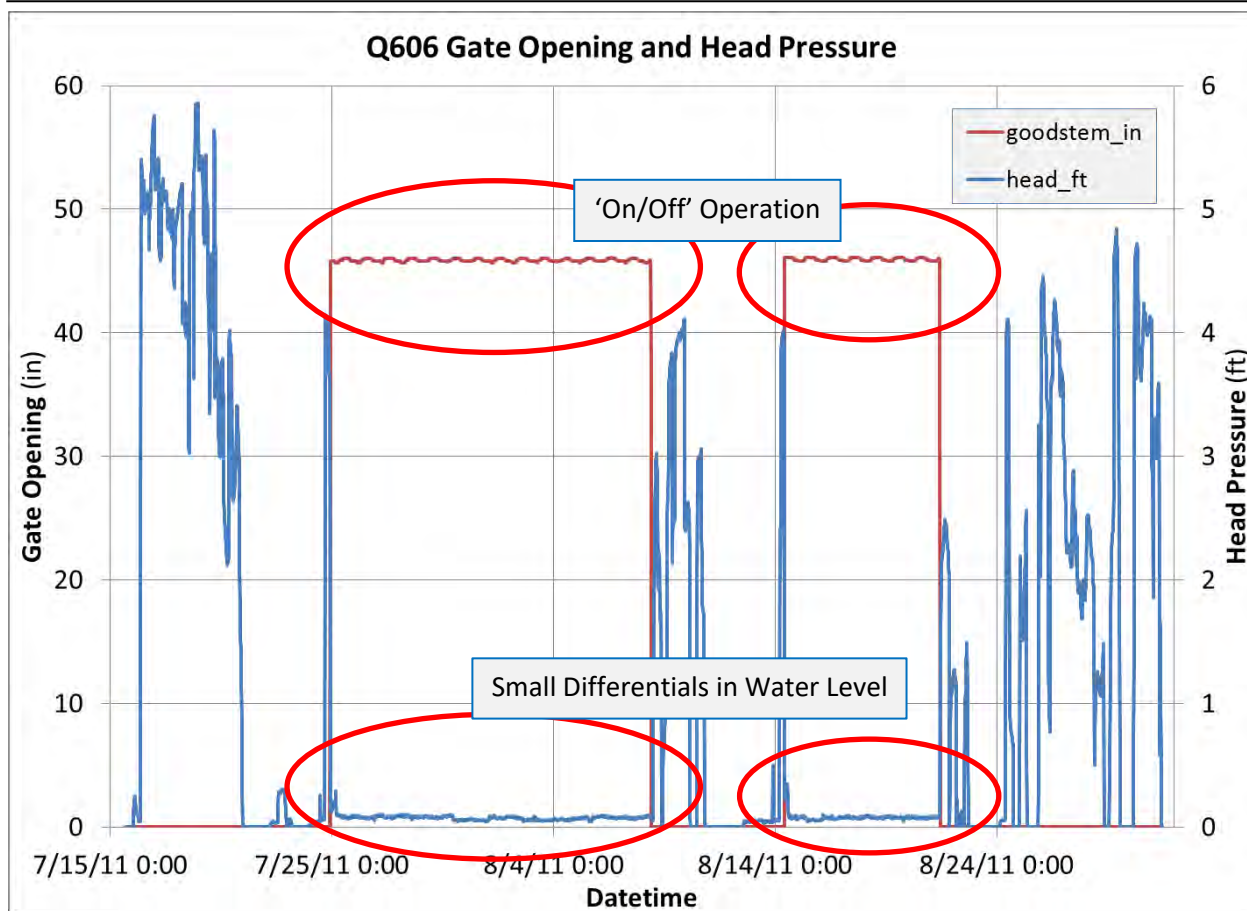

Figure A-7. Orifice gate water level differential measurements.

3.2 SUMMARY OF NEW PERMANENT MEASUREMENT DEVICES

SSJID has continued to install new measurement devices along select laterals and at selected turnouts and pump deliveries throughout the District. New meters have laboratory-certified accuracies that meet the delivery measurement accuracy requirements specified in 23 CCR §597.

SSJID has prioritized installation of meters through the distribution system. Staff has developed an internal prioritization document with specifications for procurement of flow measurement devices and SCADA materials, and identifies the locations most advantageous for delivery measurement. Two types of flow measurement devices are identified in the guide: ADMs, and magnetic flow meters.

ADMs were proposed for installation at specific locations along SSJID’s pipelines and canals to allow tracking of inflows, outflows, bifurcations, and terminal locations. Many deliveries in SSJID are difficult to measure directly as they are either orifice gates (38% of deliveries) or multiple adjacent valves (40%). A pilot project was implemented in 2012 to test the use of SonTek IQ ADMs at selected delivery locations throughout lateral pipelines. The upstream and downstream flow measurements through these devices are used to calculate the deliveries

between. The locations of the SonTek IQs were selected so that each measurement reach could be operated to only deliver to one turnout in the reach at a time. The pilot project measured deliveries to 69 customers and 1,850 acres, concluding that these devices can improve the measurement accuracy for the wide range of delivery flows that SSJID provides.

Based on these findings, the implementation guide recommended ADMs be placed to facilitate operations such that deliveries would be measured by an ADM or the difference between two ADMs. Of the 92 sites where ADMs were proposed in the implementation guide, SSJID has currently installed 42 (46 percent). Table A-3 summarizes the number of ADMs currently installed in SSJID (as of 2024).

Magnetic flow meters were proposed for all delivery points where water is pressurized for irrigation. Of the 689 sites where magnetic flow meters were proposed in the implementation guide, SSJID has currently installed more than 310 (45 percent; see Table A-3). The meters are compatible with pressurized service should the decision be made to implement further pressurized irrigation projects. SSJID has since begun installing SCADA equipment on all magnetic flow meters located at farm turnouts, providing real-time measurement flow data access to DMs and improving record keeping.

Between 2013 and 2019, SSJID and growers combined spent approximately \$2.2 million to install 310 magnetic flow meters on pumped turnouts and an additional estimated \$0.97 million on telemetry for these meters. As previously mentioned, in 2024, the District applied for grant funds of Advanced Metering Infrastructure (AMI) meter replacement program. The District also intends to make the data available to growers in near real time. The costs to purchase and install the new water meters and telemetry are estimated to be more than \$4 million with additional ongoing maintenance and replacement costs.

Additional prioritized measurement devices will be installed during the development of the WMP. Following completion of the WMP, SSJID will re-evaluate the corrective action plan to adapt the delivery measurement plan integrate with the facility improvements planned.

Table A-3. Summary of Delivery Measurement Devices Currently Installed in SSJID (2024).

Site Type	Total Sites Proposed in Implementation Guide	Sites Installed in SSJID ¹	Percent Total Sites Installed
ADMs	92	42	46%
Magnetic Flow Meters	689	310 ²	45%

¹ Sites identified in SSJID GIS data identifying District infrastructure, and mapped to site identifiers in Implementation Guide.

² More than 310 sites installed as of early 2021, excluding sites listed as “under construction.”

SSJID's DMs also work with growers to improve delivery flow measurements where magnetic flow meters are pending, infeasible, or exempt (parcels five acres or less and used only for self-consumption). DMs are able to record and log irrigation durations that are used in the District's volumetric delivery measurements. DMs are also able to improve delivery flow measurements using data available in the field. These actions all support SSJID's efforts for compliance with SBx7-7.

4 BEST PROFESSIONAL PRACTICES (23 CCR §597.4(E)(2 AND 3))

As described previously, turnouts are the delivery points through which water is delivered from the SSJID system to customers. Turnouts are operated for measurement by setting the turnout opening to deliver a standard head (25 cfs) or another specific requested delivery flow rate, based on the turnout type, the necessary head or pressure for delivery, and – since implementing the corrective action plan – conditions specific to each unique turnout type-parcel-lateral type combination.

The method for calculating the delivery flow rate varies depending on the type of turnout. Where magnetic flow meter installation is possible, flow rate and duration are precisely calculated to obtain volume within $\pm 1\%$ accuracy (Attachment A-1). Where magnetic flow meter installation is not possible, SonTek IQ ADMs are used to calculate an upstream-downstream flow rate differential, with an accuracy of $\pm 1\%$ for the measured flow rate (Attachment A-2).

4.1 COLLECTION OF DELIVERY MEASUREMENT DATA

SSJID currently has SCADA collection of delivery measurements from 237 turnouts, as well as monitoring and control at 23 locations in the distribution system and all 27 lateral headings. In 2021, SSJID plans to install 16 new automated gates at various locations throughout the district as well as upgrade and replace aging SCADA infrastructure along the main canal. SCADA data is collected in the District's Wonderware SCADA system.

4.2 FREQUENCY OF MEASUREMENTS

SSJID collects SCADA data at regular 15-minute intervals. Spot flow rate measurements are collected when growers ask for validation measurements of flows and at other times as needed. Start and end dates and times are collected and recorded by DMs for each water delivery event.

4.3 METHOD FOR DETERMINING IRRIGATED ACRES

SSJID maintains a database of irrigated parcels that receive water deliveries. The assessed area of these parcels is included in the TruePoint deliveries database. The assessed area is reduced by 6 percent to estimate irrigated acres, based on past analysis of irrigated lands near SSJID.

4.4 QUALITY CONTROL AND QUALITY ASSURANCE PROCEDURES

SSJID regularly reviews all water measurement data collected through SSJID's SCADA system and internal validation process. Additionally, growers can review the volume delivered through the on-farm meter portal. Growers are billed for the water volume delivered and will likely contact SSJID if there is an error in the reported water volume delivered. If an error is found, SSJID staff promptly correct the error.

Additionally, water data collected by SSJID is used in a District-wide water balance. Prior to using this data in the water balance, the data is reviewed for out-of-range values and other possible errors. When assembled in the water balance, the data is again checked to ensure the highest possible data quality.

SSJID is also embarking on development of a Water Information System (WIS). The District completed conceptual development in 2021 of a WIS and has started integrating certain features with SCADA upgrades. The WIS will provide a centralized, quality-controlled data set to support the District's water budget and SGMA reporting activities including the measurement and tracking of groundwater recharge and pumping estimates.

4.5 CONVERSION OF FLOW RATE TO VOLUME

Magnetic flow meters are used to totalize the volume of deliveries. SonTek ADMs are operated to measure delivery flow rates within 1% accuracy. Delivery volumes are calculated by multiplying these rates by delivery duration. DMs accurately record the delivery duration by identifying the start and stop times from SCADA records. The accuracy of these recorded delivery durations will be assessed, and corrective actions taken if necessary.

5 CORRECTIVE ACTIONS (23 CCR §597.4(D)(2))

The District is actively pursuing grant funds to install and replace Magnetic flow meters under a unified District program for water delivery measurement at the farm-gate. AMI with telemetry accessible data made available to growers in near real time is the goal. The District would be responsible for the installation, function, and replacement of meters and all components necessary to record and transmit data. The improved accuracy of recorded data will be evaluated and corrective actions taken if necessary.

5.1 SCHEDULE AND BUDGET

The District intends to implement the AMI Project by the adoption of the 2030 AWMP.

5.2 FINANCE PLAN

The District annually adopts both an expense and a capital budget including a 5-year capital improvement plan. Currently, the District is financing the capital budget using a pay-go financing model relying on irrigation rate revenues, non-irrigation rate revenues (i.e. Tri-Dam Project and property taxes), and reserves. The District is evaluating the need for additional financing including low interest loans and/or borrowing for additional capital. Grants would also be a major part of the ability for the District to accelerate construction of projects identified in the Water Master Plan.

6 REFERENCES

Burt, C. and E. Geer. 2012. SBx7 Flow Rate Measurement Compliance for Agricultural Irrigation Districts. ITRC. California Polytechnic State University, San Luis Obispo, California.

ATTACHMENT A-1

© Siemens AG 2010

Flow Measurement
 SITRANS F M

MAG 8000 for abstraction and distribution network applications (7ME6810)

Overview



4

Benefits

- Bury meters, IP 68
- Low cost of ownership
- Long-term stability
- Leak detection
- Low flow measurement

Technical specifications

Meter	
Accuracy	Standard calibration: ± 0.4% of rate ± 2 mm/s Extended calibration DN 50 ... DN 300 (2" ... 12"): ± 0.2 % of rate ± 2 mm/s
Media conductivity	Clean water > 20 µs/cm
Temperature	
Ambient	-20 ... +60 °C (-4 ... +140 °F)
Media	0 ... +70 °C (32 ... +158 °F)
Storage	-40 ... +70 °C (-22 ... +158 °F)
Enclosure rating	IP68/NEMA 6P; Cable glands mounted requires Sylgard potting kit to remain IP68/NEMA 6P, otherwise IP67/NEMA 4 is obtained; Factory-mounted cable provides IP68/NEMA 6P
Drinking water approvals	<ul style="list-style-type: none"> • NSF/ANSI Standard 61 (cold water) USA • WRAS (BS 6920 cold water) UK • ACS Listed France • DVGW W270 Germany • Belgaqua (B) • MCERTS (GB)
Custody transfer approval	• OIML R 49 approval
Conformity	<ul style="list-style-type: none"> • PED: 97/23EC • EMC: IEC/EN 61000-6-3, IEC/EN 61000-6-2
Sensor version	DN 25 ... 1200 (1" ... 48")

Measuring principle	Electromagnetic induction
Excitation frequency	
Basic version	
• Battery-powered	DN 25 ... 150 (1" ... 6"): 1/15 Hz DN 200 ... 600 (8" ... 24"): 1/30 Hz DN 700 ... 1200 (28" ... 48"): 1/60 Hz
• Mains-powered	DN 25 ... 150 (1" ... 6"): 6.25 Hz DN 200 ... 600 (8" ... 24"): 3.125 Hz DN 700 ... 1200 (28" ... 48"): 1.5625 Hz
Advanced version	
• Battery-powered	DN 25 ... 150 (1" ... 6"): 1/15 Hz (adjustable up to 6.25 Hz; reduced battery lifetime) DN 200 ... 600 (8" ... 24"): 1/30 Hz (adjustable up to 3.125 Hz; reduced battery lifetime) DN 700 ... 1200 (28" ... 48"): 1/60 Hz (adjustable up to 1.5625 Hz; reduced battery lifetime)
• Mains-powered	DN 25 ... 150 (1" ... 6"): 6.25 Hz DN 200 ... 600 (8" ... 24"): 3.125 Hz DN 700 ... 1200 (28" ... 48"): 1.5625 Hz
Flanges	
EN 1092-1 (DIN 2501)	DN 25 and DN 40 (1" and 1½"); PN 40 (580 psi) DN 50 ... 150 (2" ... 6"): PN 16 (232 psi) DN 200 ... 1200 (8" ... 48"): PN 10 or PN 16 (145 psi or 232 psi)
ANSI 16.5 Class 150 lb	1" ... 24"; 20 bar (290 psi)
AWWA C-207	28" ... 48"; PN 10 (145 psi)
AS 4087	DN 50 ... 1200 (2" ... 48"); PN 16 (232 psi)
Liner	EPDM
Electrode and grounding electrodes	Hastelloy C276
Grounding straps	Grounding straps are premounted from the factory on each side of the sensor.

4/116

Siemens FI 01 - 2011

6.1 ATTACHMENT A-2

SonTek-IQ ACCESSORIES AND SPECIFICATIONS



Custom-fit for the IQ Pipe, this easy to use mounting ring will make system installation a breeze. Fits pipe diameters from 16 in (41 cm) to 72 in (183 cm).



With the press of a single button, data is yours with the SonTek-IQ Flow Display. No PC required!

Product Dimensions

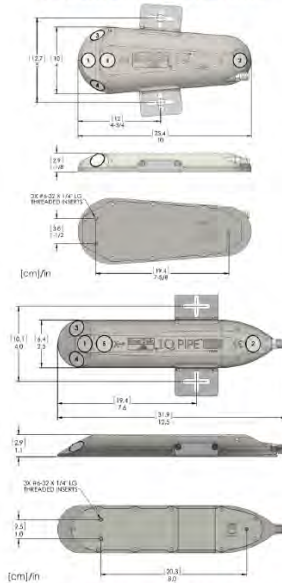

Specifications	SonTek-IQ Standard	SonTek-IQ Plus	SonTek-IQ Pipe
Application	Regular Canals	All Open Channels	Pipes & Culverts
Velocity Measurement			
-Sampling Range	0.05 - 1.5 m (0.16 - 5 ft)	0.05- 5.0 m (0.16 - 16 ft)	0.05 - 5.0 m (0.16 - 16 ft)
-Number of Cells	1	Up to 100	Up to 100
-Cell Size	Dynamically integrated	2 cm - 10 cm (0.8 - 4 in)	2 cm - 10 cm (0.8 - 4 in)
Advanced Data Reprocessing	N/A	✓	✓
Increased Number of Data Fields	N/A	✓	✓
Velocity Measurement			
-Velocity Range	±5 m/s (16 ft/s)		
-Resolution	0.0001 m/s (0.0003 ft/s)		
-Accuracy	±1% of measured velocity, ±0.5 cm/s (0.2 in/s)		
Water Level			
-Vertical Beam Range	0.05 - 1.5 m (0.2 - 5 ft) (Standard); 0.05 - 5.0 m (0.2 - 16 ft) (Plus/Pipe)		
-Water Level Accuracy	0.1% of measured depth or ±0.003 m (0.01 ft) whichever is greater		
-Pressure Sensor Range ¹	30 m (98 ft; 42 psi)		
-Pressure Sensor Accuracy	0.1% of full scale		
Acoustics			
-Acoustic Frequency	3.0 MHz		
-(2) Along Axis Beams	25° off vertical axis, along axis of channel		
-(2) Skew Beams	60° off vertical and 60° off center axis of channel (Standard/Plus); 37° off vertical and 45° off center axis of channel (Pipe)		
Communications	RS232, SDI-12, Modbus, Analog (via optional Flow Display)		
Data Storage	4 GB (approximately 1 year)		
Operating/Storage Temperature	-5 to 60° C (23 - 140° F)		
Temperature Sensor	Accuracy ± 0.2° C; Resolution ± 0.01° C		
Tilt Sensor	Accuracy ± 1.0°		
SmartPulse^{HD}	Yes		
Power			
-Input	9-15 VDC		
-Consumption	0.5 - 1.0 W (0.02 when idle)		

¹For use in pressurized pipes. Housing rated to 42 psi.



Founded in 1992 and advancing environmental science globally, SonTek manufactures acoustic Doppler instrumentation for water velocity measurement in oceans, rivers, lakes, harbors, canals, estuaries, industrial pipes and laboratories. SonTek's sophisticated and proprietary technology serves as the foundation for some of the industry's most trusted flow data collection systems. SonTek is headquartered in San Diego, California, and is a brand of Xylem Inc.

SonTek 9940 Summers Ridge Road San Diego CA 92121 Tel +1.858.546.8327 Fax +1.858.546.8150 www.sontek.com	YSI, Inc. 1700/1725 Brannum Lane Yellow Springs, Ohio 45387 Tel +1.937.767.7241 Fax +1.937.767.9353 www.ysi.com	Xylem, Inc. 1133 Westchester Avenue White Plains, NY 10604 Tel +1.914.323.5700 Fax +1.914.323.5800 www.xyleminc.com
---	--	--

www.sontek.com

516-01

© 2015 Xylem, Inc. All rights reserved. SonTek, SonTek-IQ and SmartPulseHD are trademarks of Xylem Inc. or one of its subsidiaries. The SonTek-IQ is made in the USA. Specifications are subject to change without notice. This material is based upon work supported by the Cooperative State Research, Education, and Extension Service, U.S. Department of Agriculture, under Agreement No. 2008-33610-19458. Any opinions, findings, conclusions, or recommendations expressed in this publication are those of the authors and do not necessarily reflect the view of the U.S. Department of Agriculture.

Intentionally Left Blank

APPENDIX B. RULES AND REGULATIONS GOVERNING THE DISTRIBUTION OF WATER IN SSJID

Intentionally Left Blank

TO THE TAXPAYERS AND WATER USERS OF THE
SOUTH SAN JOAQUIN IRRIGATION DISTRICT

These Rules and Regulations have been adopted under the authority of the Irrigation Act (Section 15) and have been passed by three successive readings and by being published and have now become a part of the law governing this District, with all the force of county or municipal ordinances.

It is the desire and intention to carry on the business of the District in a businesslike and economical manner and to distribute the water equitably, and, as near as may be, satisfactory to all water users. No two individuals have exactly the same requirements and while these individual requirements will be met as far as possible, yet there must be general rules and general practices to secure the greatest good to the greatest number.

It is expected that it will be found necessary to modify these rules from time to time to meet the changing conditions in the District, and the Board of Directors will always have an open mind for suggestions for modifications from water users. It is also understood that employees of the District may use a certain amount of judgment and discretion in enforcing the rules when an avoidable injury to any water user may thereby be prevented without doing an injustice to other water users.

Employees must be courteous and considerate in their dealings with the public and must understand that it is their duty to serve as effectively as possible the interests of water users and taxpayers, who in turn, are requested to extend the same courteous consideration to employees that employees will be required to show to them.

Every person in the District should feel a personal responsibility in helping to keep down expenses. This can be done by avoiding doing any damage to canals and structures, by stopping small leaks, reporting weak places and breaks and by NOT taking out or putting in flash boards or raising or lowering gates except under direct supervision of a ditch-tender and by following his directions carefully when so doing, and also by not turning the water loose at night or at other times after promising the ditch tender to keep it.

RULES AND REGULATIONS

*Governing the Distribution
of Water in the South San
Joaquin Irrigation District*



*Adopted April 13, 1915
Amended May 20, 1919*

RULES AND REGULATIONS

Governing the Distribution of Water in the South San Joaquin
Irrigation District.

No. 1 - Control of System:

The canals and works of the District and all takeouts, checks, pipelines, pumps and other structures and devices placed in District canals, laterals, and ditches are under the exclusive control and management of the Superintendent, appointed by the Board of Directors, and no other person, except his employees and assistants, shall have any right to interfere with said canals and works in any manner.

No. 2 - Employees:

The Superintendent shall employ, under authority and subject to confirmation by the Board of Directors, such ditchtenders and other assistants as may be necessary for the proper operation of the system and distribution of the water. Each ditchtender shall have charge of his respective section and shall be responsible to the Superintendent. From the ditchtender's decision an appeal may be made to the Superintendent. From the action of the Superintendent, appeal may be made to the Board of Directors.

No. 3 - Apportionment of Water:

The water will be apportioned to each distributing section by the Superintendent, and in cases of controversy or shortage in water the apportionment shall be made upon the basis of the acreage irrigated from each section.

No. 4 - Rotation of Water:

The water will be furnished in rotation to each irrigator except by agreement between adjoining owners satisfactory to the Superintendent. The method of distributing water in any section shall be under the discretion of the Superintendent, except that if the Superintendent begin at either upper or lower end he must continue the routine as started.

The office of the District and its records are public. All records are open to the inspection and examination of any taxpayer upon request and without assigning a reason for the request. All officials and employees will cheerfully furnish any information or answer any questions asked concerning the affairs of the District. Taxpayers are requested to avail themselves of this source of information.

This booklet is available for free distribution.

BOARD OF DIRECTORS

Reprint including amendments by order of the Board of Directors.
Dated May 20, 1919

Reprinted by order of the Board of Directors.
Dated October 28, 1986

No. 5 - Time Limit:

Each irrigator, with a head of 15 second feet of water will be allowed not to exceed thirty minutes to irrigate an acre of land requiring flooding; and with a larger or smaller head of water, will be required to irrigate more or less land in proportion to the amount of water furnished. But for gardens, trees and vines water will be furnished on request whenever available and will be kept available continuously as far as possible. The time will start when the diverting gate in the District canal is opened, and water must be used night and day continuously until the time limit expires. The head of water or time limit for gardens, trees and vines will not be fixed unless required in time of shortage.

No. 6 - Continuous Use of Water:

Before water is turned into a private individual or party ditch the same shall be in condition satisfactory to the Superintendent, and the water shall be used continuously day and night, and all land upon which water is not used loses its right to water until the next regular irrigation for that ditch.

Properly checked land to be flooded on regular time limit. On unimproved land water may be used up to July 1st for furrow irrigation, providing flooding is not attempted to such an extent as to become a waste of water; waste of water in this instance shall immediately accrue when water commences to collect in low swales, runs upon roads or adjacent lands. A time limit of thirty minutes per acre shall be placed on each acre with a fifteen second foot head of water or a limit of one and one-half hours per acre for five second feet, and if applicant is not in position to handle five second feet of water a time of one and one-half hours to the acre shall be charged against stream of water that applicant is able to handle in the same manner as though he was in a position to receive and handle five second feet.

No. 7 - Notice of Delivery:

Each irrigator will be notified at least 12 hours before water will be delivered to him and further notified of any change in time of delivery, and the irrigator who fails to use his allotment of water during an irrigation will not be entitled to any more water at any future irrigation than if he had used his full share at the time of allotment.

No. 8 - Control of Diverting Gates:

The District's employees alone will be allowed to open the diverting gates or pipelines, and they have full authority to close same as soon as the requisite amount of water for each irrigator has been discharged. When water user requests, or it is evident to District's employee that an extension of time is necessary to adequately irrigate a piece of land that is in all respects properly prepared, same shall be granted; provided, said extension does not materially interfere with schedule of other irrigators on same ditch or lateral, in which case said employee shall forthwith report to the Superintendent, and in case of his absence then to one of his assistants, who shall give final instructions for that particular irrigation.

No. 9 - Using Water Out of Turn:

Any person who uses the water out of his turn and without the permission of his ditchtender forfeits his right to water at the next regular irrigation and is also subject to criminal prosecution.

No. 10 - Waste of Water:

Persons wasting water on roads or vacant land, or land previously irrigated, either willfully, carelessly, or on account of defective ditches or inadequately prepared land, or who shall flood certain portions of the land to an unreasonable depth or amount in order to properly irrigate other portions, will be refused the use of water until such conditions are remedied.

No. 11 - Access to Land:

The authorized agents of the District shall have free access at all times to lands irrigated from the canal system for the purpose of examining the canals and ditches and the flow of water therein.

No. 12 - In Case of Breaks:

When a break or succession of breaks occur under any distributing section, the person to whom the water is last given while the break is being repaired, will be allowed to finish before the water is taken from him, and shall not claim another irrigation for that run. When the breaks are repaired the water will be returned to its original rotation as nearly as possible.

No. 13 - Diverting Gates and Checks:

All diverting gates, pipe lines, and checks are under the control of the District. All pipe takeouts from District canals are subject to exclusive control by the District employees and District padlocks to lock such takeout gates must be installed at the expense of the irrigator.

No. 14 - Acreage of Crops:

Between January 1st and June 1st of each year the Superintendent will obtain from each user of water a signed statement of the kinds of crops and numbers of acres of each which he intends to irrigate. Such other information as may be desirable may be obtained on the same forms.

No. 15 - Use of Right of Way:

Trees, vines and alfalfa must not be planted on the banks of the District canals. Trees and vines interfere with repairs and cleaning, and alfalfa brings gophers into the banks. Permission will be granted to raise cultivated crops on the banks whenever it can be done without injuring the canals or interfering with the distribution of water.

No. 16 - Paralleling of District Ditches:

Where private service ditches are constructed closely paralleling District ditches, a full and complete bank must be constructed adjacent to and in addition to the bank of the District ditch so paralleled.

No. 17 - Liability of Irrigators:

Every consumer of water shall be responsible to the District for all damages caused by his willful neglect or careless acts, and upon his failure to repair such damage after notification by the ditchtender, such repairs shall be made at his expense by the District.

No. 18 - UnLawful Acts:

Attention is called to the fact that any person draining water upon or permitting water to drain upon a public highway is liable to fine and damages. Any interference with the canals or structures under the control of the District is a penal offense.

No. 19 - Building Diverting Gates and Structures:

No openings shall be made or structures placed in any District canal until an application in writing has been made to the Board and permission granted therefore, and without the special permission of the Superintendent. All structures in District canals must be constructed according to requirements of the District and must be maintained in a condition satisfactory to the Superintendent, and must not be changed without the permission of the Superintendent.

No. 20 - Obstructions in Right of Way:

No fences or other obstructions shall be placed across or upon or along any canal bank or right of way of any canal or ditch belonging to the District without the special permission of the Board of Directors. Whenever such special permission shall be granted it shall always be with the distinct understanding that proper openings or passage ways for teams shall be provided, and that such fence or obstruction must be removed whenever requested by the Superintendent.

No. 21 - Preparation of Land for Irrigation:

All parties wishing to prepare land for irrigation may obtain data covering elevations of available water service, proper point on lateral from which to obtain service, and elevation of land which may be watered without endangering the canals, from the engineering department of the District. Before new land may receive water service, same must be inspected by the engineering department, which shall judge as to the feasibility of serving such land. - Amended January 10, 1922.

No. 22 - Enforcement of Rules:

Refusal to comply with the requirements hereof, or transgression of any of the foregoing rules and regulations, or any interference with the discharge of the duties of any official, shall be sufficient cause for shutting off the water, and water will not again be furnished until full compliance has been made with all requirements herein set forth.

No. 23 - Abatement of Nuisance:

No rubbish, soil, garbage, manure or refuse, or dead animal, or animal matter from any barnyard, stable, dairy or hog pen shall be placed in or allowed to be emptied into any ditch or canal of The South San Joaquin Irrigation District, and the Superintendent and ditchtenders of said District are hereby instructed to see that this rule is strictly enforced. All persons found guilty of violating the above rule will be prosecuted for maintaining a nuisance.

No. 24 - Modification of Rules:

These rules may be modified temporarily to meet special conditions.

Section 592, Penal Code of the State of California: Water Ditches, etc., Penalty for Trespass or Interference With.

Every person who shall, without authority of the owner or managing agent, and with intent to defraud, take water from any canal, ditch, flume or reservoir used for the purpose of holding or conveying water for manufacturing, agricultural, mining, irrigating, or generation of power, or domestic use, or who shall without like authority, raise, lower or otherwise disturb any gate or other apparatus thereof, used for the control or measurement of water, or who shall empty or place, or cause to be emptied or placed, into any such canal, ditch, flume or reservoir any rubbish, filth or obstruction to the free flow of the water, is guilty of a misdemeanor.

Section 607, Penal Code of the State of California: Destroying or Injuring Bridges, Dams, Levees, Etc.

Every person who willfully and maliciously cuts, breaks, injures, or destroys any bridge, canal, flume, aqueduct, levee, embankment, reservoir, or other structure erected to create hydraulic power, or to drain or reclaim any overflowed tide or swamp land, or to store or conduct water for mining, manufacturing, reclamation, or agricultural purposes, or for the supply of the inhabitants of any city or town, or any embankment necessary to the same, or either of them, or willfully or maliciously makes, or causes to be made, any aperture in such dam, canal, flume, aqueduct, reservoir, embankment, levee or structure, with intent to injure or destroy the same; or draws up, cuts, or injures any piles fixed in the ground for the purpose of securing any sea bank or sea walls, or any dock, quay, jetty, lock or sea wall; or who, between the first day of October and the fifteenth day of April of each year, plows up or loosens the soil in the bed or on the sides of such natural watercourse or channel, without removing such soil within twenty four hours from such watercourse or channel; or who, between the fifteenth day of April and the first day of October of each year, shall plow up or loosen the soil in the bed or on the sides of such natural watercourse or channel, and shall not remove therefrom the soil so plowed up or loosened before the first day of October next thereafter, is guilty of a misdemeanor, and upon conviction, punishable by a fine not less than one hundred dollars and not exceeding one thousand dollars, or by imprisonment in the county jail not exceeding two years, or by both; provided, that nothing in this section shall be construed so as to in any manner prohibit any person from digging or removing soil from any such watercourse or channel for the purpose of mining.

APPENDIX C. PROGRAM DESCRIPTION FOR 2014 ON-FARM WATER CONSERVATION PROGRAM

Intentionally Left Blank



ON-FARM WATER CONSERVATION PROGRAM

2014 PROGRAM DESCRIPTION

SOUTH SAN JOAQUIN IRRIGATION DISTRICT



TABLE OF CONTENTS

SOUTH SAN JOAQUIN IRRIGATION DISTRICT.....	C-220
Table of Contents.....	C-221
Background and Objectives.....	C-222
Enrollment Process.....	C-223
Solicitation and Application Process.....	C-223
Eligibility Requirements.....	C-223
Selection Process.....	C-224
Conservation Measures.....	C-225
Physical Improvements.....	C-225
Delivery Measurement for Pumped Deliveries.....	C-225
Conversion from Flood to Sprinkler or Drip/Micro Irrigation.....	C-227
Drainage Relief Option.....	C-228
Management Practices.....	C-229
Scientific Irrigation Scheduling & Soil Moisture Monitoring.....	C-229
District Services.....	C-230
Valve Packing.....	C-230
Maximum Cost Share Payment per Grower.....	C-230
Interaction with Other, Non-District Programs.....	C-230
Payment Approval and Processing.....	C-231
Monitoring and Verification.....	C-231
APPENDIX A: Application for Program Participation.....	C-232
APPENDIX B: Applicable NRCS Conservation Practice Standards.....	C-236
APPENDIX C: Consent to South San Joaquin Irrigation District’s Entry of Property to Read and Owner’s Agreement to Maintain Flow Meter.....	C-238

BACKGROUND AND OBJECTIVES

In the early 1900s, the South San Joaquin Irrigation District's system was built for flood irrigation. Over the years, the practices of growers have changed as they work to conserve water and to improve crop yields with the installation of more efficient irrigation systems and implementation of advanced farming practices. In recognition of the farmers' efforts, and to comply with State law regarding agricultural water use, SSJID provides financial incentives to accelerate improvements to the existing distribution system, enhance farm irrigation practices and provide for measurement of water usage. The intent of this Program is to engage as many growers as possible.

SSJID has developed an on-farm water conservation program (Program) to promote and incentivize on-farm physical improvements, irrigation management practices and water measurement (together referred to as Conservation Measures) that promote water conservation. From a Program perspective, water conservation is defined as use of less water to accomplish the same purpose by encouraging the efficient use of District surface water to meet crop water requirements.

SSJID's goal is to ensure that water is being used efficiently and that it is being put to beneficial use. The District has implemented the on-farm water conservation program in order to work together to achieve the shared water management goals of the growers and the District. The Program also supports ongoing efforts to preserve existing water rights and to comply with current and emerging regulations.

This Program helps the District satisfy the new regulatory requirements of California Senate Bill SBx 7-7, which took effect January 1, 2010 and mandates measurement of individual farm deliveries and implementation of Efficient Water Management Practices (EWMPs) including both District and on-farm improvements. Additionally, it is anticipated that this Program will enhance the control of available surface water and groundwater supplies while promoting improved crop production within SSJID. This program, along with other initiatives the District is evaluating, will provide improved farm delivery measurement and support compliance with SBx 7-7.

A focused set of conservation measures have been included in the Program. In future years, additional conservation measures may be added based on experience with the Program.

Cost shares made available by the Program have been approved for the 2014 growing season. This document provides a detailed description of the 2014 Program to be implemented in November 2013. Cost share offerings for implementation of conservation measures for 2015 will be the subject of future Board decision. For the 2014 Program, participants will be eligible for cost share payments for conservation measures implemented after the Program start date of Monday, November 12, 2013. Applications will be available and accepted on the start date.

ENROLLMENT PROCESS

SOLICITATION AND APPLICATION PROCESS

The program will be launched in November 2013 through an announcement on the SSJID web site and through the SSJID Newsletter mailed to SSJID water users.

Growers are invited to submit applications for one or more fields (Appendix A). For each field, the grower will select one or more conservation measures for implementation from a pre-approved list. Fields will be selected by the District for implementation individually from each application provided that they are complete, pass minimum eligibility requirements, and provided that funding is available, as described in the following sections. Additionally, for some conservation measures (conversion from flood to sprinkler or drip/micro irrigation) the application will be reviewed to ensure compatibility with the SSJID distribution system and operations. The District reserves the right to restrict the amount of participation by a particular grower or a particular field.

As mentioned above, each application must be complete to be considered for inclusion in the Program. A complete application will have all applicable portions of the application filled in and will include sufficient documentation to support evaluation of the conservation measure by the District.

For additional information, contact Program Manager Julie Vrieling at (209) 249-4675 or email jvrieling@ssjid.com.

ELIGIBILITY REQUIREMENTS

The following eligibility requirements apply to all fields applying to enter the Program.

- **Minimum Field Size** – The minimum field size for inclusion in the Program is 10 acres, based on the net irrigated acreage of the field. The 10-acre threshold is additionally the acreage above which the recharge fee applies to fields within the District.

Growers with fields less than 10 acres in size may submit an application. The District will evaluate whether there is sufficient potential for water conservation to be achieved to warrant the administrative time required to include the field in the Program. Proposals to enroll fields less than 10 acres in size will be evaluated on a case by case basis.

- **Current SSJID Water User** – For a field to be eligible for the Program, it must be or become a current SSJID surface water user as a condition to approval of any funding. For physical improvements, the participant agrees to use SSJID surface water for a period of not less than 5 years.

- Water Charges Current – At the time of enrollment, all of the grower’s SSJID water charges must be or become current.
- On-Farm Measurement – For fields entering the Program with pumped deliveries, the participant agrees to install a meter to measure farm deliveries, in accordance with the conservation measure Delivery Measurement for Pumped Deliveries, as described in this document, including any reconfiguration of the pump discharge needed to facilitate accurate measurement while maintaining the pump flow rate. The participant will agree to perform repairs, maintenance, or replacement of water measurement devices as needed to ensure accurate measurement into the future.

The participant agrees to allow SSJID to periodically record flow rate and delivery amounts using the meter and, at the District’s option, to perform repairs, maintenance, or replacement as needed to ensure accurate measurement into the future. Additionally, all participants agree to allow meters to be installed by the District on a case-by-case basis for flood deliveries, if the District determines that site conditions support accurate delivery measurement.

- Satisfactory Performance in Prior Programs – If applicable, applications may be denied due to less than satisfactory performance in prior District programs.
- Cost Share – The District’s maximum share of cost will be a set percentage of the participant’s implementation cost, with maximums put in place.
- Program Award/Modification – the District will review and select applications for participation in the Program based on its determination of which applications best meet the Program objectives. The District may modify the terms for participation in the Program at any time, but will not reduce its commitment applicable to a particular field after a participant has received notice of approval from the District.

SELECTION PROCESS

Fields will be considered on a first-come, first-served basis. An application will be considered approved when the District issues written notice of approval to the applicant at the mailing address or e-mail address specified on the application. The terms of approval and the conditions for District payment will be stated in the notice. Fields will be considered for approval until available funds allocated to each conservation measure of the Program are fully committed for each year, based on the assumption that actual reimbursement costs for cost share payments, as described later in this document, will be the maximum allowable payment per field. If after actual payments are made remaining funds are available, additional fields will be considered in the order in which their applications were received.

In order to encourage adoption of a variety of conservation measures, a total budget will be allocated for each conservation measure as described in the Budget Tracking section of this document.

Approved conservation measures must be completed within 1 calendar year of the date of approval to be considered eligible for cost share payments. Requests for reimbursement must be submitted to the District within the 1 year period. Conservation measures started prior to the approval date are not eligible for cost share payments.

CONSERVATION MEASURES

Conservation measures as described herein are classified as either physical improvements or management practices. Physical improvements include conservation measures involving substantial physical changes to a field. Management practices include collection of information and development of recommendations to aid in improved irrigation management to meet crop water needs.

All measures must be constructed or implemented according to Program standards prior to receiving reimbursement. For physical improvements, all measures must have been inspected and approved by SSJID staff prior to reimbursement. For management practices, payment will be made following the receipt of operational reports (soil moisture monitoring data and/or irrigation scheduling recommendations) under the provision that service provider will provide these data for the full irrigation season for which the field is enrolled in the Program. For both physical improvements and management practices, documentation of costs must be provided to the District's satisfaction prior to reimbursement.

As described in the Background and Overview section of this Program Description, for the 2014 Program, participants will be eligible for cost share payments for conservation measures implemented after the Program start date of November 12, 2013.

PHYSICAL IMPROVEMENTS

Delivery Measurement for Pumped Deliveries

Delivery measurement for pumped deliveries consists of installing a flow meter to measure SSJID water deliveries for existing or new pumped SSJID deliveries. In some cases, the existing pump discharge piping may need to be reconfigured to provide an adequate straight section of pipe without bends or other obstructions to allow for accurate flow measurement using a flow meter.

This conservation measure is applicable to any case in which SSJID water is delivered to a pump that pressurizes irrigation water for application via a sprinkler, drip, or micro system. Minimum standards for the measure are:

- Seametrics AG2000 Irrigation Magmeter, McCrometer Ultra Mag flow meter, or approved equal
 - Installed with at least 3 diameters of straight pipe upstream of meter and 2 diameters of straight pipe downstream of meter (see Figure C-1)
 - Provided with continuous power supply
 - Equipped with telemetry hardware allowing integration to the District's Supervisory Control and Data Acquisition (SCADA) System
 - Equipped with an internal datalogger¹⁵
- The participant agrees to perform repairs, maintenance, or replacement of water measurement devices as needed to ensure accurate measurement into the future.
- The participant agrees to allow the District to record delivery flow rates and volumes periodically for the life of the meter and to allow the District, at its option, to perform any repair, maintenance, or replacement, as needed to ensure accurate measurement into the future.
- The land owner must sign an SSJID agricultural Meter Service Agreement (Appendix C) as part of implementation of this conservation measure.
- The participant agrees to allow the District, at its option, to install telemetry, including but not limited to a solar panel, mast, antenna and other necessary equipment to remotely monitor delivery flows using the flow meter.

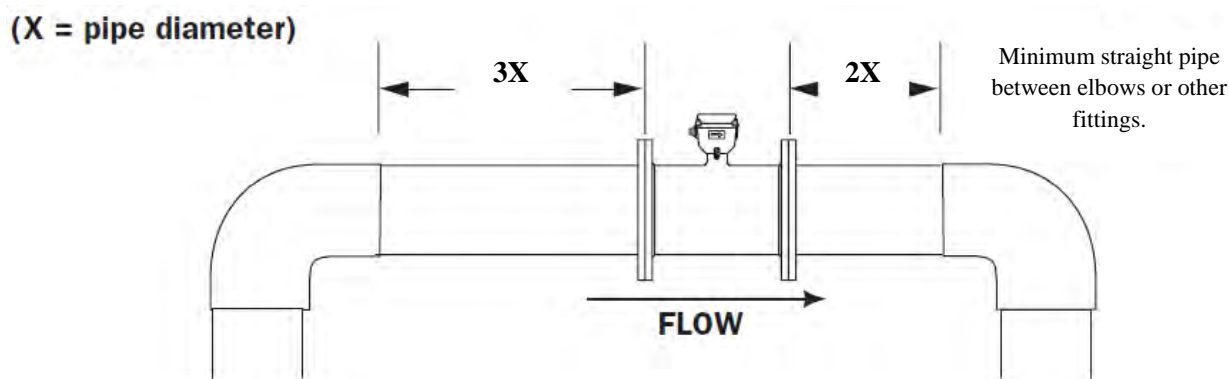

Figure C-1. Example Magnetic Flow Meter Installation.

This measure will be included with any participating fields installing a sprinkler or drip irrigation system as described under the following conservation measure. All growers implementing this measure are required to agree to allow the District to read the flow meter periodically for purposes of delivery record keeping for the life of the device.

¹⁵ An external datalogger is required and is subject to approval by SSJID.

The estimated cost for planning purposes is \$5,650 per location based on the estimated purchase and installation cost of a 12” mag meter, plus a contingency to allow for re-plumbing of pipe discharge to allow for adequate length of straight pipe to install the meter in some cases.

The District’s cost share for delivery measurement of pumped deliveries will be 80% of the actual cost, not to exceed \$4,500.

Conversion from Flood to Sprinkler or Drip/Micro Irrigation

Conversion from flood to sprinkler or drip irrigation consists of installing a sprinkler, drip, or microspray irrigation system on an existing field that is currently flood irrigated. The conservation measure includes installation of the pump, filtration, mainlines, laterals, and emitters for the system. Adoption of this conservation measure additionally includes and requires installation of an SSJID approved sump to allow for pumping of canal water along with adoption of the conservation measure Delivery Measurement for Pumped Deliveries, described previously.

Conversion from flood to sprinkler or drip irrigation is generally applicable throughout SSJID, except where delivery system physical and operational constraints limit the District’s ability to meet the delivery needs of sprinkler or drip/micro systems. Although the primary crops currently irrigated using sprinkler or drip irrigation are trees and vines, this conservation measure could also apply to the installation of a sprinkler system to irrigate pasture or field crops, for example. **Applications for conversion to sprinkler or drip/micro irrigation will be evaluated on a case by case basis to determine whether the District can continue to provide canal water to meet crop water needs following irrigation system conversion. Only fields located such that the District can supply surface water at the flow rate and irrigation intervals required after conversion will be approved.**

Minimum standards for this measure have been identified based on the NRCS Conservation Practice Standards listed in Table C-1, below. These standards are included in Appendix B of this document.

Table C-1. NRCS Conservation Practice Standards Applicable to Conversion from Flood to Sprinkler or Drip Irrigation.

NRCS Conservation Practice Standard	Applies to Conversion from Flood to:	
	Sprinkler	Drip or Micro
Irrigation System, Sprinkler (442)	<input type="checkbox"/>	
Irrigation System, Microirrigation (441)		<input type="checkbox"/>
Pumping Plant (533)	<input type="checkbox"/>	<input type="checkbox"/>
Irrigation Pipeline (430)	<input type="checkbox"/>	<input type="checkbox"/>

Additionally, the following requirements developed by SSJID shall apply:

- No filters may back flush to District pipelines or open canals
- Each system must be designed by an Irrigation Association Certified Irrigation Designer
- Design Distribution Uniformity must be at least 75% for sprinkler systems and at least 90% for drip or micro systems
- Participants are responsible for submitting an Application for Structure Permit and constructing a District-approved sump prior to receiving reimbursement for system installation costs under this conservation measure.

The estimated cost for conversion from flood to sprinkler or drip/micro for planning purposes is \$1,650 per cropped acre based on estimated materials and installation costs of a complete system including pump, filtration, mainlines, laterals, and emitters. The estimated costs are based on discussion with local irrigation suppliers and review of NRCS EQIP cost estimates. Sump costs are considered inclusive to the irrigation system and will be reimbursed through this Conversion conservation measure. Reimbursement for flow meter costs will be made separately under the Program based on the Delivery Measurement for Pumped Deliveries conservation measure, described previously.

The District's cost share for conversion from flood to sprinkler or drip irrigation will be 50% of the actual cost, not to exceed \$825 per cropped acre. Additionally, the cost share payment will be limited to a maximum of \$25,000 per grower for each measure. As described, this cost share does not include delivery measurement for pumped deliveries, which will be treated separately.

Drainage Relief Option

This conservation measure includes tailwater recovery systems, land leveling, and the modifying of discharge valves.

Tailwater Recovery Systems to Prevent Runoff consist of systems to collect and convey tailwater to the head of the field from which the tailwater was generated or another nearby field for the purpose of recovering and reapplying the tailwater to supplement irrigation deliveries. For this Program, tailwater recovery systems are targeted at fields that periodically drain tailwater back into the SSJID distribution system where it currently is delivered to a downstream user or spills from the system. SSJID discourages and in the future may no longer allow drainage of tailwater into the distribution system. This conservation measure applies to any field for which tailwater is produced during irrigation that drains back to the SSJID irrigation system. It is anticipated that this only occurs for flood irrigated fields.

Minimum standards for tailwater recovery systems have been identified based on the NRCS Conservation Practice Standards for Irrigation System, Tailwater Recovery (447), Pumping Plant (533), and Irrigation Pipeline (430), included in Appendix B of this document.

The estimated cost of tailwater recovery systems for planning purposes is \$1,200 per cropped acre based on estimated materials and installation costs of a complete system including tailwater pond, tailwater return pipeline, and pump. The estimated costs are based on estimated quantities and unit costs for system components and based on review of NRCS EQIP cost estimates.

The District will also consider laser land leveling, deep ripping, as well as the modification of discharge valves to reduce drainage into the SSJID distribution system. Minimum standards for laser land leveling and deep ripping have been identified based on the NRCS Conservation Practice Standards for Irrigation System, Precision Land Forming (462), Irrigation Land Leveling (464), Land Smoothing (466) and Deep Tillage (324), included in Appendix B of this document.

The District's cost share for drainage relief options will be 50% of the actual cost, not to exceed \$600 per cropped acre. Additionally, the cost share payment will be limited to a maximum of \$10,000 per grower for this measure.

MANAGEMENT PRACTICES

Scientific Irrigation Scheduling & Soil Moisture Monitoring

Scientific Irrigation Scheduling consists of the determination of the frequency, rate, and duration of irrigation application needed to meet crop water requirements while minimizing excess tailwater and deep percolation. Typically, this determination is based on a combination of soil moisture monitoring and root zone water balance calculations based on estimates of crop water use (evapotranspiration, or ET). Scientific irrigation scheduling is applicable to all irrigated crops, regardless of irrigation system type or soil conditions.

In most cases, the optimum frequency, rate, and/or duration of irrigation is constrained by available water supply, the delivery system, the soil, or the irrigation system itself. In the case of SSJID, the delivery frequency and flow rate are generally fixed under current system operation, providing flexibility almost exclusively in the duration of irrigation.

Soil Moisture Monitoring consists of tracking the moisture content of the crop root zone over the course of the growing season to evaluate whether irrigation practices are sufficient to maintain adequate soil moisture content while limiting excess deep percolation. Soil moisture monitoring is a key component of scientific irrigation scheduling and is applicable to all irrigated crops, regardless of irrigation system type or soil conditions. For the Program soil moisture monitoring is offered to assist growers in tracking soil water content, or it may be implemented as part of scientific irrigation scheduling, described previously.

Under the Program, the District requires that scientific irrigation scheduling and soil moisture monitoring be conducted by approved service providers using proven technologies. Additionally, the District requires that irrigation recommendations and/or duplicate soil moisture

monitoring reports be submitted to both the participating grower and to the District by the service provider.

The estimated cost of scientific irrigation scheduling for planning purposes is \$3,000 per field per season. The estimated cost of soil moisture monitoring for planning purposes is \$1,500 per field per season. These costs represent the average seasonal cost for a consulting service to provide irrigation recommendations or provide soil moisture monitoring reports for an individual field based on discussion with consultants serving the San Joaquin Valley. The difference in cost between consultants depends largely on whether continuously recording soil moisture monitoring equipment is installed in the field; costs will likely be substantially less for weekly field visits using portable soil moisture monitoring equipment.

Unlike physical improvements, the District will pay a portion of the total cost of the scientific irrigation scheduling service and/or soil moisture monitoring service directly to the service provider. The portion that the District is willing to pay will be a one-time payment of 50% of the actual cost, not to exceed \$1,125 per field. The maximum payment for Scientific Irrigation Scheduling and/or Soil Moisture Monitoring will be limited to \$2,500 per grower.

DISTRICT SERVICES

Valve Packing

Valve packing is a service that was traditionally provided by the District to repack irrigation valves to reduce valve leakage. Valve packing is applicable wherever large flood irrigation valves installed on District pipelines are used. Growers are to make arrangements to have their valves packed by contacting Julie Vrieling at (209) 249-4675 or e-mail jvrieling@ssjid.com. District staff will repack the valves. Valves will be packed according to manufacturer specifications, if applicable.

Growers will be charged a fee for valve packing to cover District labor and materials costs for repacking the valves. Additionally, the grower is responsible for the removal and reinstallation of the valve, as well as delivery to and pickup from the District. The District may restrict the availability of this service depending on the availability of personnel.

MAXIMUM COST SHARE PAYMENT PER GROWER

In addition to the payment limitations described previously for each conservation measure, the total cost share for 2014 for all fields enrolled by a grower will be limited to \$25,000.

INTERACTION WITH OTHER, NON-DISTRICT PROGRAMS

Other Programs may provide cost share payments for implementing conservation measures included in this Program. For example, programs offered by the Natural Resources Conservation

Service of the USDA, such as the Environmental Quality Incentives Program (EQIP), offer cost share of 50% (or more in some cases) to cover the cost of installing sprinkler systems, drip/micro systems, tailwater recovery systems, or other on-farm improvements.

Participation in the SSJID On-Farm Water Conservation Program does not prevent growers from participating in EQIP or other Federal programs. Similarly, participation in EQIP or other Federal programs does not prevent participation in the SSJID On-Farm Water Conservation Program.

PAYMENT APPROVAL AND PROCESSING

Upon receipt of a request for payment and documentation showing actual payment of the incurred conservation measure implementation costs from an approved applicant, the District will verify that the measure has been implemented (as described in the following section) and payment will be issued based on the Program cost share percentage for the measure or measures implemented and based on the actual cost, not to exceed the cost share limit for the measure or measures.

Requests for reimbursement must be accompanied by documentation of implementation costs, including invoices and receipts from equipment and service providers, along with proof of payment. Costs incurred by the grower internal to his or her operation that are associated with the installation of the conservation measure are not considered eligible for reimbursement.

Payments will be issued as a separate check to the participating grower, rather than as a reduction in water charges. It is anticipated that payment will be made within 30 days of the District's verification that the measure was implemented.

MONITORING AND VERIFICATION

Monitoring and verification of implementation of conservation measures will be accomplished through a combination of documentation of implementation costs (receipts and payments) and operational reports (flow measurement records, soil moisture monitoring reports, and irrigation recommendations), along with field visits to verify that physical improvements are implemented according to Program standards. Additionally, the District will seek feedback from participating growers in the form of interviews or questionnaires with the objective of evaluating the Program and documenting changes to irrigation practices resulting from conservation measure implementation.

APPENDIX A: APPLICATION FOR PROGRAM PARTICIPATION

Intentionally Left Blank

For District Use Only

Date Received: _____

APPLICATION FOR ON-FARM WATER CONSERVATION PROGRAM

-
-
1. Applicant/Landowner name _____ email _____
 2. Mailing address _____
 3. Telephone # _____
-
-

Complete one application for each field to be included in the Program. All measures must be implemented after the application approval date and completed within 1 year to be eligible for reimbursement.

SUBMIT COMPLETED APPLICATION TO SSJID

-
1. A detailed design plan and cost estimate must be submitted with applications including physical improvements to a field.
 2. Your application will be reviewed and processed according to District policy and as described in the Program Description. A determination will be made as to the eligibility and potential effectiveness of the proposed conservation measure or measures for each field, and a recommendation will be made to the General Manager, Jeff Shields.
 3. Following review, you will be sent a letter or e-mail summarizing the conservation measures approved for implementation for each field application and providing explanation of why any fields or conservation measures were not approved, if applicable.
 4. **COST SHARE PAYMENTS ARE NOT GUARANTEED UNTIL YOUR APPLICATION HAS BEEN APPROVED.**
 5. If you have any questions concerning your Application please feel free to contact Julie Vrieling at (209) 249-4675 or email jvrieling@ssjid.com.
 6. By signing below, you agree to implement the conservation measures described in this application and to abide by all Program requirements as described in the Program Description.

APPLICANT/LANDOWNER SIGNATURE _____

DATE _____

APPLICATION FOR ON-FARM WATER CONSERVATION PROGRAM (CONTINUED)

BASIC INFORMATION

1. Applicant/Landowner name _____
2. Assessor's Parcel Number (APN) _____
3. SSJID Delivery Location (example: Lat. Wc, St. 120) _____
4. Field size¹ (acres) _____
6. Crop _____

PROPOSED PHYSICAL IMPROVEMENTS

1. Delivery Measurement for Pumped Deliveries _____
2. Conversion from Flood to Sprinkler or Drip/Micro Irrigation¹ _____
3. Drainage Relief Option _____

PROPOSED MANAGEMENT IMPROVEMENTS

1. Scientific Irrigation Scheduling or Soil Moisture Monitoring _____

Have you applied for funding for these conservation measures under any other programs, such as NRCS EQIP? Yes ___ No ___

APPLICANT/LANDOWNER SIGNATURE _____ DATE _____

Preferred method of contact: E-mail _____ Postal Mail _____

¹ Fields less than 10 acres in size will be considered for participation on a case-by-case basis based on the potential to achieve water conservation as described in the Program Description.

¹ Conversion from flood to sprinkler or drip/micro must include the delivery measurement for pumped deliveries conservation measure.

APPENDIX B: APPLICABLE NRCS CONSERVATION PRACTICE STANDARDS

The following NRCS Conservation Practice Standards are attached:

1. Irrigation System, Sprinkler (442)
2. Irrigation System, Microirrigation (441)
3. Pumping Plant (533)
4. Irrigation Pipeline (430)
5. Irrigation System, Tailwater Recovery (447)
6. Precision Land Forming (462)
7. Irrigation Land Leveling (464)
8. Land Smoothing (466)
9. Deep Tillage (324)

Intentionally Left Blank

**APPENDIX C: CONSENT TO SOUTH SAN JOAQUIN IRRIGATION
DISTRICT'S ENTRY OF PROPERTY TO READ AND OWNER'S
AGREEMENT TO MAINTAIN FLOW METER**

Intentionally Left Blank

AFTER RECORDING RETURN TO:

SOUTH SAN JOAQUIN IRRIGATION DISTRICT
P.O. BOX 747
RIPON, CA 95366

CONSENT TO
SOUTH SAN JOAQUIN IRRIGATION DISTRICT'S
ENTRY OF PROPERTY TO READ
AND TO MAINTAIN FLOW METER

Exempt from all Recording Fees: California Government Code §§6103; 27388.1(a)(1)
Documentary Transfer Tax: NONE (Revenue & Taxation Code §§1911, 1922)

The undersigned Owner, _____, of the property located at _____, APN _____ ("Property") and further described in the attached Exhibit "A", has, with the approval of SOUTH SAN JOAQUIN IRRIGATION DISTRICT ("District"), installed a flow meter to measure deliveries of District surface water to the Property. The District will use flow meter measurements to implement state law that requires the District to base its water charges, at least in part, on the quantity of water it delivers.

Owner consents to the entry of District officers, employees or agents ("District Personnel") on the Property for the purposes of inspecting, maintaining and reading the flow meter installed to measure deliveries of District surface water to the Property. District Personnel may enter the Property at any reasonable hour and on a monthly basis or at such other time as District reasonably determines to be necessary, to inspect the working condition of the meter, to maintain the meter and to record water usage. District shall also be permitted to enter the Property for the purpose of installing and maintaining telemetry control hardware to the meter such that the meter can be read remotely. District Personnel may enter the Property outside any District easement area using marked District vehicles on available access roads, on foot or as Owner and District may otherwise agree. District shall use reasonable care to avoid interfering with Owner's farming operations.

Owner agrees to take no action that would prevent the meter from accurately measuring the volume of District surface water delivered to Owner's Property.

This Consent shall remain in effect until such time as deliveries of District surface water to the Property shall terminate as evidenced by recordation of an Irrigation Service Abandonment Agreement signed by District and Owner or Owner's successor in interest.

This Consent shall run with the land described above and be binding on Owner and Owners' heirs, successors and assigns.

SOUTH SAN JOAQUIN IRRIGATION DISTRICT
"DISTRICT"

By _____ Date: _____

Robert Holmes, President
Board of Directors

By _____ Date: _____

Peter M. Rietkerk, Secretary
Board of Directors

"OWNER(S)"

By _____ Date: _____

By _____ Date: _____

Mailing Address: _____

Phone Number: _____

SIGNATURES MUST BE NOTARIZED AND BE PER RECORDED DEED

EXHIBIT “A”

Legal Description

Intentionally Left Blank

APPENDIX D. SOUTH SAN JOAQUIN IRRIGATION DISTRICT DROUGHT MANAGEMENT PLAN

Intentionally Left Blank

BACKGROUND AND OVERVIEW

Since its formation in 1909, SSJID has faced variability in surface water supplies due to drought, and recognizes that there may be times when available surface water supplies are insufficient to fully meet crop water demands. leading to the development of SSJID’s current and past water shortage contingency actions. These measures allow SSJID to effectively manage drought-limited water supplies while still upholding the District’s obligation to manage and deliver water in a reasonable and beneficial manner and its desire to provide equitable water delivery service.

On April 1, 2015 Governor Brown issued Executive Order B-29-15, mandating agricultural water suppliers to include a detailed Drought Management Plan (DMP) describing actions and measures taken to manage water demand during drought in their 2015 Agricultural Water Management Plan (AWMP) update. In response to the Governor’s Executive Order, SSJID developed a detailed description of existing policies and extraordinary actions undertaken in response to drought conditions for the District’s 2015 AWMP. Three years later, Assembly Bill 1668 (AB 1668) was passed on May 31, 2018. AB 1668 amended the California Water Code (CWC) and requirements for AWMPs, providing more detail on the specific requirements of a Drought Plan, or DMP (CWC 10826.2). This DMP expands upon SSJID’s long-standing water shortage contingency actions, specifically describing the District’s (1) drought resiliency planning actions undertaken to prepare for drought, and (2) drought response actions undertaken to manage available water supplies and to meet customer demands to the maximum extent possible.

The 2020 DMP includes all components that are required by CWC 10826.2 and that are recommended by DWR in its 2020 AWMP Guidebook (DWR 2020). Additionally, the 2020 DMP reflects on the impacts of the 2012-2016 drought.

DROUGHT RESILIENCE PLANNING (§10826.2(A))

This section describes actions and activities undertaken by SSJID to prepare for drought and effectively manage and mitigate the effects of surface water shortage. It includes the determination of water supply availability and drought severity, identification and analysis of potential vulnerability to drought, and opportunities and constraints for improving drought resiliency planning.

DETERMINATION OF WATER SUPPLY AVAILABILITY AND DROUGHT SEVERITY (§10826.2(A)(1))

Monitoring hydrologic conditions to assess available water supplies is at the core of SSJID’s water management strategy. To inform decisions related to available water supply, SSJID actively monitors water supply conditions, including inflow projections from the Bureau of Reclamation (Reclamation) for New Melones Reservoir. Through its various operations and

planning efforts, SSJID also monitors precipitation and snow forecasts and accumulations, runoff, reservoir storage, groundwater levels, and instream flows.

SSJID's surface water supply depends primarily on water year inflow to New Melones as stipulated in a 1988 agreement with Reclamation. SSJID and neighboring Oakdale Irrigation District entered into an agreement with Reclamation on how water was to be allocated between the districts and Reclamation. Under the 1988 Agreement, the Districts are collectively entitled to receive the first 600,000 acre-feet per year, and in years when inflow to New Melones is less than 600,000 acre-feet, the Districts are entitled to receive the actual inflow plus one-third of the difference between 600,000 and the actual inflow. Water that is unused in any one year may be stored at New Melones in a "conservation account," up to a total of 200,000 acre-feet and can be used in certain water short years.

The District receives daily morning reports from Tri-Dam summarizing current water supply availability, weather conditions, and power generation. SSJID utilizes these reports to develop a projected water budget. An example Tri-Dam report and projected water budget is provided in Attachment D-1.

Groundwater conditions are reported through the San Joaquin County Flood Control and Water Conservation District, which has monitored and published reports on groundwater levels and groundwater quality across Eastern San Joaquin County since 1971. The Groundwater Reports utilizes data from federal, state and local government agencies as well as non-governmental sources. Over 550 wells, of which 270 are measured by County staff, are included in the Monitoring Program. Groundwater level data are collected and reported on a semi-annual basis, during the months of April and October, to observe groundwater levels before and after peak groundwater pumping conditions. Groundwater quality measurements are sampled once per year in the fall months, after peak groundwater production in the summer, and are made available in the Fall Groundwater Report. These reports are available online at: <http://www.sjwater.org/Groundwater/Groundwater-Reports>.

Additionally, the Eastern San Joaquin Groundwater Authority is responsible for producing an annual GSP report to satisfy SGMA requirements. SSJID through the SSJGSA provides data to the report.

POTENTIAL VULNERABILITY TO DROUGHT (§10826.2(A)(2))

Generally, SSJID's water supplies have been sufficient in all but the driest years due to its secure and reliable surface water supply from the Stanislaus River watershed. The District's use of surface water is based on pre-1914 adjudicated and post-1914 appropriative rights that are shared with OID, with the exception of rights applicable to Woodward Reservoir, which are solely owned by the SSJID.

After the construction of New Melones Reservoir by the U. S. Bureau of Reclamation (USBR), the District entered into an agreement with the USBR describing how water was to be allocated between SSJID, OID, and the USBR. Under the 1988 Agreement, SSJID and OID are entitled to receive the first 600,000 acre-feet per year, and in years when inflow to New Melones is less than 600,000 acre-feet, are entitled to receive the actual inflow plus one-third of the difference between 600,000 and the actual inflow. Water that is unused in any one year may be stored at New Melones in a “conservation account,” up to a total of 200,000 acre-feet, and can be used in certain water short years, helping to protect SSJID from vulnerability to drought. Surface water is also stored or regulated in the Beardsley, Donnells, Tulloch, and Woodward Reservoirs.

In the majority of years, SSJID is provided its full allotment of 300,000 af from New Melones Reservoir, per the 1988 Agreement. Over the 15-year period between 2005 and 2019, SSJID received a partial allotment in only 6 years. As described in Section 4.1 of the 2020 AWMP, surface water accounts for about 70 to 80 percent of SSJID’s total water supply in most years.

In years when partial allotments are provided to SSJID, both the District and private landowners have access to groundwater production wells that serve primarily to supplement surface water supplies. Seepage and deep percolation of SSJID’s surface water supply serves as a major source of recharge to the groundwater system, providing a supply for drought years and regional benefits to groundwater pumpers as well. This is described in more detail in Section 4.3 of the 2020 AWMP. SSJID’s conjunctive management of surface water and groundwater resources is foundational to protecting its customers and others in the Subbasin from drought vulnerability. SSJID has also partnered with the Cities of Ripon and Escalon to form the South San Joaquin Groundwater Sustainability Agency (SSJGSA), which is responsible for groundwater management in its area of the Eastern San Joaquin Groundwater Subbasin. Through the SSJGSA, SSJID has joined with other GSAs to form the East San Joaquin Groundwater Authority (ESJGWA) to develop a single Groundwater Sustainability Plan (GSP) for the Subbasin. This plan was submitted to DWR ahead of the January 31, 2020 deadline, and outlines a path toward groundwater sustainability in the Subbasin by 2040. Ongoing implementation of the GSP provides support for ongoing conjunctive use of surface water and groundwater supplies in the Subbasin and for enhanced drought resilience in the future.

Figure D-1 shows the total water supplies available to SSJID. Surface water inflows include deliveries from the Joint Supply Canal. Groundwater inflows include pumping from both District-owned and privately-owned groundwater wells. Other supplies include OID spillage, stormwater runoff, and tributary inflows that enter SSJID’s canals and drains.

The total water supply volume (surface water, groundwater, and other water supply) is generally consistent, ranging from approximately 260,000 to 330,000 af per year, even during the 2012-2016 drought – the driest four-year period in SSJID’s history. The irrigation season length is also fairly consistent from year to year, averaging over 220 days per season between 2005-2019.

During the 2012-2016 drought, the season length was generally only slightly shorter than average except in 2014, when the irrigation season was three weeks shorter.

The general consistency of SSJID’s water supply and season length, even during historic drought conditions, suggests that SSJID is well-protected against drought vulnerability.

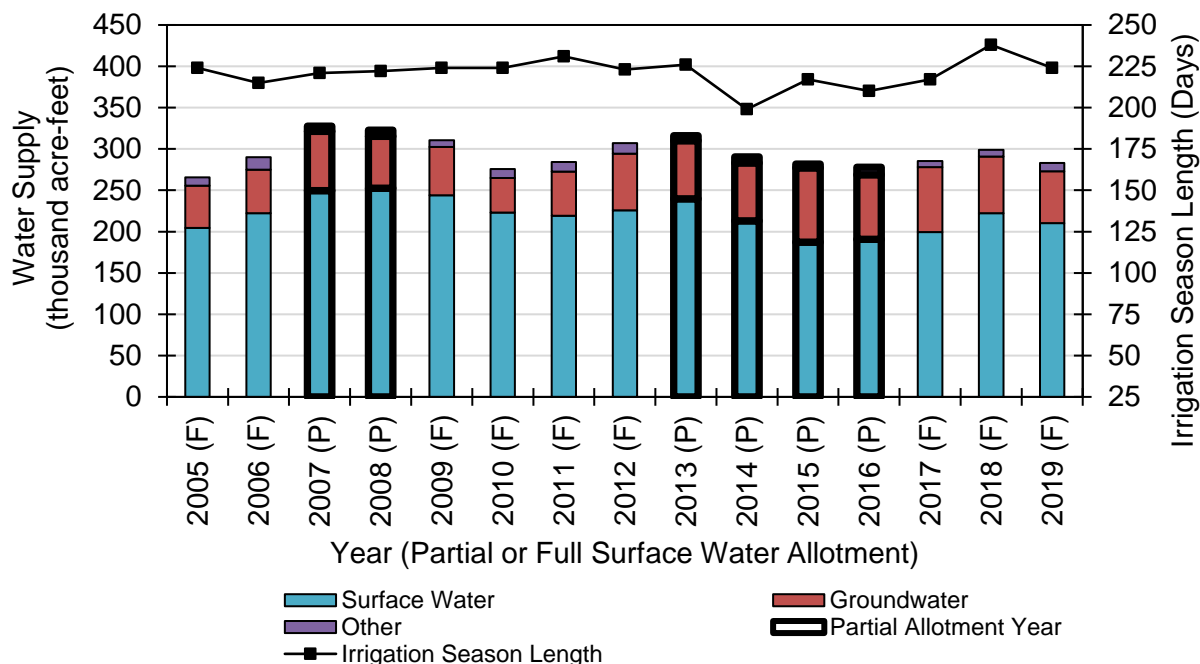

Figure D-1. SSJID Total Water Supply and Irrigation Season Length, 2005-2019.

DROUGHT RESILIENCE OPPORTUNITIES AND CONSTRAINTS: AVAILABILITY OF NEW TECHNOLOGY OR INFORMATION (§10826.2(A)(3)(A))

SSJID has prioritized implementation of new technology and improvements in data collection and monitoring for many decades. In recent years, SSJID has also made substantial, long-term improvements to distribution system infrastructure, data tools, and operational practices that have increased operational efficiency and improved SSJID’s drought resilience. Several highlights of SSJID’s activities are described below and in Section 7 of the 2020 AWMP:

- Online account access for growers since 2013, allowing growers to view their water usage from anywhere.
- On-farm meter portal since 2018, allowing growers to view real-time flows
- Use of a SCADA system for automating the Main Distributary Canal (MDC) and select system infrastructure, and for monitoring canal flows, deliveries, spillage, and drain boundary outflows

- Implementation of the System Improvements for Distribution Efficiency (SIDE) Project in 2003, resulting in increased flexibility for system operations and deliveries in the surrounding area
- Implementation of the Irrigation Enhancement Project (also known as the Division 9 Project) in 2012, resulting in the availability of pressurized water for irrigators with arranged demand and online ordering, also reducing reliability on groundwater of lesser quality
- Initiation of planning for a Water Information System (WIS), and preparation of a conceptual plan to develop the WIS to improve data management

SSJID plans to continue implementing new technologies to improve drought resiliency and operational efficiency and is continually exploring new technologies and information to achieve these ends. The largest impediment to implementing new technologies and disseminating information is cost, which can be restrictive to implementation in some cases.

DROUGHT RESILIENCE OPPORTUNITIES AND CONSTRAINTS: AVAILABILITY OF ADDITIONAL WATER SUPPLIES (§10826.2(A)(3)(B))

As described previously, SSJID's water supplies have generally been sufficient in all but the driest years through conjunctive management of surface water and groundwater supplies combined with drought management actions.

SSJID utilizes available recycled water and drainage water to supplement primary water supplies. Between 2005-2019, an average of 9,000 af of other supplies entered SSJID canals, laterals, and drains each year. A portion of this is available to supply deliveries. The District is open to receiving recycled wastewater for irrigation purposes if it is technically feasible and locally cost effective for all stakeholders. The District will continue to consider additional opportunities to increase available water supply to enhance the District's drought resiliency.

DROUGHT RESILIENCE OPPORTUNITIES AND CONSTRAINTS: OTHER PLANNED ACTIONS (§10826.2(A)(3)(C))

The District plans to continue evaluating opportunities to reduce potential vulnerability to drought. As opportunities are identified, planning efforts will incorporate feasibility studies, scoping, and implementation timelines for feasible opportunities.

As described in Section 7.4.8 of the 2020 AWMP, SSJID implements conjunctive use by encouraging the use of available surface water supplies, when available, in lieu of groundwater by (1) actively facilitating delivery service to customers using pressurized irrigation systems, and (2) providing surface water at an affordable rate lower than the cost of pumping groundwater. These actions conserve groundwater for pumping in years of limited surface water availability and by neighboring water users such as the cities of Manteca, Lathrop, Ripon, and Escalon

SSJID’s conjunctive management objectives support drought resilience by: 1) maintaining a sustainable groundwater system through continued use of surface water for deliveries and recharge in normal and wet years, and 2) maintaining water deliveries in dry years through groundwater pumping.

Throughout the District, SSJID’s DMs work to meet the evolving needs of customers that increasingly use high-frequency, long duration, low flow rate irrigation systems, such as microirrigation and sprinklers. SSJID is able to provide many of these customers with surface water deliveries, providing in-lieu recharge thanks to DMs’ skilled efforts and the technologies that SSJID has deployed over time to enhance monitoring and control of the system. Divisions with high concentrations of pressurized irrigation systems are generally able to successfully provide arranged-demand delivery within operational constraints.

Additionally, SSJID has implemented its Irrigation Enhancement Project (also known as the Division 9 Project) which provides pressurized surface water for irrigation of over 3,800 acres. Many of the parcels within the project area that were previously irrigated exclusively with groundwater are now connected to the pressurized surface water, further supporting conjunctive use.

SSJID’s water rates are kept low for affordability and to also encourage the use of available surface water supplies in lieu of groundwater. The District’s pricing structure, described in Section 3.9 of the 2020 AWMP, is an important part of SSJID’s overall strategy of conjunctive management of surface water and groundwater supplies to maintain long term water supply.

As a member of the South San Joaquin GSA, SSJID was actively involved in developing the Eastern San Joaquin Groundwater Subbasin GSP, which outlines a path toward groundwater sustainability in the Subbasin by 2040. Ongoing implementation of the GSP provides support for ongoing conjunctive use of surface water and groundwater supplies in the Subbasin and for enhanced drought resilience in the future.

One additional action to promote drought resilience, which has been implemented in the past and which SSJID continues to implement, is encouragement of on-farm water stewardship to support drought resilience. Specific actions taken by SSJID include:

- Education and Outreach to Growers
- Enforcement of SSJID Rules and Regulations
- Volumetric Pricing

These actions are described in the 2020 AWMP, and summarized below.

Education and Outreach to Growers

SSJID regularly provides educational resources and conducts outreach activities to support efficient water management by its irrigation customers. Specific resources include:

- SSJID’s “Irrigation Newsletter,” with information for growers about the irrigation season, proposed projects, updates regarding District planning efforts, and educational opportunities
- The District’s “Agriculture / Irrigation Water” webpage (<https://www.ssjid.com/district-services/agriculture-irrigation-water/>), with tips and information on water management, water conservation, and SBx7-7 compliance efforts
- The District’s “News” webpage (<https://www.ssjid.com/news/>), with links to official publications, press releases, and information about our various ongoing projects by the District
- The District’s “Education” webpages (for example, <https://www.ssjid.com/education/for-teachers/>), with resources for children and teachers that discuss water safety, the importance of water for the community and for agriculture, and topics related to water conservation and hydropower.

SSJID’s resources and tools teach customers and the public about water, hydropower, conservation, and many other related topics, supporting overall understanding of water management and drought resilience.

Enforcement of SSJID Rules and Regulations

In all years, SSJID enforces its “Rules and Regulations for Governing the Distribution of Water in the South San Joaquin Irrigation District” (Rules and Regulations) to ensure that all water is applied efficiently and is used in a reasonable and beneficial manner.

The Rules and Regulations govern SSJID’s control of system facilities, employee conduct, apportionment of water, rotation of water, irrigation time limits, continuous use of water, deliveries, control, waste of water, access to land, breaks, use of rights-of-way, unlawful acts, and enforcement and modification of rules. By enforcing these control measures, SSJID actively supports drought resilience.

Volumetric Pricing

As described in Sections 3.9 and 7.3.2 of the 2020 AWMP, SSJID first adopted a volumetric pricing structure in 2012. In accordance with SBx7-7, SSJID’s current volumetric pricing structure is based in part on the volume of water delivered, with a volumetric charge for water delivered in addition to a flat rate charge (per acre served). Two tiers of volumetric pricing are used for growers that receive non-pressurized water service. The “Tier 1” rate is lower, and is used to bill growers that receive less than 48 inches per year. The “Tier 2” rate is higher, and is used to bill growers for any volume of water in excess of 48 inches per year. This pricing

structure supports drought resilience by encouraging both surface water use when available and prudent use of water resources by irrigators.

DROUGHT RESPONSE PLANNING

This section describes actions and activities undertaken by SSJID in response to drought to address surface water shortage. It incorporates a discussion of the shortage allocation policies described in Section 3.10 of the District's 2020 AWMP, as well as other coordination, collaboration, and supply management that occur during drought.

POLICIES AND PROCESSES FOR WATER SHORTAGE DECLARATION AND WATER SHORTAGE ALLOCATION AND IMPLEMENTATION (§10826.2(B)(1))

The District's water shortage allocation policies are described in Section 3.10 of the 2020 AWMP.

During periods of surface water shortage, the District's Board of Directors determines and implements a strategy to reduce surface water diversions based on staff recommendations. In a reduced water supply year, SSJID Board sets specific water allocation policies and implements other management actions based on current conditions.

The SSJID Board of Directors developed and adopted a set of special rules to be implemented in case of a water supply emergency. The rules, first developed and adopted in the spring of 1991, were intended to maintain equitable service even in the event of a water shortage. In 2012, the District's Agricultural Water Committee reviewed the 1991 rules and summarized a set of contingency actions for Board consideration. The resulting contingency plan and "special rules" are not permanent documents and may vary in specific provisions over time based on Board policies.

The surface water shortage contingency actions established in 2012 are summarized in eight measures that have been implemented by SSJID in past shortages and can be implemented in the event of a future shortage while still upholding its obligation to manage and deliver water in a reasonable and beneficial manner and to provide equitable service. These contingency actions are summarized as follows:

- Reduce the maximum water surface elevation of Woodward Reservoir to minimize surface evaporation and seepage
- Delay the start date of the irrigation season
- Implement a variable water delivery rotation schedule
- Implement maximum time limits for flood irrigation
- Implement irrigation quantity limits

- Implement alternative supply sources (e.g. lease private pumps, use District wells, or possibly drill additional wells)
- Allow for inter-parcel transfers with a cut-off date for transfers. Those requesting transfers must apply before the start of the year's irrigation season.
- Enforce Tier 2¹⁶ service agreement provisions

Due to decreasing reservoir inflow, the District's water supply from New Melones decreased over the four consecutive years of 2012 to 2015. In 2015, the District adopted a 36 inch per parcel allocation to limit irrigation water deliveries and preserve available surface water supply. In addition to agricultural water supply curtailments, surrounding municipalities which receive water from SSJID were also cut back to 20% of historical deliveries per Governor's orders. The District also stopped supplying water trucks and poly-tanks used in construction for dust control.

METHODS AND PROCEDURES FOR TRIGGERING AND ENFORCING WATER SHORTAGE RESPONSE ACTIONS (§10826.2(B)(2))

SSJID does not rely on mechanistic, pre-determined triggers to implement drought management actions. Rather, the Board of Directors considers data regarding current and projected water supply conditions as well as recommendations from SSJID staff to determine whether surface water shortage contingency actions should be triggered. Based on Board decisions influenced by the amount of water available each year, water policies are modified and drought management actions are implemented and adjusted as needed. This approach to managing water supplies and demands during shortages allows SSJID flexibility to maximize the long term reliability, quality, and affordability of irrigation water supplies. Continued investments in automated irrigation system management and measurement have allowed SSJID to become more sophisticated in serving its customers and meeting irrigation demands with less water.

During drought periods, SSJID enhances the enforcement of its Rules and Regulations. In 2015, SSJID released six 'Emergency Drought Bulletins' to inform the general public and customers regarding the severity of the drought, actions the District was taking to conserve water, and potential consequences for 'unlawful' use of District water. SSJID updated its policy for unlawful use of district water and released an 'Urgent Drought Bulletin' on May 8, 2015 containing amended rules and regulations. The updated policy gives the District authority to remove facilities used by a grower if the grower is in violation of the policy two times after their allocation expires.

¹⁶ Customers who have filed a service abandonment agreement with the District in the past are considered Tier 2 customers if they petition the Board to amend the abandonment agreement and reinstate District service. Under the contingency plan the District has no obligation to provide water to Tier 2 customers during times of shortage. Newly annexed land is also subject to Tier 2 restrictions.

SUPPLY MANAGEMENT

During past droughts, SSJID has implemented several extraordinary operational measures to manage limited water supplies, and has also augmented the water supply available to growers. These specific efforts are described below. In future droughts, SSJID will consider enacting similar management actions.

Extraordinary Operational Measures

Having historically achieved precise control of system inflows, SSJID has concentrated recent efforts on increasing operational efficiency of the lateral distribution system. Most notable is the Irrigation Enhancement Project (also known as the Division 9 Surface Water Supply Project) initiated in 2008 and completed in time for the 2012 irrigation season. The project involved the design and construction of the first pressurized pipeline network as part of the District's distribution system and incorporates state-of-the-art technologies and water management features. The project provides pressurized surface water to a portion of the District west of Ripon (formerly in Division 9, now in Division 6) that has a high concentration of permanent crops and pressurized irrigation systems that, in the past, predominately used groundwater. The project alleviated concerns of saline groundwater being used for irrigation and increased direct and in-lieu groundwater recharge, thus helping to prevent overdraft of the underlying aquifer. The system includes a regulating reservoir, termed the East Basin; a pumping plant with seven pumps; 19 miles of pipeline that serves a current total of 77 customers (as of 2020) and about 3,800 acres; automatic flow control valves and magnetic flow meters at each turnout; soil moisture sensors in growers' fields; and online water ordering. The District has since drilled two supplemental wells as an additional supply for the East Basin. Each well is screened at different depths to withdraw water from two different aquifer layers. At the pump station, variable frequency drive (VFD) pump controllers allow precise flow rates to be provided without wasting energy. The pumps pressurize water from the East Basin, providing 50 to 60 pounds per square inch (psi) at the turnouts, eliminating the need for booster pumps to operate pressurized irrigation systems.

Beyond the Irrigation Enhancement Project, the District offers programs to its customers that allow them the flexibility to transfer District-provided water and well water within the District's boundaries, requiring extensive coordination between office staff, district operators, and growers.

In addition to the magnetic flow meters installed at delivery points in the Irrigation Enhancement Project area, SSJID has more than 310 magnetic meters installed at delivery locations throughout the District. In recent years, SSJID has installed supervisory control and data acquisition (SCADA) systems on all meters to monitor deliveries more closely. In addition, division managers carry portable flow meters to verify on-farm deliveries. Increased flow measurement will allow the District to better match inflows into the system with on-farm deliveries, minimizing system spills and improving volumetric billing.

In addition, the District operated Woodward Reservoir at lower surface elevations in 2015 to reduce seepage and evaporation.

Supply Augmentation

In 2015, the District developed several programs to augment growers' 36 inch water allotment. SSJID established a 'Master Account' for allotments that informs each grower, based on acreage farmed and the 36 inch water allotment, how much district water (in acre-feet) they can use to irrigate their crops, and then growers decide when and where to apply the water. Through this Master Account, growers can apply more than the 36 inch allotment to a single field, but must account for the extra water by applying less than the 36 inch allotment on another field such that the overall allotment on the combined fields does not exceed 36 inches per acre. As described in the previous section, in 2015 growers also had the ability to transfer water to another farmer through a transfer agreement. In addition, growers were allowed to transfer water from a private well to any location in the district. The recipient of the water transfer is charged a \$3 per acre-foot conveyance fee.

The District is open to receiving recycled wastewater for irrigation purposes if it is technically feasible and locally cost effective for all stakeholders.

MONITORING AND EVALUATION OF THE DROUGHT MANAGEMENT PLAN (§10826.2(B)(3))

Continuous monitoring of hydrologic conditions, water supply, water deliveries, operational efficiency, and other metrics is an important part of SSJID's water management in any year, but especially in times of drought. SSJID continually monitors changes in water supply availability and drought severity, allowing the District to adapt and align its water management efforts per the Drought Management Plan to best distribute and manage available water resources for the benefit of lands within the District's service area boundaries. SSJID's extensive SCADA network, array of reservoir and flow monitoring sites, and water supply forecasting are just a few of the many resources SSJID uses to proactively monitor drought resilience and response efforts.

Review of these metrics following a period of drought allows SSJID to evaluate the cumulative impacts of drought and the overall effectiveness of the DMP over consecutive dry years. Analyses of past drought periods also provide opportunities to revise the DMP and improve drought management within the District moving forward. To this end, the "Evaluation of the 2012-2016 Drought" section, below, includes a review of the most recent drought, its effects in SSJID, and the overall effectiveness of the DMP during the 2012-2016 drought.

COMMUNICATION PROTOCOLS AND PROCEDURES (§10826.2(B)(4))

Internal Communication and Outreach

SSJID regularly provides educational resources and conducts outreach activities to support efficient water management by its irrigation customers. During drought, SSJID increases these efforts to further encourage on-farm water conservation and to keep growers informed of changes to the District's policies and practices to manage limited water supplies.

Past customer service and outreach activities have included drought workshops, more frequent grower meetings, and expanded public outreach through the District website and other reference materials.

In 2015, SSJID published six 'Emergency Drought Bulletins' to inform growers and the general public about actions the District was enacting to combat the drought. These bulletins are included as attachments to this DMP.

SSJID Emergency Drought Bulletins (Attachment D-2.)

- Emergency Drought Bulletin 1 – March 15, 2015
- Emergency Drought Bulletin 2 – April 6, 2015
- Emergency Drought Bulletin 3 – April 27, 2015
- Emergency Drought Bulletin 4 – May 8, 2015
- Emergency Drought Bulletin 5 – June 8, 2015
- Emergency Drought Bulletin 6 – July 8, 2015

In 2015, SSJID also created a Drought Task Force, with two dedicated staff members responsible for assisting growers to stay within the 36-inch allocation that year. consisting of two employees from both the engineering and water operations department. The Drought Task Force worked with more than 550 customers and evaluated water usage on 756 parcels that used more than 36 inches of irrigation water in 2014 in order to evaluate the accuracy of the District's water use measurement methods.

The Task Force also answered 'Consumption Review' requests from growers, offering helpful suggestions and recommending ways to adjust irrigation practices in order to get through the difficult 2015 season. The Task Force also informed growers of the District's transfer and 'Master Account' programs, as well the online account services. When necessary, the Task Force would visit fields while the growers were irrigating to measure flows and verify accuracy. Since 2013, growers are able to view their water use and water bill through an online application, which tracks daily water consumption. In 2015, if a grower wanted a more formal review of their water consumption, they had the option of applying for a water consumption review by the Drought Task Force. The review consisted of five steps:

1. Task Force member prepared a 2014 water consumption report based on 2014 delivery records.
2. Task Force sent the consumption report and allotment notification to the grower.
3. Task Force set a time to review consumption report and, if applicable, request information on irrigation system.
4. Task Force inspected the grower's parcel(s) and consumption checklist.
5. Task Force reviewed and updated SSJID delivery records, as needed.
6. When necessary, the Task Force corrected data entry errors, credited parcels where data errors were found, evaluated sprinkler system flow rates, and measured pipeline flows.

External Communication and Outreach

Outside of the District, SSJID coordinates and collaborates extensively with others to coordinate operations in all years. The District meets monthly with the USBR, U.S. Fish and Wildlife, California Water Resources Control Board, California Wildlife Conservation Board, and others to coordinate efforts. SSJID has also partnered with the Cities of Ripon and Escalon to form the South San Joaquin Groundwater Sustainability Agency (SSJGSA), which is responsible for groundwater management in its area of the Eastern San Joaquin Groundwater Subbasin.

Additional examples of collaboration and coordination activities include the following:

- Coordination with the State office of Emergency Services to respond to local drought emergencies.
- Reporting of information to the California Energy Commission, the California Department of Water Resources, and other governmental entities as necessary
- Coordination with OID and Reclamation with regard to Stanislaus River water supplies and demands
- Cooperation with OID as part of the Tri-Dam Project to operate and maintain the Donnells, Beardseley, and Tulloch reservoirs

The District also meets with local cities regarding groundwater resources, water conservation and recycling, and public education and outreach. The District General Manager makes numerous presentations to various local groups in the area discussing the drought and SSJID's responses and water management.

POTENTIAL FINANCIAL IMPACTS OF DROUGHT AND PROPOSED DISTRICT MANAGEMENT MEASURES (§10826.2(B)(5))

SSJID jointly operates the Tri-Dam Project with Oakdale Irrigation District. Facilities include Beardsley, Donnells, and Tulloch reservoirs and dams, which provide both districts with storage and electrical generation. During droughts there is less water to release from the reservoirs,

limiting power generation considerably. Power generation is the biggest loss in revenue for the District.

During past droughts, SSJID also increased expenditures as staff time was diverted toward public outreach activities and customer support. Past customer service and outreach activities during drought are described above in DMP section “Communication Protocols and Procedures.” To mitigate the decrease in revenues from water sales and increase in staff time expenditures during drought, the District reduces capital funds spent on district maintenance and places more emphasis on water conservation programs. The District’s rate structure also bases a majority of water charges on a fixed (per-acre) component, which helps maintain revenue stability across years despite variability in water sales. In addition to reduced water charges to irrigation customers, revenues decrease as a result of decreased water sales through out of district agreements and other transfers and decreased revenues from power generation from the Tri-Dam Project.

To ensure that delinquent water charges remain an infrequent occurrence, SSJID enforces a denial of water service policy under the following circumstances:

1. The District denies water service to any land having outstanding flat rate charges as collected on the San Joaquin County tax rolls.
2. The District denies water service to any land having outstanding volumetric charges in excess of \$10 for 45 days. At the conclusion of each irrigation season, all charges must be paid in full — even if the balance is less than \$10 — in order to receive water the following irrigation season.

EVALUATION OF THE 2012-2016 DROUGHT

The following sections describe the impacts of the 2012-2016 drought on water supply and water demand in SSJID. Water supply and demand in 2011 are also provided for comparison with a normal, full-supply year preceding the drought period.

This discussion also examines the effectiveness of SSJID’s past drought resilience and drought response efforts, identifies lessons learned from the drought, and provides context for planning future actions.

DROUGHT IMPACTS ON WATER SUPPLY

SSJID’s water supplies in 2011-2016 are discussed to illustrate the effect of actions taken by SSJID and its customers to manage available water supplies during drought. The years 2012-2016 represent a historic, multi-year drought, while 2011 represents a normal year with full allocation prior to the drought. All sources of supply identified in the AWMP water budget are

summarized below, including surface water inflows (deliveries from Joint Supply Canal, ordered spillage), groundwater inflows (District and private groundwater pumping, pumping for groundwater transfer to Mountain House), and other inflows (OID spills to Main Canal, stormwater runoff, tributary inflow). Releases from Woodward Reservoir are also discussed, as they pertain to SSJID’s water supply operations.

SSJID diverts water stored in New Melones Reservoir to Woodward Reservoir through the Joint Supply Canal. The District manages Woodward Reservoir to best meet downstream demand. From 2012 to 2016 the District diverted an average of 211,000 af per year, compared to 219,000 af in 2011 (Figure D-2). During the first two years of drought in 2012-2013, diversions were higher than those in 2011. In 2015, the District managed Woodward Reservoir at lower water surface elevation to reduce reservoir seepage and evaporation by reducing diversions into the Joint Supply Canal.

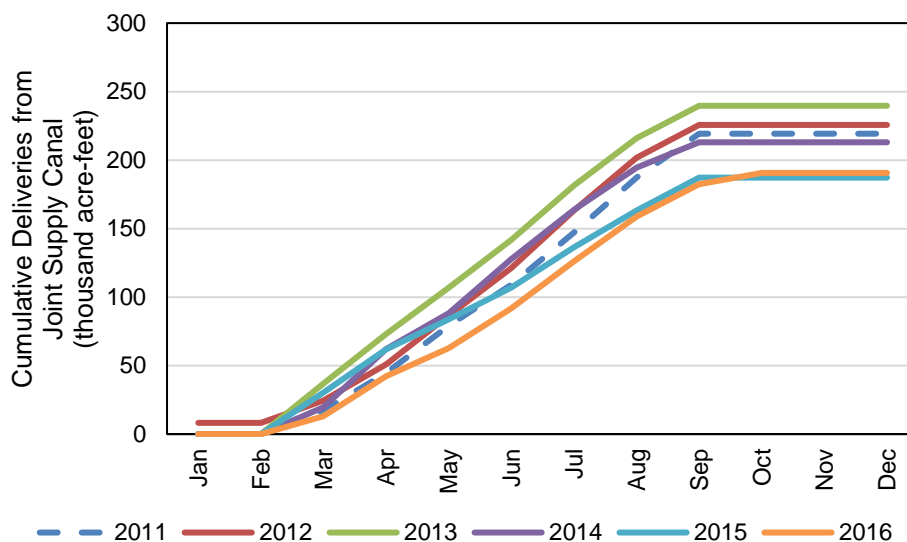

Figure D-2. Monthly Cumulative Deliveries from Joint Supply Canal, 2011-2016.

A majority of District surface water is delivered downstream of Woodward Reservoir. As shown in Figure D-3, Woodward Reservoir releases were greatest in 2012 and 2013, averaging over 189,000 af per year. Releases in 2014 dropped substantially to 167,000 af. Woodward Releases in 2015 and 2016 were still lower, totaling 144,000 and 152,000 af per year, respectively.

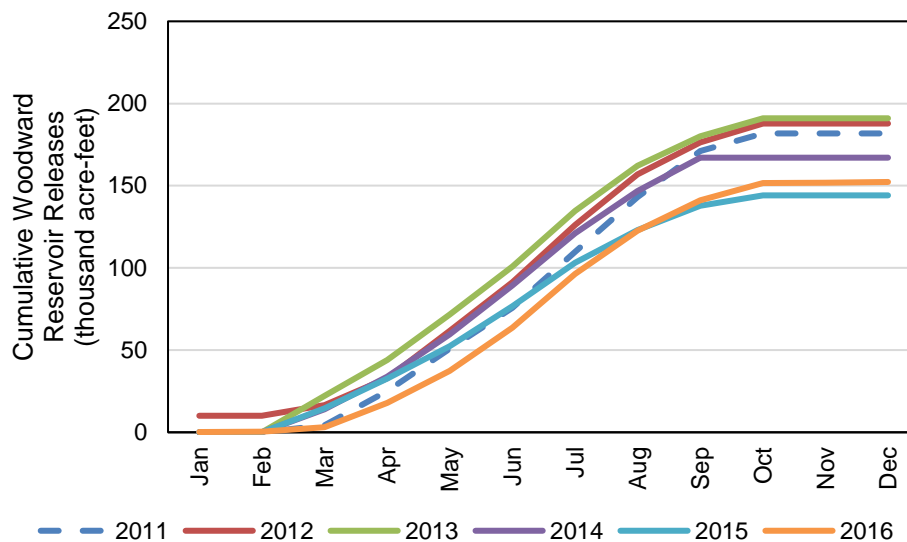

Figure D-3. Monthly Cumulative Woodward Reservoir Releases, 2011- 2016.

Currently, the District does not rely heavily on groundwater to supplement surface water supply. From 2012-2016, District pumping accounted for approximately 2-3 percent of the SSJID supply used to support on-farm deliveries (Figure D-4).

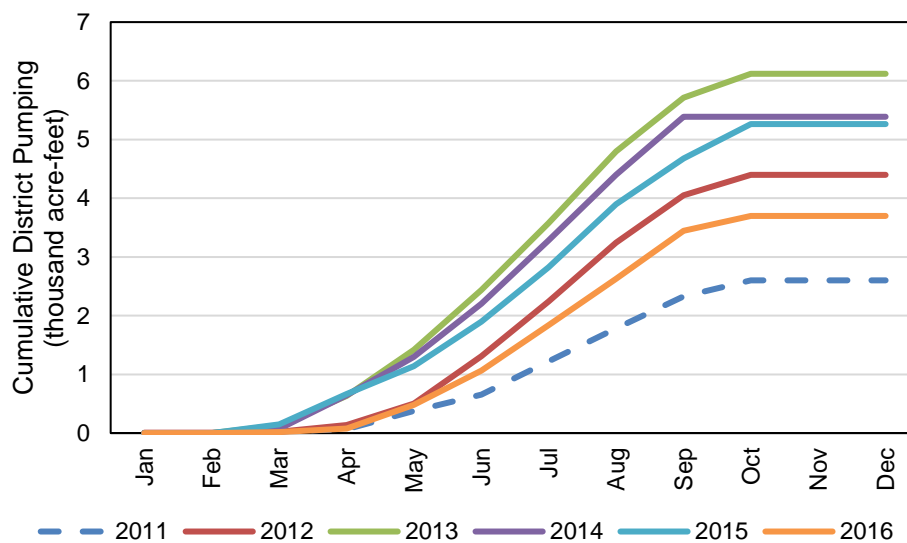

Figure D-4. Monthly Cumulative District Pumping, 2011-2016.

Between 2012 and 2016 private pumping averaged approximately 70,000 af per year (Figure D-5). Total annual private pumping did not change considerably between 2012 and 2014, but increased by approximately 10,000 to 20,000 af in 2015 and 2016.

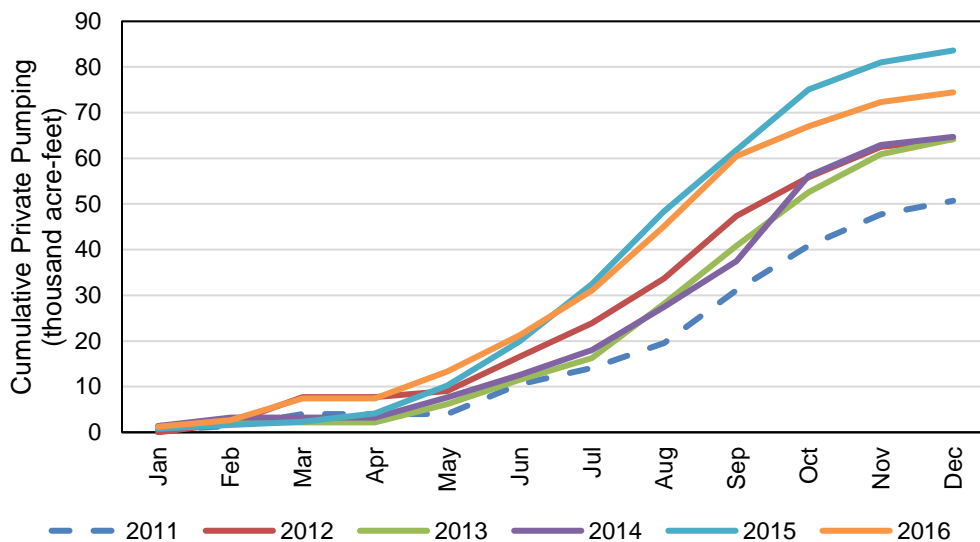

Figure D-5. Monthly Cumulative Private Pumping, 2011-2016.

Other water supply available to SSJID includes spills from Oakdale Irrigation District (OID) into the Main Supply Canal, as well as other stormwater runoff and tributary inflow to the SSJID system. These cumulative volumes are shown in Figure D-6. On average, spillage from OID averaged nearly 3,000 af per year from 2012-2016. Other inflows averaged nearly 5,000 af per year over the same period, for a total average of approximately 8,000 af per year.

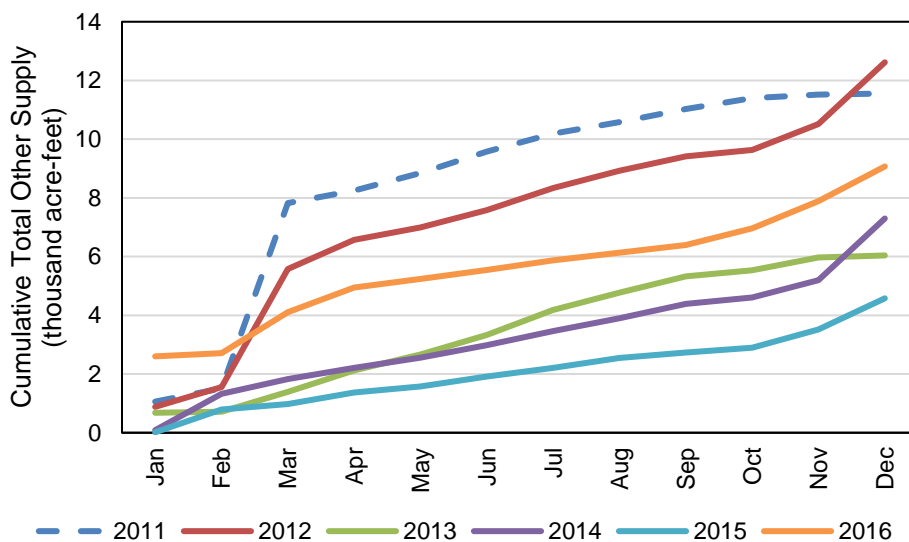

Figure D-6. Monthly Cumulative Total Other Supply, 2011-2016.

Between 2012-2016, SSJID’s total water supply (surface water, groundwater, and other water) averaged approximately 295,000 af per year, compared to 293,000 af in 2011 (Figure D-7).

SSJID’s total water supply was greatest during 2013, at approximately 316,000 af. The comparatively small changes in total supply (surface water, groundwater, and other supply), even at the height of drought, demonstrate the resiliency of the District’s water supplies and the benefits of SSJID’s conjunctive management. While surface water supplies dropped as the drought continued, the District and its customers were effectively able to make up the difference through increased pumping of groundwater. Their ability to do so was directly supported by groundwater recharge of surface water supplies in the years preceding the drought.

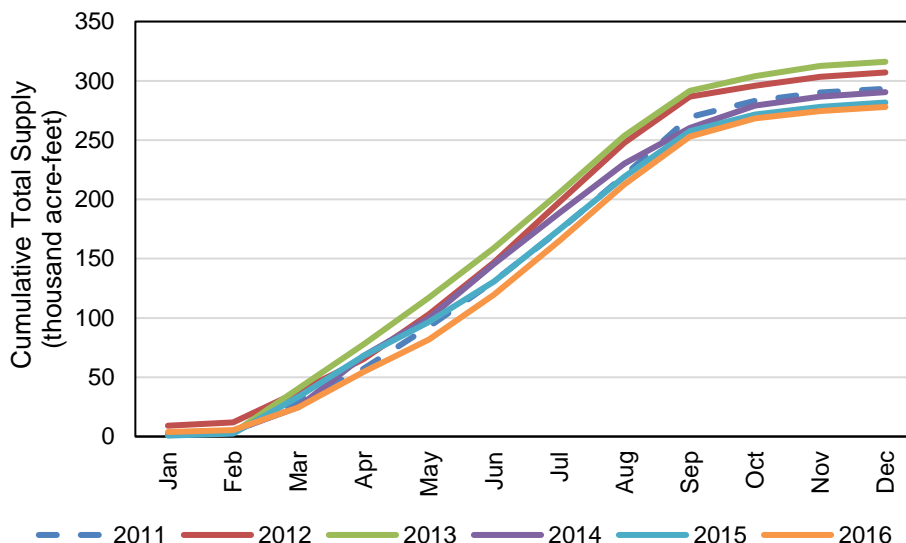

Figure D-7. Monthly Cumulative Total Supply, 2011-2016.

DROUGHT IMPACTS ON WATER DEMAND

Water demand in the SSJID service area from 2011-2016 is discussed to illustrate the effect of actions taken by SSJID and its customers to manage water use during drought. The years 2012-2016 represent a historic, multi-year drought, while the year 2011 represents a normal year with full surface water allotment. Overall demand is characterized and discussed based on several parameters:

- monthly farm deliveries (as quantified through the SSJID water balance), a measure of farm surface water demand
- reference evapotranspiration (ET_o), a measure of atmospheric water demand
- crop evapotranspiration of applied water (ET_{aw}), a measure of agricultural consumptive water demand.

Figure D-8 summarizes SSJID delivery volumes from 2011 through 2016, which were calculated as the closure of the District Laterals water budget. The District’s total deliveries ranged from approximately 105,000 af to 146,000 af per year across the entire period. Compared to 2011, deliveries were generally higher during the first three years of drought (2012-2014), but lower during the final years (2015-2016). Lower deliveries in 2015 are attributed largely to the District’s 36 inch restrictions on water supply available to irrigators.

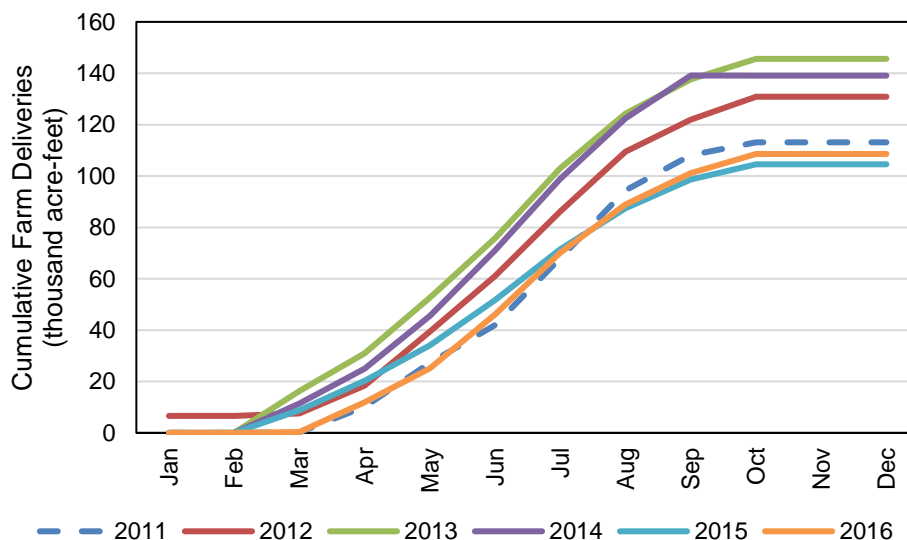

Figure D-8. Monthly Cumulative SSJID Farm Deliveries, 2011-2016.

Daily cumulative atmospheric water demand, ET_o , for 2011-2016 is shown in Figure D-9. Total ET_o , as measured at the Manteca CIMIS station, ranged between 49.7 inches and 56.9 inches per year between 2011-2016. Total ET_o during the drought was about seven to 14 percent higher than in 2011.

Agricultural consumptive applied water demand, ET_{aw} , follows a trend similar to that of ET_o . As ET_o increases in the late spring and summer months with warmer temperatures and increased net radiation, so does ET_{aw} (Figure D-10). The total volume of ET_{aw} in the SSJID service area was lowest during 2011, the last year of full allotment preceding the drought. ET_{aw} increased to between about 130,000 af and 145,000 af in during the 2012-2016 drought, driven by increased ET_o and shifts in agriculture toward higher-demand permanent crops such as orchards.

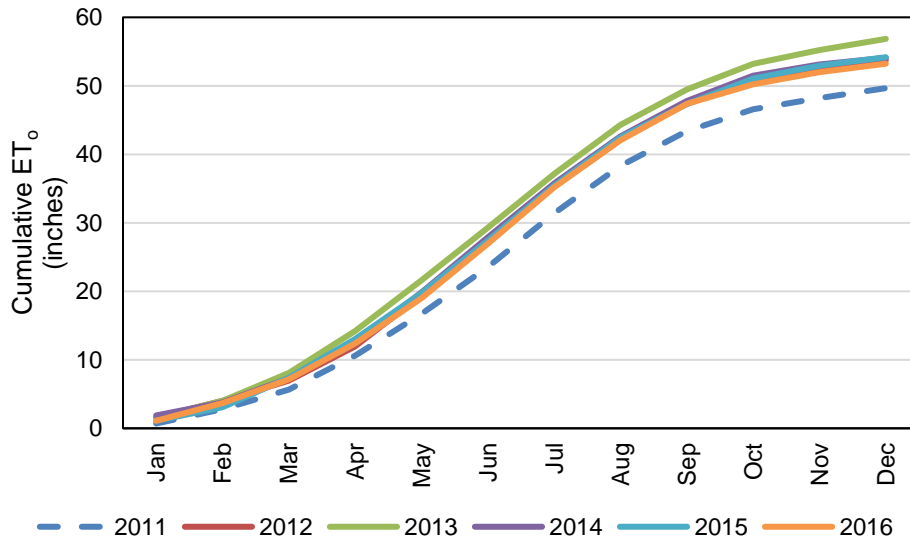

Figure D-9. Daily Cumulative ET₀, 2011-2016.

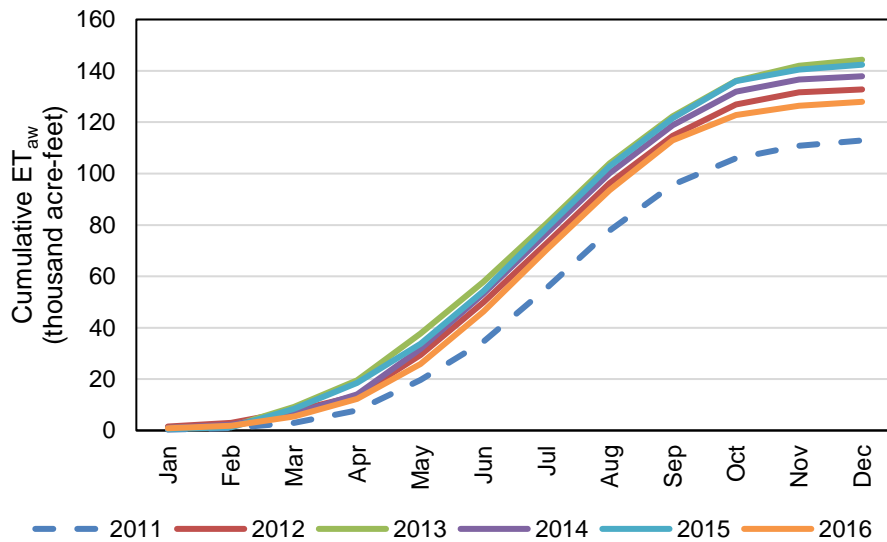

Figure D-10. Monthly Cumulative Crop ET_{aw}, 2011-2016.

EFFECTIVENESS OF SSJID DROUGHT PLANNING EFFORTS IN 2012-2016

The evaluation of drought impacts on SSJID's water supply and water demand generally indicates that SSJID's ongoing drought planning efforts are effective in supporting its growers' ability to weather the potential impacts of even prolonged droughts when District surface water supplies are limited.

In 2012-2013, the total deliveries from the Joint Supply Canal (Figure D-2) and the total Woodward Reservoir releases into the SSJID system (Figure D-3) were higher than in 2011, as SSJID supplied its growers with more farm deliveries early in the drought (Figure D-8).

As the drought continued into 2015-2016, the District managed Woodward Reservoir at lower water surface elevations to reduce reservoir seepage and evaporation. This was largely accomplished by reducing diversions into the Joint Supply Canal. Also, in 2015, the District restricted the water supply available to growers for purchase to just 36 inches. This contributed to the decrease in farm deliveries and Woodward Reservoir releases that year.

Even while these restrictions were in place, growers in the District were able to supplement their water supply with private pumping. Compared to 2012-2014, the total private pumping volume increased by approximately 20,000 af in 2015. In 2016, as farm deliveries increased toward the volume delivered in 2011, the total private pumping again declined. These shifts suggest that although the severe drought and restricted water supplies in 2015 pushed growers to pump more groundwater for irrigation, the availability and affordability of SSJID's supplies strongly incentivize conjunctive management and increased use of surface water when it is available.

As described above, the comparatively small changes in total supply across the 2011-2016 time period, even at the height of drought, demonstrate the resiliency of the District's water supplies and the benefits of SSJID's conjunctive management. When surface water supplies dropped in 2015, growers were able to utilize groundwater supplies buffered by years of conjunctive management and recharge in SSJID.

Cropping and ET_{aw} volumes in SSJID also suggest that the District's drought planning efforts are effective in sustaining crop production even in the midst of drought. SSJID supplies water to large areas of permanent and specialty crops that require a steady annual water supply. Throughout the drought, the volume of total agricultural ET_{aw} in SSJID was largely sustained between 130,000 af and 145,000 af per year. This is likely attributable in part to increases in on-farm water use efficiency, enhanced grower outreach and education, and increased distribution system efficiency.

These findings indicate that SSJID's drought planning efforts are effective in supporting growers in sustained agricultural production even during extended droughts, when District supplies are limited.

Intentionally Left Blank

**ATTACHMENT D-1. AN EXAMPLE TRI-DAM REPORT AND PROJECTED WATER
BUDGET**

Ending At Midnight - September 21, 2015

CURRENT RESERVOIR CONDITIONS

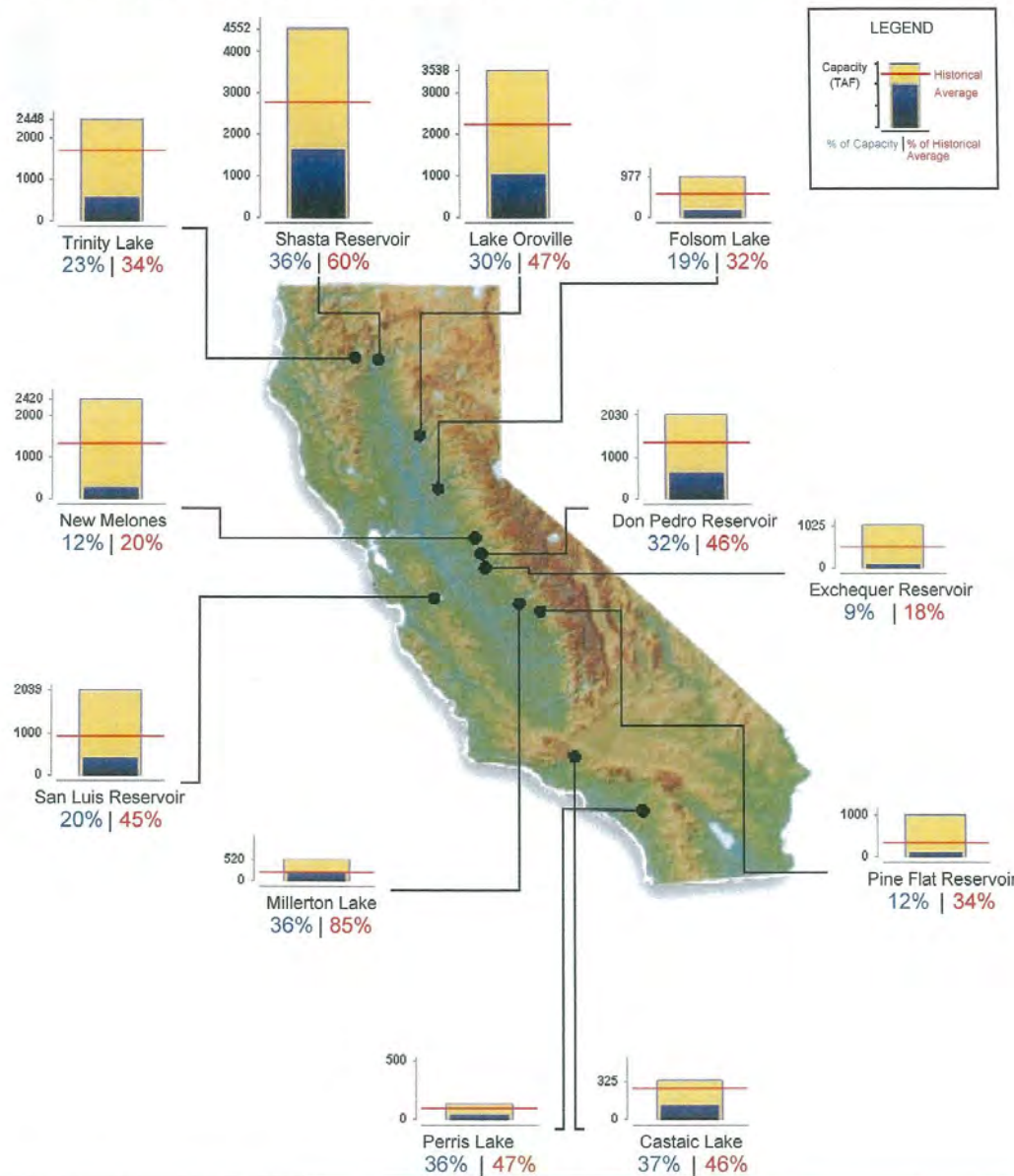

Graph Updated 09/22/2015 07:15 AM

TRI-DAM OPERATION'S DAILY REPORT OF MIDNIGHT WATER DATA					
21-Sep-15					
	DONNELLS	BEARDSLEY	SAND BAR	MELONES	TULLOCH
MAX ELEV	4916.00	3397.00		1088.00	510.00
MAX STORAGE	64,325	97,802		2,419,523	66,968
SPILL CREST	4898.00	3368.00	2755.00	1088.00	481.00
STORAGE	56,893	77,838		2,419,523	37,623
ELEVATION	4,837.79	3,336.17	2,753.83	801.18	502.12
STORAGE	34,414	58,023		276,593	57,624
STORAGE CHANGE	(249)	(248)		0	67
ACRE FEET USED	274	589	497	2,001	1,716
AVERAGE DRAFT	138	297	251	1,009	865
AVERAGE SPILL	0	0			0
AVERAGE BYPASS	25	0	0		0
AVERAGE INFLOW	38	172		1,058	899
MIDNIGHT DRAFT	60	300	233		828
MIDNIGHT SPILL	0	0			0
MIDNIGHT BYPASS	25	0	0		0
PEAK INFLOW	278	510			1,631
GENERATION					
HOURS RUN	18:14	24:00	24:00		24:00
KWH	338,343	89,435	132,234		215,434
MONTHLY TOTAL	8,140,141	1,931,930	2,825,757		5,456,782
GOODWIN			A-BAY		
ELEVATION	359.81		ELEVATION		3134.91
STORAGE	523		STORAGE		352
SURCHARGE	21		AVERAGE DRAFT		55
JT MAIN AVERAGE	565		AVERAGE SPILL		0
SO MAIN AVERAGE	166		S-88 AVERAGE		23
SSJID MAIN AVERAGE	419		S-89 AVERAGE		56
OID NORTH AVERAGE	144		S-98 AVERAGE		154
GAYLORD AVERAGE	0		BLACK CREEK		0
FRYMIRE AVERAGE	9				
SEWD AVERAGE	0				
WEATHER					
WEATHER	HI TEMP	LO TEMP	PRECIP	MONTH	ANNUAL
STRAWBERRY	87	50	0.00	0.12	1.35
DONNELLS	88	48	0.00	0.19	0.87
BEARDSLEY	88	52	0.00	0.11	0.50
SAND BAR	92	52	0.00	0.15	0.26
TULLOCH	100	64	0.00	0.02	0.02
CHECKED BY:SEEL			SPICER	49565	
			RELIEF	9462.3	

SOUTH SAN JOAQUIN
 IRRIGATION DISTRICT
 7 Day Water Usage

SSJID 7 DAY WATER USAGE REPORT FOR THE WEEK OF
 Sunday, September 06, 2015

DATES	6-Sep-2015	7-Sep-2015	8-Sep-2015	9-Sep-2015	10-Sep-2015	11-Sep-2015	12-Sep-2015
MDC Maximum Flow Per Division (cfs)							
MDC-Control	239.48	236.88	264.89	265.59	300.51	290.49	280.63
Division 1	47.86	103.25	84.10	55.00	35.66	39.14	69.89
Division 2	62.43	55.84	42.26	66.24	88.57	68.31	80.75
Division 3	44.73	61.30	61.73	42.70	58.97	59.02	57.02
Division 4	40.37	39.26	10.94	31.90	39.25	39.40	37.68
Division 5	42.82	56.04	28.40	104.50	88.90	90.47	86.71
Division 6	50.80	46.44	53.94	46.18	28.36	20.09	13.16
SP-7	0.00	0.00	0.00	0.00	0.00	0.00	0.00
MDC Minimum Flow Per Division (cfs)							
MDC-Control	190.12	188.42	193.84	255.78	231.38	249.69	200.19
Division 1	27.01	26.36	34.25	10.30	10.27	19.65	24.46
Division 2	39.94	12.16	14.29	22.36	35.44	20.74	18.63
Division 3	27.99	35.85	36.48	36.49	38.58	52.76	36.72
Division 4	35.73	8.79	6.24	7.80	29.73	34.73	11.26
Division 5	25.75	16.44	11.71	25.97	75.37	75.78	51.35
Division 6	12.55	0.00	15.34	0.00	0.00	0.00	0.00
SP-7	0.00	0.00	0.00	0.00	0.00	0.00	0.00
MDC Flow Total Per Division (AcFt)							
MDC-Control	461.72	419.25	448.44	517.62	532.43	518.89	462.07
Division 1	62.79	121.63	134.82	40.68	47.96	64.31	66.06
Division 2	102.67	37.75	53.11	88.90	125.45	81.10	70.56
Division 3	69.39	101.62	79.64	72.87	95.36	107.58	81.85
Division 4	74.71	27.38	16.73	54.98	70.60	73.31	31.01
Division 5	75.23	76.49	46.08	161.69	162.51	161.37	138.04
Division 6	74.00	44.79	54.94	41.52	13.00	18.54	11.11
SP-7	0.00	0.00	0.00	0.00	0.00	0.00	0.00
Drains (OID)	26.81	20.16	-	-	2.28	7.16	-
Woodward Levels	206.82	206.87	206.91	206.96	206.95	207.01	207.17
7 DAY FLOW TOTAL (AcFt)						SEASON TO DATE (AcFt)	
MDC-Control	3360.43	98.35% Operators		116559.20		96.24%	
Drains (OID)	56.42	1.65%		4548.34		3.76%	
	3416.85	100.00% TOTAL WATER USED		121107.54		100.00%	
Division 1	538.24	15.75% J. Hasten & A. Podesto		14786.79		12.21%	
Division 2	559.56	16.38% B. Anderson & Andrew		18656.15		15.40%	
Division 3	608.31	17.80% K. Obrochta & R. Sprinkle		19490.70		16.09%	
Division 4	348.71	10.21% C. Hodge & R. Shipman		12776.88		10.55%	
Division 5	821.41	24.04% J. Lourenco & T. Hagins		21128.43		17.45%	
Division 6	257.89	7.55% J. Wirstlin & M. Donahue		17348.07		14.32%	
SP-7	0.00	0.00% -		0.00		0.00%	
	282.73	8.27% Water used to run the canal		16920.52		13.97%	

Note: Water used to run canal includes Main Canal operation, evaporation, percolation, and some direct diversions from the Main Canal

Printed On
 9/14/2015
 8:39 AM

SOUTH SAN JOAQUIN
 IRRIGATION DISTRICT
 7 Day Water Usage

SSJID 7 DAY WATER USAGE REPORT FOR THE WEEK OF
 Sunday, September 13, 2015

DATES	13-Sep-2015	14-Sep-2015	15-Sep-2015	16-Sep-2015	17-Sep-2015	18-Sep-2015	19-Sep-2015
MDC Maximum Flow Per Division (cfs)							
MDC-Control	268.43	269.85	272.35	272.35	218.05	215.86	252.03
Division 1	84.87	81.01	67.40	66.23	87.41	73.55	80.96
Division 2	68.23	59.68	46.11	41.02	36.73	35.71	55.52
Division 3	43.91	45.94	44.66	42.20	12.96	30.92	32.99
Division 4	13.84	37.89	32.27	10.74	35.06	33.30	12.79
Division 5	59.43	59.61	74.58	103.19	83.34	52.52	66.06
Division 6	5.74	28.01	29.79	39.63	44.90	36.06	13.04
SP-7	0.00	0.00	0.00	0.00	0.00	0.00	0.00
MDC Minimum Flow Per Division (cfs)							
MDC-Control	162.80	164.95	190.12	179.43	168.72	168.18	175.83
Division 1	24.52	26.64	48.09	29.34	29.26	38.49	23.22
Division 2	16.92	11.09	5.65	10.88	16.87	18.82	19.96
Division 3	15.88	15.67	20.83	7.81	4.10	4.00	28.58
Division 4	9.39	9.34	9.04	7.79	9.77	9.73	9.93
Division 5	50.68	45.01	45.14	69.71	38.96	11.99	40.19
Division 6	0.00	0.00	21.06	3.06	2.42	0.60	0.00
SP-7	0.00	0.00	0.00	0.00	0.00	0.00	0.00
MDC Flow Total Per Division (AcFt)							
MDC-Control	433.06	441.26	499.78	442.70	377.97	378.34	431.14
Division 1	109.17	81.69	117.87	88.57	109.95	112.96	105.09
Division 2	54.78	63.68	51.24	42.85	49.51	50.45	70.82
Division 3	55.36	40.55	95.22	52.04	9.99	21.90	61.04
Division 4	23.86	50.68	41.16	18.87	59.17	43.98	22.99
Division 5	110.45	103.78	132.43	165.17	109.94	81.88	106.20
Division 6	0.44	29.75	49.61	36.33	48.86	30.25	11.40
SP-7	0.00	0.00	0.00	0.00	0.00	0.00	0.00
Drains (OID)	-	-	7.57	-	29.28	-	-
Woodward Levels	207.35	207.55	207.77	208.08	208.41	208.73	209.02
7 DAY FLOW TOTAL (AcFt)						SEASON TO DATE (AcFt)	
MDC-Control	3004.26	98.79% Operators		119563.46		96.31%	
Drains (OID)	36.85	1.21%		4585.19		3.69%	
	3041.11	100.00% TOTAL WATER USED		124148.65		100.00%	
Division 1	725.29	23.85% J. Hasten & A. Podesta		15512.08		12.49%	
Division 2	383.33	12.60% B. Anderson & G. Wallace		19039.48		15.34%	
Division 3	336.11	11.05% K. Obrochta & R. Sprinkle		19826.81		15.97%	
Division 4	260.70	8.57% R. Shipman & C. Hodge		13037.58		10.50%	
Division 5	809.86	26.63% J. Lourenco & T. Hagins		21938.29		17.67%	
Division 6	206.64	6.79% J. Wirstin & D. Pauly		17554.71		14.14%	
SP-7	0.00	0.00% -		0.00		0.00%	
	319.18	10.50% Water used to run the canal		17239.70		13.89%	

Note: Water used to run canal includes Main Canal operation, evaporation, percolation, and some direct diversions from the Main Canal.

Printed On
 9/21/2015
 9:48 AM

	B	C	D	E	F	G	H
3	Projected Water Budget for 2015						
4	Updated September 21, 2015						
5							
6							
7							
8		Current	9/21/2014		2014 Full Water Year	2013 Full Water Year	
9	SSJID Goodwin diversions	184,800	210,659		215,884	241,374	
10	OID drain water year-to-date per F. Avila	4,585					
11	OID drain water as % of diversions to-date	2.5%					
12	MDC losses to-date per F. Avila	17,240					
13	MDC losses as % of diversions to-date	9.3%					
14	Elevation of Woodward	209.00					Excludes 40,000 a-ft to SLDMWA
15	Accumulated inflow	327,000	338,000		346,000		
16							
17	Water Budget for Different Amounts of Inflow						
18							
19	Description of inflow assumptions →	No Inflow	DWR 90% Probability May 8 Forecast	Actual YTD Inflow	SSJID Sept 21 Forecast	SSJID July 6 Forecast	Cons. Acct Threshold
20							
21	New Melones assumed inflow volume →	0	263,000	327,000	335,000	310,000	375,000
22							
23	SSJID's 1988 contract water (100,000 + X/3)	100,000	188,000	209,000	212,000	203,000	225,000
24	Maximum withdrawal from conservation account	78,397	37,000	16,000	13,000	22,000	-
25	Available to divert from Stanislaus River	178,397	225,000	225,000	225,000	225,000	225,000
26							
27	Evaporation and seepage losses (ISC, MSC, Woodward)	(37,000)	(37,000)	(37,000)	(37,000)	(37,000)	(37,000)
31	Water treatment plant normal use	(19,210)	(19,210)	(19,210)	(19,210)	(19,210)	(19,210)
32	Water treatment plant 20% reduction for 7 months	2,241	2,241	2,241	2,241	2,241	2,241
33	Total adjustments between Goodwin and Woodward	(53,969)	(53,969)	(53,969)	(53,969)	(53,969)	(53,969)
34	Available to release from Woodward into MDC	124,428	171,031	171,031	171,031	171,031	171,031
35							
36	Normal well water supply (Estimated by F. Avila)	6,000	6,000	6,000	6,000	6,000	6,000
39	Expected OID tailwater (using % at top of page)	450	450	450	450	450	450
40	Delivery to Ripon (Max past use: 1,245)	(1,245)	(1,245)	(1,245)	(1,245)	(1,245)	(1,245)
41	Spills to drains (estimated based on report from Frank)	(18,600)	(18,600)	(18,600)	(18,600)	(18,600)	(18,600)
42	Distribution losses (excludes drain water)	(16,642)	(17,520)	(17,520)	(17,520)	(17,520)	(17,520)
43	Total adjustments between Woodward and the farmgate	(30,037)	(30,915)	(30,915)	(30,915)	(30,915)	(30,915)
44	Available for irrigation at the farmgate	94,391	140,116	140,116	140,116	140,116	140,116
45							
51	Conservation account						
52	Beginning balance	78,397	78,397	78,397	78,397	78,397	78,397
53	Withdrawal from conservation account				0		
54	Addition to conservation account				21,603		
55	Ending balance (limited to 100,000 acre-feet)				100,000		
56							
57	Total diversion expected this year						
58	Estimated daily diversions 9/22 - 9/30/2015 based on 9/21 diversion (Woodward has been filled)				334		
59	Days through 9/30/2015				9		
60	Expected diversions 9/22 - 9/30/2015				3,006		
61	Goodwin diversions to-date				184,800		
62	Expected YTD diversions through 9/30/2015				187,806		
63							
64	Addition to conservation account expected this year						
65	1988 contract diversion quantity				212,000		
66	Less: expected diversion quantity				(187,806)		
67	Available to add to the conservation account				24,194		

9/22/2015

ATTACHMENT D-2. SSJID EMERGENCY DROUGHT BULLETINS

- Emergency Drought Bulletin 1 – March 15, 2015
- Emergency Drought Bulletin 2 – April 6, 2015
- Emergency Drought Bulletin 3 – April 27, 2015
- Emergency Drought Bulletin 4 – May 8, 2015
- Emergency Drought Bulletin 5 – June 8, 2015
- Emergency Drought Bulletin 6 – July 8, 2015

Intentionally Left Blank

EMERGENCY DROUGHT BULLETIN 1 – MARCH 15, 2015



SOUTH SAN JOAQUIN IRRIGATION DISTRICT

**EMERGENCY
DROUGHT
BULLETIN**

**SSJID'S 2015
IRRIGATION WATER
SEASON STARTS
MARCH 15**

EMERGENCY DROUGHT BULLETIN

SSJID IN CRITICAL DROUGHT EMERGENCY

As the Stanislaus River watershed enters its fourth year of consecutive drought conditions, the picture for SSJID and our farmers is bleak. While SSJID may have enough water this year, if the pattern of drought conditions continues, there is a very real possibility our water supply will not last through the end of the 2016 irrigation season. This is a serious and harsh reality, and as such, the SSJID Board of Directors declared a water emergency at its most recent meeting. The Board has reviewed the usage of agricultural water in recent years and has found that it will be necessary to adopt a drought conservation program to reduce the quantity of water used for the purpose of conserving our water supply for the 2015 and 2016 irrigation seasons.

CONDITIONS NECESSITATING AN EMERGENCY DROUGHT DECLARATION

New Melones Reservoir is running out of water. This is the source of SSJID's water supply. The troubling pattern of long, warm dry spells between rain events in the upper watershed is continuing with the result of very little runoff into New Melones Reservoir when it does rain, as the ground and vegetation is so dry that it is soaking up all available moisture. Since October 1, precipitation in the upper watershed has been 60% of normal, and has gotten worse: January was the driest January in history, and in February no snow fell below 8,500 feet of elevation. The Department of Water Resources is expected to announce that the most recent snow survey will show that the snowpack will have declined in the last month to 17-19% of normal. Our estimates show that New Melones may decline to "dead pool" in September. The State Water Resources Control Board (SWB) has issued an advisory that Curtailment Orders for Junior Water Rights holders

are possible if significant improvement in hydrology is not seen in March, given the bleak storage levels in all of the reservoirs, including New Melones. There is not enough water in New Melones to meet the Bureau of Reclamation's regulatory needs and the District's hard cap of 225,000 acre-feet this year. Any additional inflow or any conservation we can save from this year's total of 225,000 acre-feet will count toward meeting our 2016 water needs. This is why stringent conservation measures in the District will be so important during 2015. Every drop of water we save this year may be needed in 2016.

SSJID BOARD PROPOSES A 36 INCH ALLOTMENT

In order to meet the needs of both our agricultural and urban customers with a water supply of 225,000 acre-feet, including supplementation of approximately 54,000 acre-feet of water from our conservation account, the District needs to plan for the worst and hope for the best. By implementing modest conservation measures last year, the District was able to meet the demands of our irrigation and domestic customers with 217,000 acre-feet. More strict conservation measures are going to be required this year, therefore the SSJID Board is proposing to adopt a 36" limit on all parcels. By doing so, the savings will potentially be as much as 39,000 acre-feet, which would be a direct contribution to the 2016 supply. The board understands this will be a serious hardship for many. The intention is to avoid an even more serious hardship for everyone that would result from completely running out of water this year or next. The Board also has established a 10-day rotation schedule.

BOARD DECLARES START OF SEASON TO BE MARCH 15

The District expects to begin its irrigation season on March 15. Prior to the start, the Board of Directors will hold a hearing on March 10 at 9 AM at the District's Main Office followed by a decision whether to adopt a strict water allotment of 36". District studies have shown that more than half of our irrigators use less than 36". With this restriction on supply, it is incumbent upon irrigators to determine for themselves how and when to use their allotment. SSJID staff are currently identifying growers whose usage history is above 42" and will be available to work with them to determine how they can reduce their usage in order to preserve their crops and stay within the drought year allotment.

ALLOTMENT TRANSFERS

Along with the 36" limit, allotment transfers will be allowed. The general rule will be that growers can increase or decrease their water supply by transferring all or a part of the 36" allotment between land parcels, with some exceptions. Once the Board adopts the Water Allotment Policy, the District will have an application form that will be required for transfers, and the deadline for applications will be May 10. Parcels in a single transfer agreement will not need to have the same owners. Only parcels located in the District territory are eligible for the water transfer program. Transfer agreements will be for one year only and will be irrevocable. You will soon receive a notice of the hearing to be held on March 10, along with the detailed allotment policy that the Board is proposing to adopt. Transfer rules and procedures will be included. **PLEASE REVIEW THE POLICY CAREFULLY SO THAT YOU KNOW EXACTLY HOW THE POLICY WILL AFFECT YOUR GROWING SEASON.**

WHAT YOU NEED TO KNOW REGARDING YOUR USAGE

As part of the emergency drought 36" allotment policy, water to growers will be cut off once their allotment is used. It will be your responsibility to know how much allotment you have left at any time, although the District will provide resources to assist you with this. The best resource you will have is access to SSJID's online bill payment and consumption history service, which is available by going to the SSJID website: www.ssjid.com. Directions for applying for an online account are provided in this bulletin. Once you have established an online account, your usage will be updated every day on the website; however keep in mind that the information will be three days old. Your season-to-date usage will be shown on your monthly bill, and most likely beginning in April, your bill will reflect not only acre-feet used but also inches applied. The District will also soon be mailing you a report showing how many inches of irrigation water you used in 2014 on each parcel.

You may also use this simple calculation to convert acre-feet of water used to inches:

Acre Feet divided by Acreage multiplied by 12.

For example: 60 acre-feet (amount used) divided by 15 acres (parcel size) times 12 = 48 inches of water.

DISTRICT WILL OFFER IRRIGATOR ASSISTANCE PROGRAM

The board and employees of SSJID understand that the 36" limit will be a real hardship for many farmers. So SSJID is evaluating the water usage on parcels that used more than 42" in 2014 in order to check the accuracy of the District's water use measurement methods and we are also available to recommend ways to irrigate more efficiently if possible. It is important for you to contact SSJID right away if you are concerned about the accuracy of the District's measurement of your usage. The District staff will work hard to assist you during this difficult year. If you have questions or need assistance with adhering to the 36" limit or applying for a transfer, please call the District office at (209) 249-4600.

DISTRICT WILL ISSUE FURTHER BULLETINS TO UPDATE GROWERS ON DROUGHT CONDITIONS

This is the first of a series of Emergency Drought Bulletins that will be issued throughout the irrigation season. Please be sure to look for and read each bulletin, as changes may be made to the water allotment and transfer programs if conditions change.

Please coordinate with your division manager regarding any repairs to your valves, boxes, etc. If you are aware of any damaged vents, please contact Ron Strmiska Jr., field maintenance supervisor, at (209) 993-9769 as soon as possible.

WATER SEASON 2015 JOB ASSIGNMENTS		24 HOUR EMERGENCY NUMBER 209-249-4632	
DIVISION	PHONE NUMBER	DAYS	NIGHTS
1	209-652-9793	Joe Hasten	Anthony Podesto
2	209-652-9784	Bob Anderson	Andrew Mc Donald
3	209-652-9775	Keith Obrochta	Randy Sprinkle
4	209-652-7025	Collin Hodge	Rob Shipman
5	209-652-3427	Joe Lourenco	Tim Hagins
6	209-652-2409	Jason Wirstlin	Michael Donahue

REGISTER ONLINE TO PAY YOUR BILL AND VIEW YOUR CONSUMPTION HISTORY

SSJID offers online bill payment and the ability to view your water consumption history via its website: www.ssjid.com. This service will be particularly useful to growers this year due to the drought year water allotment policy, because it allows you to monitor your water use as recorded by SSJID. To sign up for online services, simply go online to our website, go to **District Services**, then **Billing and Customer Services**. Here you will find the "Pay your bill online" button. Click, and follow the directions to create your account. You will receive an email verifying that we received your request. Your account will then be linked to your log-on password. Once this process is completed, you will receive another email verifying that you're now ready to utilize the online payment system, as well as to view your account online. Registering online does not obligate you to pay your bill online. Our Finance Department can quickly complete this process in one business day after you request this service. Questions? Call Robin Giuntoli at (209) 249-4610.

www.ssjid.com



EMERGENCY DROUGHT BULLETIN 2 – APRIL 6, 2015



EMERGENCY DROUGHT BULLETIN #2

April 6, 2015

Confirmation of Drought Conservation Program Provisions

The water supply picture looks increasingly grim for the coming growing season. California's governor declared a State of Emergency throughout the state due to severe drought conditions on April 1, 2015. With very little precipitation this past winter, farmers will be relying more on pumping groundwater, having to severely conserve whatever surface water they may have available to them, potentially fallowing crops, and when possible and/or necessary, transferring water allocations between their own parcels, or to other growers' farm operations.

After a public hearing at the South San Joaquin Irrigation District's Board meeting on March 10, the Board voted to adopt the drought conservation program that was described in the first Emergency Drought Bulletin SSJID mailed to you recently. The only change to the original proposal was an extension of the deadline to apply for allotment transfers from May 10 to June 15, 2015. A limit of 36" of irrigation water per parcel will be in effect because the ongoing drought threatens the District's water supply in

2015, and will most likely worsen in 2016. A 10-day rotation schedule was also confirmed.

SSJID's drought task force has already met with many of our growers to review their past year's water consumption history. All of our growers should have received their "consumption history review" in the mail. If you are concerned about how much water usage our records show for your property, you can request a review of our records. Either call SSJID at (209) 249-4675 or go online to www.ssjid.com and on the home page, under Drought Information, you will find an application for assistance with this service. Click on the link and fill out the "Application for Consumption Review," and our staff will call you within two business days to schedule an appointment to go over your water consumption history. Our staff may also be able to offer helpful suggestions for ways you may adjust your irrigation practices in order to get through this difficult season.

Use SSJID's Website for Drought Updates and Online Water Usage Data

We strongly encourage you to go to SSJID's website and sign up for an online account, where you will be able to monitor your water usage, pay your bill online (not required to view usage) and see your water usage in terms of inches applied, as well as acre-feet used. The data will be updated immediately after each irrigation, so it will be a good tool for you to keep close track of your water usage throughout the season. To sign up for online services, go to the District Services tab, then Billing and Customer Services. Here you will find the "Pay your bill online" button. Click and follow the instructions to create your account. If you have questions regarding this service, please contact Robin Giuntoli at (209) 249-4610. In addition, our website's home page, under Drought Information, will be updated if conditions change, new program options are added, and for the latest information from SSJID regarding the drought and how it will affect our growers.

Also, for measurement accuracy for those using drip, sprinkler or micro systems, we strongly recommend that you call your Division Manager/Ditchtender with the start and stop times of your water deliveries if you shut off earlier than your water order, so that you will not be billed for water you did not use.

Allotment Transfer Program

The District's Allotment Transfer Program will be essential for many growers to achieve a successful crop this year. The "Water Allotment Transfer Application" is available online as well as at our Main Office, 11011 E. Highway 120 in Manteca. The Water Allotment Transfer rules are also on our website and available at the office. There are several important things to know about the Allotment Transfer Program. The application is required before the process can begin and signatures of both parties are required. Where the land is rented, both the owner and the tenant must sign. You may transfer between your own properties and between those of other growers, as long as there is a connection to the SSJID distribution system.

In addition, with only a few exceptions, the quantity of allotment available to transfer cannot exceed the quantity of water that was used on the source parcels during the preceding season (i.e.—the amount may be less than 36"). Under no conditions can more than 36" from one parcel be transferred. For more details regarding transfers and exceptions, please refer to the official rules on the application form or call our office at (209) 249-4675.

New Program Allows for Allotment Master Accounts

On March 25, the Board of Directors approved a plan to give irrigators more flexibility in managing their 36" allotment this year. The program will allow the grouping of land parcels that are under common management into a single "allotment master account". All the parcels in an allotment master account will be treated as if they were all a single parcel for monitoring use of the 36" allotment. Individual parcels within the master account can use more or less than 36" as long as the master account group as a whole uses no more than 36". For example, if one 10-acre parcel uses 18", another 10-acre parcel in the same master account can use 54" because in combination they are using only 36".

Presently, irrigators who own more than one parcel receive just one bill listing all the parcels they own. Also, those who farm a combination of owned and leased land can have all their leased and owned parcels grouped onto a single bill if they have completed a "Landowner-Tenant Agreement" with the District. To begin with, these same parcel groups will be used for pooling allotments into a master account. This is the default grouping method for allotment master accounts.

Other parcels that are not in the default grouping can be added to an allotment master account. The only requirement is that all the parcels in a master account must be under common management. The common manager could be the owner of some parcels in the master account, a tenant on other parcels, and a "manager" on others. Adding parcels to an allotment master account does not necessarily change which parcels appear on a particular bill, unless the farmers and landowners involved desire that.

In order to add parcels under common management to a master account, we will need a "Master Account Agreement" signed by the property owner and the tenant or manager. The form for the "Master Account Agreement" can be found on the SSJID website home page under the Drought Update banner and is also available at our Main Office. **Our office will accept faxed or emailed agreements, as long as they include an attached PDF with the required signatures. Contact Julie Vrieling at (209) 249-4675, fax (209) 249-4694.** Allotment master accounts will reduce the number of allotment transfers that are needed, and they will be easier for both district personnel and irrigators to manage.

State Water Resources Control Board to Consider Temporary Urgency Change Petition for the Stanislaus as 2015 Goes on Record as the Worst Drought in River's Recorded History

Lake Tulloch is downstream of New Melones Reservoir. It is jointly owned and operated by Oakdale Irrigation District and SSJID as part of the Tri-Dam Project. The two districts' senior water rights usually allow the constituents they serve to have a reliable high quality source of water for irrigation and domestic uses. However, the snow survey for April 1 shows the Stanislaus River watershed at just 4% of normal, the lowest measurement ever recorded.

The two districts have been in negotiations with the federal Bureau of Reclamation (which operates New Melones Reservoir), the National Marine Fisheries Service and the State Water Resources Control Board (SWRCB), urging the approval of a Temporary Urgency Change Petition to better balance the needs of fish and farmers, domestic users, recreational uses, power generation and carryover storage during this worsening drought. Approval of the petition would provide for springtime "pulse flows" for steelhead and salmon on the Stanislaus, base flows for the fish in the river through December, and adequate supplies of water for each district, given serious conservation measures both districts are taking. The hope is that by September 30, at the end of the irrigation season, New Melones will have enough water to meet flows for spawning salmon through December 31. The plan would also help the districts to keep Lake Tulloch at normal operational levels through September. While the districts will continue to press forward with every strategy possible to help

our communities get through this year, **we encourage everyone with an interest in the river to show their support by contacting the SWRCB at info@waterboards.ca.gov, and asking for approval of the petition immediately. Your action is needed!**

The Tri-Dam Project has its own website, www.tridamproject.com, and will be posting weekly updates each Friday. It is important that all interested persons check this website regularly as Tri-Dam will post updates should conditions change, and a drawdown at Lake Tulloch below scheduled operating levels becomes necessary.

Board to Update Policy to Discourage Water Theft

While SSJID already has a Policy to Discourage Unlawful Use of District Water, during this extreme drought the Board of Directors plans to update the policy to ensure that the limited water supply we have is protected for each of our growers. Information regarding the updated policy will be provided as soon as Board action is taken.

EMERGENCY DROUGHT BULLETIN 3 – APRIL 27, 2015



EMERGENCY DROUGHT BULLETIN #3

April 27, 2015

2015 Program for Transfers of Private Water Using District Facilities

South San Joaquin Irrigation District is now offering a program that allows use of district facilities to transfer water from private wells during the 2015 irrigation season. The program exchanges private water for district water so the private water can be used to increase the supply of any parcel in the district that is connected to the irrigation distribution system and at any time after the private water has been pumped.

The program has the following provisions and requirements. Those interested in using this program need to fill out and sign an agreement with the district. The agreement form is available at the Main Office and on the SSJID website (www.ssjid.com). The agreement is between SSJID, the well operator, and the owner, tenant, or contract manager of the receiving parcel. Questions regarding this program? Call Julie Vrieling at 209-249-4675 or email her at jvrieling@ssjid.com.

1. The owner or operator of a private well may pump well water to be used at the same location or a different location, into a district conveyance facility.
2. The quantity of water pumped will be added to the drought allotment for the receiving parcels.
3. Pumping into SSJID facilities can only occur when and where the division manager/ditchtender (DM/DT) can make use of the water, and the DM/DT must approve the pumping schedule.
4. The pump must have a meter that can be used to determine how much water is pumped.
5. After each pumping event, the DM/DT will report to the SSJID engineering department the quantity of water pumped.
6. The receiving parcels can use the additional drought allotment during regularly scheduled irrigation deliveries any time after the water private water has been pumped into district facilities, and before the end of the 2015 irrigation season.
7. SSJID will bill the ordinary volumetric rate of \$3 per acre-foot for all water delivered under this program in order to avoid modifying billing software to distinguish between delivery of private well water or district water.
8. If any parcel has unused drought allotment at the end of the season it is lost and cannot be carried over to a future season.
9. An agreement to transfer private water designates the parcels which are to get the water, clarifies who is responsible for any damages resulting from this activity, gives the DM/DT permission and access to shut down the pump if necessary, and describes pump capacity.

Intentionally Left Blank

EMERGENCY DROUGHT BULLETIN 4 – MAY 8, 2015



Urgent Drought Bulletin—May 8, 2015

SSJID Updates its Policy for Unlawful Use of District Water

While South San Joaquin Irrigation District (SSJID) has had a long standing "Policy to Discourage Unlawful Use of District Water," during this extreme drought the Board of Directors has updated the policy to ensure that the limited water supply we have is protected for each of our growers.

The policy approved in 2014 provides for a written warning after the first violation, loss of one irrigation for the second violation and loss of irrigation for the remainder of the season thereafter.

The policy approved in 2015 also enables the District to disable or remove facilities used by the grower for the third violation of the policy in all year types. In allotment years, the policy also allows the District to disable or remove the facilities if the grower violates the policy just two times, if both occur after the grower's allotment expires. The policy has also been amended to provide that the District will provide written notice before it removes the facilities.

SSJID POLICY TO DISCOURAGE UNLAWFUL USE OF DISTRICT WATER
AMENDING THE May 20, 1919 RULES AND REGULATIONS
Governing the Distribution of Water in the South San Joaquin Irrigation District
Adopted by the Board of Directors on June 10, 2014
Amended April 13, 2015 and April 28, 2015

1. District's existing Rules and Regulations for distribution of water prohibit taking water out of turn: No. 9 – Using Water Out of Turn: any person who uses water out of his turn and without the permission of his ditchtender forfeits his right to water at the next regular irrigation and is also subject to criminal prosecution.

2. Violation of Rule No. 9 is subject to criminal prosecution: **Penal Code § 498. Theft of utility services**

(a) The following definitions govern the construction of this section:

- (1) "Person" means any individual, or any partnership, firm, association, corporation, limited liability company, or other legal entity.
- (2) "Utility" means any electrical, gas, or water corporation as those terms are defined in the Public Utilities Code, and electrical, gas, or water systems operated by any political subdivision.
- (3) "Customer" means the person in whose name utility service is provided.
- (4) "Utility service" means the provision of electricity, gas, water, or any other service provided by the utility for compensation.

(b) Any person who, with intent to obtain for himself or herself utility services without paying the full lawful charge therefor, or with intent to enable another person to do so, or with intent to deprive any utility of any part of the full lawful charge for utility services it provides, commits, authorizes, solicits, aids, or abets any of the following shall be guilty of a misdemeanor:

- (1) Diverts or causes to be diverted utility services, by any means.
- (2) Prevents any utility meter, or other device used in determining the charge for utility services, from accurately performing its measuring function by tampering or by any other means.
- (3) Tampers with any property owned by or used by the utility to provide utility services.
- (4) Makes or causes to be made any connection with or reconnection with property owned or used by the utility to provide utility services without the authorization or consent of the utility.
- (5) Uses or receives the direct benefit of all or a portion of utility services with knowledge or reason to believe that the diversion, tampering, or unauthorized connection existed at the time of that use, or that the use or receipt was otherwise without the authorization or consent of the utility.

3. **The violation of Rule No. 9 by a customer or any other unauthorized removal of water from the District's facilities is prohibited. As used in this Policy, a customer is a person who is charged by the District for irrigation water service on the subject land. A person who is charged a groundwater recharge fee is not considered a customer as to land which is subject to an irrigation service abandonment agreement, but is subject to Section 7.**

4. **Provisions applicable to customers for violations of Section 3 in all years except when a water allotment is in effect:**

(a) The customer will be given a warning for the first violation. Written notice will also be provided to the parcel owner, if different than the violator, in accordance with the County Assessor's records. The warning will include a billing for the charges described in Section 6A.

(b) For the second violation in the same irrigation season, whether or not occurring on the same parcel as the first violation in a particular irrigation season:

- (1) The customer will be subject to the charges described in Section 6A.
- (2) The customer will forfeit the right to water for one irrigation on the parcel or parcels which are the subject of the violations, and on all parcels served by the District that are owned by the violator.

(c) For the third violation in the same irrigation season, whether or not occurring on the same parcel as the previous violations:

- (1) The customer will be subject to the charges described in Section 6A.
- (2) The customer will forfeit the right to District water for the rest of the irrigation season on the parcels which are the subject of the violations and on all parcels served by the District that are owned by the violator.

(d) After the first warning, violations of Section 3 may be referred for criminal prosecution.

5. Provisions applicable to customers for violations of Section 3 in years when a water allotment is in effect:

- (a) This Section 5 is applicable to years when the District's Board of Directors adopts a specific allotment of the quantity of water that will be made available to customers eligible for District irrigation service and to a customer subject to an allotment pursuant to section 5E below.
- (b) For the first violation in a particular irrigation season:
- (1) The customer will be given a warning. Written notice will also be provided to the parcel owner, if different than the violator, in accordance with the County Assessor's records. The warning will include a billing for the charges described in Section 6A.
 - (2) The quantity of water reasonably determined by the District to have been used by the customer will be deducted from the customer's annual water allotment for the year of the violation.
- (c) For the second violation in the same irrigation season, whether or not occurring on the same parcel as the first violation:
- (1) The quantity of water reasonably determined by the District to have been used by the customer will be deducted from the customer's annual water allotment for the year of the violation.
 - (2) The customer will be subject to the charges described in Section 6A.
 - (3) The customer will forfeit the right to water for one irrigation on the parcel or parcels which are the subject of the violations, and on all parcels served by the District that are owned by the violator.
 - (4) If two violations are committed after the water allotment has expired, the customer is also subject to the provisions of Section 6B.
- (d) For the third violation in the same irrigation season, whether or not occurring on the same parcel as the previous violations:
- (1) The quantity of water reasonably determined by the District to have been used by the customer will be deducted from the customer's annual water allotment for the year of the violation.
 - (2) The customer will be subject to the charges described in Section 6A.
 - (3) The customer will forfeit the right to District water for the rest of the irrigation season on the parcels which are the subject of the violations and on all parcels served by the District that are owned by the violator.
- (e) For each violation that occurs after the customer's annual water allotment for the year has been exhausted, the quantity of water reasonably determined by the District to have been used by the customer will be charged against the customer's allotment for the next irrigation season. If an allotment is not generally imposed in the next irrigation season, the customer will be again subject to an allotment in the next irrigation season, and the next season's allotment will be the same as the allotment of the season in which the violation was committed, minus the water taken in excess of the allotment during the year of the violation.
- (f) After the first warning, violations of Section 3 may be referred for criminal prosecution.

6. Provisions applicable to all customer violations of Section 3:

- (a) The violator is subject to a water charge at the rate of \$75 per acre-foot, which is the District's cost of service in 2014, for the quantity of water reasonably determined by the District to have been used, plus the amount necessary to reimburse the District for its costs to remove irrigation facilities used in violation of this Policy, for its costs to repair District facilities damaged in violation of this Policy, and for its costs for investigation and enforcement.
- (b) The District may disable or remove the facilities connected to or installed on the District's facilities that were used in violation of this Policy as follows:
- (1) In all years, when a customer commits three violations in the same irrigation season, whether or not occurring on the same parcel as the previous violations or, in years when a water allotment is in effect, when a customer commits two violations after the customer's water allotment has expired in the same irrigation season, if sooner.
 - (2) After the irrigation season has ended, the customer must replace the facilities in accordance with the District's policies and standards then in effect at the customer's expense before the land will be eligible to receive District water service in accordance with the District's policies.
 - (3) Written notice will be provided to the violator before the facilities are removed. Written notice will also be provided to the parcel owner, if different than the violator, in accordance with the County Assessor's records.

7. Provisions applicable to noncustomers for unauthorized removal of water from the District's facilities:

- (a) This Section 7 is applicable to a violator who is not a customer of the District.
- (b) For the first violation in a particular irrigation season:
- (1) The violator will be given a written warning.
 - (2) The violator will be subject to the charges described in Section 6A.
- (c) On a second offense, in the same irrigation season:
- (1) The District may disable or remove any facilities connected to or installed on the District's facilities that were used to irrigate the subject land. Written notice will be provided to the violator before the facilities are removed. Written notice will also be provided to the parcel owner, if different than the violator, in accordance with the County Assessor's records.
 - (2) The violator will be subject to the charges described in Section 6A.
 - (3) The violation may be referred for criminal prosecution.

8. This policy amends the District's Rules and Regulations for distribution of water originally adopted May 20, 1919.

EMERGENCY DROUGHT BULLETIN 5 – JUNE 8, 2015



EMERGENCY DROUGHT BULLETIN #5

June 8, 2015

Important Changes to SSJID's Allotment Transfer Program

Deadline for Allotment Transfers Eliminated

At South San Joaquin Irrigation District's board meeting on May 20, the board decided that the previous deadline of June 15 for applications for allotment transfers is unnecessary and will be eliminated. Therefore, SSJID growers can apply for an allotment transfer anytime during the 2015 irrigation season, allowing for more time to plan mid and late season use of water.

The "Water Allotment Transfer Application" is available online (www.ssjid.com) as well as at our Main Office, 11011 E. Highway 120 in Manteca. The Water Allotment Transfer rules are also on our website and available at the office. There are several important things to know about the Allotment Transfer Program. The application is required before the process can begin and signatures of all parties are required. Where the land is rented, both the owner and the tenant must sign. You may transfer between your own properties and between those of other growers, as long as there is a connection to the SSJID distribution system.

In addition, with only a few exceptions, the quantity of allotment available to transfer cannot exceed the quantity of water that was used on the source parcels during the preceding season (i.e.—the amount may be less than 36"). Under no conditions can more than 36" from one parcel be transferred. For more details regarding transfers and exceptions, please refer to the official rules on the application form or call our office at (209) 249-4675.

Allotment Transfer Agreements Can be Rescinded Subject to Conditions and Requirements

If you have been considering applying for an allotment transfer agreement but are concerned that SSJID's board may need to reduce the allotment of 36" per parcel due to worsening drought conditions, you may now rescind a transfer agreement under the following conditions and requirements:

1. As a preceding condition, the general drought allotment has been reduced by the Board of Directors.
2. All parties to the transfer must agree to unwind it by signing a transfer rescission agreement.

3. The amount of allotment recovered from each destination parcel is the amount originally transferred to the destination parcel or if less, the amount of allotment remaining unused on the destination parcel.
4. The amount of allotment restored to the source parcels is the amount recovered from the destination parcels.
5. If there is more than one source parcel, the amount of allotment restored is distributed among the source parcels in proportion to the original transfer.
6. Once rescinded, a new allotment transfer agreement can be made.

As always, feel free to call our office at (209) 249-4675 and Julie Vrieling, our water conservation coordinator, will be happy to assist you with any of our drought provision programs and/or provide you with information regarding your 2015 irrigation season water usage.

Recap of SSJID's 2015 Drought Year Programs

The following programs have been established to assist our growers with challenging drought conditions during the 2015 irrigation season.

- ⇒ Approval of a program to transfer water from a private well to any location in the District, regardless of which lateral they use, or whether they are upstream or downstream from the well.
- ⇒ Adoption of a 36" per parcel drought allotment, which limits irrigation water deliveries in order to make our limited supply last through this season, and possibly augment next year's supply.
- ⇒ Establishment of a Master Account for allotments that enables growers to combine the water allotments of all the fields they farm and decide where to use the water.
- ⇒ Establishment of a program for transfer of allotments among parcels so farmers can increase their allotment by making a transfer agreement with another farmer.
- ⇒ Daily updating growers' water use history on the District's website once an online account has been established.
- ⇒ Provision of a consumption review service to address concerns about the accuracy of the record of the growers' consumption.

SSJID General Manager to Retire In October

When South San Joaquin Irrigation District General Manager Jeff Shields announced on April 13, 2015, that he would retire sometime before the end of the year, the SSJID Board of Directors expressed a desire to implement a succession plan that would assure a smooth transition as the District moves forward with its business.



"Jeff has been a tremendous asset to the District for the past 11 years. He will continue to have the full confidence and support of the board in his duties until such time that we develop a succession plan that will include finding his replacement," said Robert Holmes, SSJID board president.

"When my contract came up for renewal this year, I asked the board to renew it on a month to month basis, with the intent to retire before December 31, 2015," said Shields. "I am 67 years old and nearing retirement, but I want to work with the board and staff towards an orderly transition to new management. I am committed to continuing to support the efforts of SSJID as we work through this serious drought and water rights issues, and to advance the District's efforts to provide retail electric service to our community."

Shields has been with SSJID since June 2004 and has over 36 years of public agency and private sector executive management experience. He was appointed general manager in 2007, after serving as the District's utility systems director. Under his tenure with the District, SSJID built and is now successfully operating a solar farm that provides power for the Nick C. DeGroot Water Treatment Plant. The plant provides drinking water to Manteca, Lathrop and Tracy; the move to solar power has allowed the cities to keep their cost of wholesale water affordable.

South San Joaquin Irrigation District also built an award winning, state-of-the-art pressurized water delivery system in the Ripon area under Shields' direction. The "Division 9 Irrigation Enhancement Project" has received numerous state, national and international awards and recognition. Currently, Shields is overseeing a study to determine the feasibility of pressurizing all, or additional divisions, of the District. He is also managing the irrigation district through what is shaping up to be the most difficult water delivery year in SSJID's history, as California experiences its fourth year of a serious drought.

Among Shields' many notable accomplishments was guiding the District through the San Joaquin County Local Agency Formation Commission (LAFCo) process as SSJID sought approval to become the retail electric provider in its service territory. SSJID won this approval late last year, and has now completed all of the necessary LAFCo requirements. SSJID's plan will eventually bring a 15% rate discount to all current PG&E customers in Escalon, Manteca and Ripon, along with local control by an elected board of directors.

Shields' experience outside of SSJID includes 10 years as general manager of Emerald People's Utility District in Oregon, and also seven years as general manager of Trinity PUD in Northern California.

He is credited with leading several agencies into the retail power business in order to reduce electricity costs for consumers and key industries. He also has experience in land use planning and environmental compliance consulting, providing expert witness services by testifying before state and federal regulatory and governing authorities, securing transmission for renewable energy projects and managing all aspects of utilities.

"I love this community and plan to stay in Ripon and continue to be actively involved in water and energy issues," said Shields. He will continue to serve on the board of The Utility Reform Network (TURN) as well as the board of the Local Energy Aggregation Network. In addition, he will continue as a board member for Give Every Child a Chance (GECAC) and as member of the Manteca Rotary Club.

SSJID Says Farewell to Customer Service Representative Luz Juarez

SSJID is preparing to say "Farewell" to Luz Juarez, our customer service representative who has been with the District for 37 years. Luz has been a key team member at SSJID, as she is the first person who greets everyone who visits our office, handles customer service for our growers and interfaces with outside organizations that seek information regarding property within the District. She is also well-known in the Manteca and Lathrop community through her work for her church and other volunteer efforts. Luz will be retiring from the District on June 30, which will be a bittersweet day for her coworkers who have grown to love and appreciate her for the kind, outgoing and helpful employee that she is. Whether it be handling calls from title companies, questions from customers or calming the occasional upset grower, Luz navigates every situation with grace and professionalism. Her knowledge of the District's history during her tenure is a treasure that will be sorely missed.



Luz is looking forward to having more time to spend with her family, to travel, and to relax, as she settles into a new routine that will no longer include her excellent attendance as an SSJID employee. We hope she will come by for an occasional visit as we look forward to hearing all about the joys of retirement from this most valued employee. Please join us in wishing Luz a wonderful retirement!

As SSJID's Finance and Administration Department anticipates several additional future employee retirements, there are two new faces that recently joined our team. Leah Codoni and Maria Gikas, both accounting technicians, will be learning each of the functions of the department and are looking forward to serving our customers in the same friendly and helpful manner as you are accustomed to. We welcome both Leah and Maria to the SSJID family.

EMERGENCY DROUGHT BULLETIN 6 – JULY 8, 2015

Emergency Drought Bulletin

July 8, 2015

SSJID is adding a new informational program for growers who need additional water, and growers who want to make water available through a transfer. This program will be facilitated through the District's website: www.ssjid.com. There will be a link under the Drought section on the home page that will list growers who are interested in accessing additional water from a list of growers who have water available (either from their allotment or from their private well water). The link will say: **Grower Water Exchange Information**. If you wish to take advantage of listing your name and contact information through this program, you will agree that your participation is completely voluntary, and that the District will simply be making the names and contact information available, but will not be involved with the actual contact between growers who want to list their names on this website page. However, depending on how the exchange is to be conducted, growers involved will have to fill out the required applications, which could be an **Allotment Transfer Application** and/or an **Agreement for Transfer of Water Through District Facilities**.

If you would like to participate in this informational program and list your name on our website, please contact Julie Vrieling at (209)249-4675 or jvrieling@ssjid.com for assistance. Please let Julie know whether you have a need for additional water OR if you have additional water available. We hope that this program will be another tool that the District can provide to help you get through this difficult Drought Emergency irrigation season.

Intentionally Left Blank

APPENDIX E. EASTERN SAN JOAQUIN GROUNDWATER SUBBASIN GROUNDWATER SUSTAINABILITY PLAN

Intentionally Left Blank

Eastern San Joaquin Groundwater Subbasin

2024 Groundwater Sustainability Plan Amendment: Agency Information, Plan Area, and Communication

Prepared by:



November 2024

The *Eastern San Joaquin Groundwater Subbasin Groundwater Sustainability Plan* is available online at: <http://www.esjgroundwater.org/>.

APPENDIX F. DWR WATER BUDGET REPORTING TABLES

Intentionally Left Blank

This appendix provides the water year water budget tables required by DWR as part of the 2020 AWMP submittal package.

As described in Sections 4 and 5 of the 2020 AWMP, SSJID has historically calculated and presented a calendar year or an irrigation season water budget for agricultural water management planning efforts. Accounting for water during the calendar year provides a clearer depiction of agricultural and irrigation practices by growers, and the District’s operations that support those practices over a single irrigation season.

Water year summaries have historically not been reported because irrigation seasons in SSJID typically begin in March and may extend into October or November, straddling two water years (defined as October 1 – September 30). Water year reporting thus cuts irrigation seasons into multiple reporting years.

However, to fulfill the updated AWMP requirements pursuant to AB 1668, SSJID has calculated a boundary water balance on a water year basis (October 1 – September 30) for the SSJID agricultural service area.

The water year water budget tables for SSJID are provided below in Table F-1 (Inflows) and Table F-2 (Outflows). Additional details regarding the required inflow and outflow components are given in Tables F-3 and F-4, respectively. These detailed tables describe all boundary flow paths in the SSJID water budget that comprise the inflow and outflow components required by DWR.

Because the SSJID irrigation season straddles two water years nearly every year, all flow paths differ slightly between the calendar year water budgets reported in Section 5 of the AWMP and in the tables below.

Intentionally Left Blank

Table F-1. Water Budget Inflows (DWR Table V-1).

Inflow Components ¹	AWMP Location for Supporting Calculations	Volume Quantification Method ²	Percent Uncertainty ²	Uncertainty Quantification Method ²	Volume (af per water year)				
					2020	2021	2022	2023	2024
Effective Precipitation ³	5.3	Modeled	10%	Modeled	21,622	12,946	21,695	36,241	26,780
Water Supplier Surface Water Diversions	5.3	Measured	5%	Measured	249,802	218,383	223,999	193,421	225,476
Water Supplier Groundwater Pumping	5.3	Measured	20%	Estimated	4,661	5,317	6,414	4,208	2,898
Private Pumping	5.3	Estimated	50%	Estimated	60,978	81,446	76,507	61,007	60,386
Other - OID Spills to Main Canal	5.3	Measured / Estimated	50%	Estimated	3,439	3,061	3,061	5,111	12,608
Other - Ordered Spillage	5.3	Measured	5%	Measured	0	0	0	0	0
Other - Tributary Inflow and Stormwater Runoff	5.3	Estimated	40%	Estimated	5,382	2,694	6,134	15,506	7,549
Other - Additional Precipitation (Total Precipitation minus Effective Precipitation) ³	5.3	Measured	30%	Estimated	16,187	5,866	19,793	58,028	23,471
Total Inflows⁴					362,070	329,710	357,600	373,520	359,170

¹ Details about all SSJID water budget flow paths included in each Inflow Component are provided in Table F-3.

² For required Inflow Components that include multiple SSJID water budget flow paths, the quantification methods and uncertainty represent the typical methods and uncertainties among all flow paths represented. Details on each SSJID water budget flow path are provided in Table F-3.

³ Effective precipitation is equivalent to ET of Precipitation, which is accounted as an outflow from the SSJID water budget. To account for all inflows, the additional precipitation (total precipitation minus effective precipitation) has also been added as an “Other” Inflow Component.

⁴ Total volumes rounded to 10 af.

Table F-2. Water Budget Outflows (DWR Table V-2).

Outflow Components ¹	AWMP Location for Supporting Calculations	Volume Quantification Method ²	Percent Uncertainty ²	Uncertainty Quantification Method ²	Volume (af per water year)				
					2020	2021	2022	2023	2024
Evapotranspiration (Crop Consumptive Use) ³	5.3	Modeled	10%	Modeled	166,707	168,396	166,982	158,785	157,493
Surface Outflows	5.3	Measured / Calculated	30%	Estimated	39,293	36,911	48,049	58,484	66,954
Deep Percolation ⁴	5.3	Calculated	50%	Estimated	134,044	129,238	143,584	134,649	113,141
Other - Evaporation	5.3	Calculated	90%	Estimated	10,435	10,733	10,921	9,975	9,999
Other - Change in Root Zone Storage	5.3	Modeled	30%	Modeled	567	203	446	4,983	505
Other - Change in Reservoir Storage	5.3	Calculated	50%	Estimated	11,026	-15,767	-12,382	6,646	11,076
Total Outflows⁵					362,070	329,710	357,600	373,520	359,170

¹ Details about all SSJID water budget flow paths included in each Outflow Component are provided in Table F-4.

² For required Outflow Components that include multiple SSJID water budget flow paths, the quantification methods and uncertainty represent the typical methods and uncertainties among all flow paths represented. Details on each SSJID water budget flow path are provided in Table F-4.

³ Evapotranspiration includes ET of Applied Water (crop consumptive use of applied water) and ET of Precipitation (equivalent to effective precipitation, an inflow component). Each component is shown in Table F-4.

⁴ Deep percolation includes Deep Percolation of Applied Water from Irrigated Lands (IL Deep Percolation_{aw}), Deep Percolation of Precipitation from Irrigated Lands (IL Deep Percolation_{precip}), and Seepage from SSJID canals, laterals, drains, and Woodward Reservoir. Each component is shown in Table F-4.

⁵ Total volumes rounded to 10 af.

Table F-3. Water Budget Inflows - Detail.

Inflow Components	SSJID Water Budget Flow Paths	AWMP Location for Supporting Calculations	Volume Quantification Method	Percent Uncertainty	Uncertainty Quantification Method	Volume (af per water year)				
						2019	2020	2021	2022	2023
Effective Precipitation	ET of Precipitation (IL ET _{precip}) ¹	5.3	Modeled	10%	Modeled	21,622	12,946	21,695	36,241	26,780
<i>Water Supplier Inflows</i>										
Surface Inflow	Deliveries from Joint Supply Canal	5.3	Measured	5%	Measured	249,802	218,383	223,999	193,421	225,476
Groundwater Pumping	District Pumping	5.3	Measured	20%	Estimated	4,661	5,317	5,382	3,431	2,898
	Pumping for Groundwater Transfer	5.3	Measured	5%	Measured	0	0	1,032	778	0
<i>Private Inflows</i>										
Groundwater Pumping	Private Pumping	5.3	Estimated	50%	Estimated	60,978	81,446	76,507	61,007	60,386
<i>Other Inflows</i>										
	OID Spills to Main Canal	5.3	Measured / Estimated	50%	Estimated	3,439	3,061	3,061	5,111	12,608
	Ordered Spillage	5.3	Measured	5%	Measured	0	0	0	0	0
	Tributary Inflow	5.3	Estimated	50%	Estimated	3,476	1,734	3,968	10,521	4,947
	Stormwater Runoff	5.3	Modeled	35%	Modeled	1,906	961	2,166	4,985	2,602
	Total Precipitation ¹ , less Effective Precipitation	5.3	Measured	30%	Estimated	16,187	5,866	19,793	58,028	23,471
	Total Inflows¹					362,070	329,710	357,600	373,520	359,170

¹ Effective precipitation is equivalent to ET of Precipitation, which is accounted as an outflow from the SSJID water budget. To account for all inflows, the additional precipitation (total precipitation minus effective precipitation) has also been added as an “Other” Inflow Component. Total precipitation includes the SSJID water budget flow paths: MDC Precip, IL Precip, and Reservoir Precip.

² Total volumes rounded to 10 af.

Table F-4. Water Budget Outflows – Detail

Outflow Components	SSJID Water Budget Flow Paths	AWMP Location for Supporting Calculations	Volume Quantification Method	Percent Uncertainty	Uncertainty Quantification Method	Volume (af per water year)				
						2020	2021	2022	2023	2024
<i>Evapotranspiration (Crop Consumptive Use)</i>										
	ET of Applied Water (IL ET _{aw})	5.3	Modeled	10%	Modeled	145,085	155,450	145,287	122,543	130,713
	ET of Precipitation (IL ET _{precip})	5.3	Modeled	10%	Modeled	21,622	12,946	21,695	36,241	26,780
<i>Surface Outflows</i>										
	District Outflow	5.3	Estimated / Measured	50%	Estimated	13,371	10,907	20,969	32,377	41,873
	U3 Ranch Deliveries	5.3	Measured / Calculated	100%	Estimated	1,851	1,822	2,050	2,010	2,039
	WTP Deliveries	5.3	Measured	5%	Measured	23,804	23,890	23,620	23,079	22,741
	Surface Water Deliveries (to Urban Lands)	5.3	Calculated	25%	Estimated	268	293	379	240	300
	GW Transfer	5.3	Measured	5%	Estimated	0	0	1,032	778	0
	Operational Spillage	5.3	Measured / Calculated	9%	Calculated	0	0	0	0	0
	Ordered Spillage	5.3	Measured	5%	Measured	0	0	0	0	0
<i>Deep Percolation</i>										
	Deep Percolation of Applied Water (IL Deep Percolation _{aw})	5.3	Calculated	66%	Calculated	66,756	64,433	64,437	50,788	53,736
	Deep Percolation of Precipitation (IL Deep Percolation _{precip})	5.3	Modeled	30%	Modeled	14,766	5,202	17,863	50,045	21,607
	Seepage - MSC (MSC Canal Seepage)	5.3	Calculated	50%	Estimated	499	470	472	390	482
	Seepage - MDC (MDC Canal Seepage)	5.3	Calculated	47%	Calculated	29,297	35,816	37,391	9,948	13,090
	Seepage - District Laterals (Lateral Seepage)	5.3	Calculated	50%	Estimated	5,448	5,126	5,130	4,255	5,356
	Net Seepage - Drainage System (Seepage/GW Interception)	5.3	Calculated	100%	Estimated	2,005	2,080	1,796	2,157	2,163
	Seepage - Woodward Reservoir (Reservoir Seepage)	5.3	Calculated	50%	Estimated	15,273	16,111	16,494	17,066	16,706
<i>Other</i>										
	Evaporation - District Laterals (DL Evap)	5.3	Calculated	30%	Estimated	746	753	758	616	694
	Evaporation - MSC (MSC Evap)	5.3	Calculated	30%	Estimated	81	82	82	67	75
	Evaporation - MDC (MDC Evap)	5.3	Calculated	30%	Estimated	548	553	557	453	510
	Evaporation - Drainage System (DS Evap)	5.3	Calculated	30%	Estimated	378	390	381	356	357
	Evaporation - Woodward Reservoir (Reservoir Evap)	5.3	Calculated	100%	Estimated	8,682	8,956	9,144	8,484	8,364
	Change in Root Zone Storage	5.3	Modeled	30%	Modeled	567	203	446	4,983	505
	Change in Reservoir Storage	5.3	Calculated	50%	Estimated	11,026	-15,767	-12,382	6,646	11,076
	Total Outflows¹					362,070	329,710	357,600	373,520	359,170

¹ Total volumes rounded to 10 af.

APPENDIX G. PUBLIC OUTREACH AND RESOLUTION ADOPTING PLAN

Intentionally Left Blank

SSJID Website Information Regarding 2025 AWMP

The Notice of Public Hearing for the 2025 AWMP was communicated to the public through the SSJID website, www.ssjid.gov.

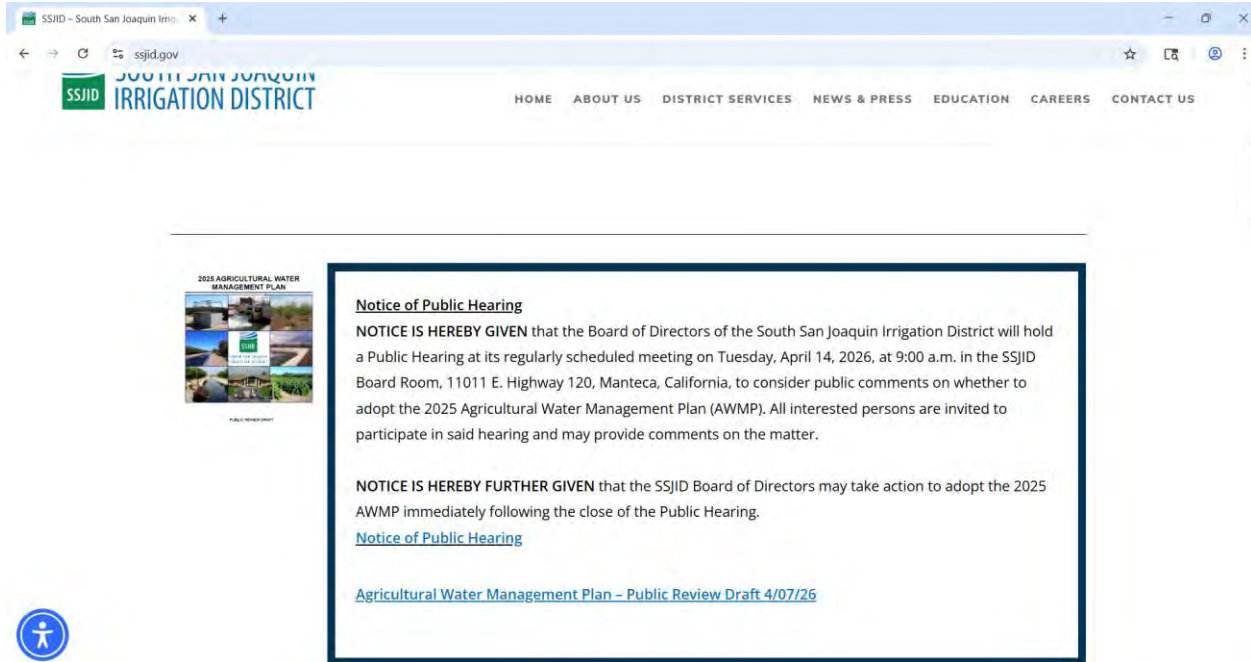

Intentionally Left Blank

Table G-1. SSJID Agricultural Water Management Plan – Outreach/Distribution List

Agency/Entity ¹	Contact / Title / Department	Address	Notice of Intent Letter	Draft Plan, via Website	Adopted Plan, via Website (By Email)	Adopted Plan Submittal (Method)
County of San Joaquin	Ashley Couch, Water Resources Manager, San Joaquin County Public Works	PO Box 1810, Stockton, CA 95201	X	X	X	
County of Stanislaus	Christy McKinnon, Water Resources Manager	Via Email	X	X	X	
City of Escalon	Jaylen French Escalon City Manager	2060 McHenry Avenue, Escalon, CA 95320	X	X	X	
City of Lathrop	Michael King, Lathrop Assistant City Manager	390 Towne Centre Drive, Lathrop, CA 95330	X	X	X	
City of Manteca	George Montross, Manteca Deputy Director of Public Works	1001 W. Center Street, Manteca, CA 95337	X	X	X	
City of Ripon	Kevin Werner Ripon City Administrator	259 N. Wilma Avenue, Ripon, CA 95366	X	X	X	
City of Tracy	Stephanie Reyna-Hiestand, Tracy Utilities Deputy Director	3900 Holly Drive, Tracy, CA 95304	X	X	X	
South San Joaquin GSA	Brandon Nakagawa, Secretary			X	X	
Eastern San Joaquin Groundwater Authority	Julia Berry, Executive Director			X	X	
California Department of Water Resources	Statewide Integrated Water Management, Water Use Efficiency Branch	PO Box 942836, Sacramento, CA 94236-0001		X	X	X (Electronic)
California State Library	Gov't Publication Section	PO Box 942837, Sacramento, CA 94237-0001			X	X (Email)
San Joaquin County Library					X	
LAFCo of San Joaquin County					X	
The Public				X	X	

Sample Notice of Intent Letter to Local Public Agencies



March 24, 2026

Jaylen French
Escalon City Manager
2060 McHenry Avenue
Escalon, CA 95320

Sent Via Email

SUBJECT: NOTICE OF INTENT TO PREPARE AND ADOPT THE SSJID 2025 AGRICULTURAL
WATER MANAGEMENT PLAN

Jaylen
Mr. French:

On behalf of the South San Joaquin Irrigation District (District), I am writing to notify you of the District's intent to prepare and adopt its 2025 Agricultural Water Management Plan (AWMP) as required by State law. The District is preparing a public review draft that will be available on our website by March 31, 2026. The District Board of Directors has set the public hearing date for the adoption of the 2025 AWMP at 9:00 A.M., on Tuesday, April 14, 2026, at a regularly scheduled Board meeting.

The District is required to prepare an updated AWMP every five years for the periods ending in zero and five. Agricultural water suppliers must report their calculated water balances to demonstrate the efficacy of water management practices implemented by agencies and their customers. The AWMP is an opportunity to document the District's efforts to improve the efficiency of its irrigation deliveries. The District is committed to securing our collective water future while maintaining healthy groundwater levels.

For more information about State requirements, please visit the Department of Water Resources (DWR) Agricultural Water Use Efficiency Program website at <https://water.ca.gov/Programs/Water-Use-And-Efficiency/Agricultural-Water-Use-Efficiency>. DWR encourages agencies to seek comment from cities and counties within the area covered by the AWMP. Should you have any questions or concerns as the District moves forward with the preparation and adoption of its AWMP, please feel free to contact me, at (209) 305-8442 or brandon.nakagawa@ssjid.gov.

Sincerely,

A handwritten signature in blue ink that reads "B. Nakagawa".

BRANDON W. NAKAGAWA, P.E.
Water Resources Coordinator

11011 East Highway 120, Manteca CA 95336 - PO Box 747, Ripon, CA 95366 - District Office: (209) 249-4600

SSJID.gov

Public Hearing Notice



MANTECA BULLETIN

P.O. BOX 1958, • 531 E. YOSEMITE AVE., MANTECA, CA 95336-1958 • MAIN 209-249-3500 • FAX - 209-249-3559

SOUTH SAN JOAQUIN IRRIGATION DISTRICT

Classified Insertion Order

MB#03-96/Notice of a Public Hearing to Adopt 2025 AWMP

Contact:	Sales Rep: MB - Liz Mora	Order Date: 3/26/2026
Address: SOUTH SAN JOAQUIN IRRIGATION DISTRICT 1101 E. HIGHWAY 120 MANTECA CA 95336	Phone: 209-249-4600	Order Number: 164244
	Email: ap@ssjid.gov	
		Advertiser No: 25859

Start Date	End Date	No. of Runs	No. of Publications	Description	Classification	Ad Size	Price
3/31/2026	4/7/2026	6	3	MB#03-96/Notice of a Public Hearing to Adopt 2025 AWMP	Public Hearings/Notices	3.9813 Inches	\$200.00
Publications: 209M - Marketplace 209, MB - Manteca Bulletin, MB - Manteca Bulletin Online NOTICE OF A PUBLIC HEARING TO ADOPT THE SOUTH SAN JOAQUIN IRRIGATION DISTRICT 2025 AGRICULTURAL WATER MANAGEMENT PLAN NOTICE IS HEREBY GIVEN that the Board of Directors of the South San Joaquin Irrigation District will hold a Public Hearing at its regularly scheduled meeting on Tuesday, April 14, 2026, at 9:00 a.m. in the SSJID Board Room, 11011 E. Highway 120, Manteca, California, to consider public comments on whether to adopt the 2025 Agricultural Water Management Plan (AWMP). All interested persons are invited to participate in said hearing and may provide comments on the matter. NOTICE IS HEREBY FURTHER GIVEN that the SSJID Board of Directors may take action to adopt the 2025 AWMP immediately following the close of the Public Hearing. A COPY OF THE 2025 AWMP is available on the SSJID website, at www.SSJID.gov. A physical copy may be made available for inspection located at the South San Joaquin Irrigation District Main Office, 11011 E. Highway 120, Manteca, California. Should you have any questions, please contact Brandon Nakagawa, SSJID Water Resources Coordinator, at 209-305-8442 or brandon.nakagawa@ssjid.gov. Publication Dates: 3/31/26 & 4/7/26 MB#03-96							
		Run Count: 6	Publication Count: 3		SubTotal:	\$200.00	
						Total Price:	\$200.00

Authorization To Run Advertisement

Brandon Nakagawa

Printed Name

Bla L

Signature

Adoption Resolution

**SOUTH SAN JOAQUIN IRRIGATION DISTRICT
RESOLUTION NO. 26-11-W**

ADOPTION OF 2025 AGRICULTURAL WATER MANAGEMENT PLAN

WHEREAS, the Agricultural Water Management Planning Act, codified in section 10800 *et seq.* of the California Water Code (“CWC”), requires all agricultural water suppliers greater than 25,000 acres in size to prepare and adopt an Agricultural Water Management Plan (“AWMP” or “Plan”); and

WHEREAS, South San Joaquin Irrigation District (“District”) has prepared a Plan which satisfies the requirements of CWC Section 10826 and the guidance put forth by the Department of Water Resources (“DWR”); and

WHEREAS, an AWMP shall be updated every five years and adopted and submitted in years ending in six and one; and

WHEREAS, on March 24, 2026, the Board of Directors set the public hearing date on whether to adopt the 2025 AWMP for 9:00 a.m. on April 14, 2026 at a regularly scheduled meeting; and

WHEREAS, the District notified the Counties of San Joaquin and Stanislaus and the Cities of Escalon, Lathrop Manteca, Ripon, and Tracy of the intent to prepare the 2025 AWMP and of the opportunity to provide public comment at the public hearing prior to adoption; and

WHEREAS, in accordance with Government Code Section 6066, the District published a legal notice in the Manteca Bulletin on March 31 and April 7, 2026, notifying the public of the availability of the Draft 2025 AWMP on the District’s website and of the time and place for the public hearing; and

WHEREAS, the Board of Directors duly conducted the public hearing at its regular meeting on April 14, 2026; and

WHEREAS, once adopted, the CWC requires that the Plan be submitted to DWR by May 1, 2026.

NOW, THEREFORE BE IT RESOLVED AND ORDERED, by the Board of Directors of the South San Joaquin Irrigation District as follows:

1. The 2025 AWMP is hereby adopted; and
2. Staff is hereby directed to submit the 2025 AWMP to DWR by May 1, 2026 and to file the Plan with other appropriate entities as required by the CWC; and
3. The General Manager is hereby authorized and directed to take appropriate action to implement the 2025 Agricultural Water Management Plan.

PASSED AND ADOPTED on this 14th day of April, 2026, by the following roll call vote:

AYES: HOLBROOK ROOS SPYKSMA WESTSTEYN
NOES: NONE
ABSTAIN: NONE
ABSENT: VAN RYN

ATTEST:

PETER M. RIETKERK, Secretary